



2016 - 2017

Stone Fabrication and Processing Tools





Global experience, Local commitment.

Diamant Boart manufactures a complete range of diamond tools for cutting and processing of natural stone. Our ability to offer tools that customers need is due to our long history of commitment. Since our establishment in 1937, we have constantly strived to develop and provide the latest diamond tool technologies to give customers better solutions and ultimately, increased return on investment.

Developing relationships and maintaining constant contact with our customers all over the world give us valuable knowledge about how tools perform and what is additionally needed. This experience is the basis for the development of new products as well as the ongoing improvements to existing products.

Diamant Boart & Husqvarna

Diamant Boart and Husqvarna form Husqvarna Construction Products, which is the leader of equipment and diamond tools for the construction and stone industries. Together we have technical competence, business experience, market knowledge and resources to further develop the most efficient and innovative diamond tools and equipment available.



Husqvarna[®]



Contents.



Technical Information	6
Cutting Tools	9
Shaping Tools	27
Polishing Tools	39
CNC Tools	61
Service / Specialty Tools	88

We reserve the right to make changes in technology, specifications and pricing without prior notice.

IMPORTANT INFORMATION

Prices effective
September 1, 2015.

TERMS/WARRANTY INFORMATION

Special Note: Availability

The type style of the item number in each specification chart is used to show which sizes and specifications are available. Bold print indicates the item is a stock item. These items are generally available for immediate shipment from stock. Regular print indicates the item may not be in stock. These items may not be available for immediate shipment.

Sales Policy Pricing

All product specifications and prices quoted are subject to change without notice. An additional set-up charge may be applied for special diamond product orders. All prices are in Canadian dollars and NET prices. The minimum order is \$75 net - excluding freight and taxes. Diamant Boart will now accept Visa®, American Express® and Mastercard® for purchase payment.

Taxes

All product sales are subject to applicable taxes.

Freight Terms

All product orders \$500 or more will be ground freight prepaid in Canada. Other orders: FOB shipping point, freight charged from point of shipment.

Past Due Accounts

A service charge of 1.5% per month will be added to all overdue account balances.

Return for Repairs & Replacements

New & Used Product

Contact your area representative or the factory for approval to return merchandise. A customer service representative will issue a Return Goods Authorization (RGA) number that must be marked plainly on the outside of the return package. Note: Any package without a return number will not be accepted at the factory.

A 15% restocking charge will be applied. Non-standard product will not be accepted for return.

Diamond Blade Warranty/Repair Returns

Contact your area representative or the factory for approval to return merchandise and to have a Diamond Blade Repair (DBR) number issued. The DBR number must be marked plainly on the item as well as on the outside of the return package.

SERVICE CENTER

Please call 800-461-9589 to be connected to the Canadian head office.



Diamant Boart Stone Division Facilities in North America

Proud Members of:



Bridge Saw Blades: Bladeshaft/Spindle RPM Chart

Please use the following blade application chart as a general reference guide for best performance when cutting mixed granites and marbles. Spindle RPM can alter blade's cutting characteristics.

Diameter		Granite Soft	Granite Medium	Granite Hard	Marble
mm	Inches	Spindle RPM	Spindle RPM	Spindle RPM	Spindle RPM
300	12	1,900	1,725	1,500	2,300
350	14	1,600	1,500	1,350	2,000
400	16	1,500	1,300	1,200	1,750
450	18	1,300	1,150	1,050	1,550
500	20	1,150	1,050	1,000	1,400
550	22	1,000	950	850	1,275
600	24	950	850	800	1,175
650	26	875	800	725	1,075
700	28	825	750	675	1,000
750	30	775	675	625	950
800	32	725	650	600	875
900	36	625	575	525	775
1000	40	575	525	475	700
1200	48	475	425	400	600

Water Flow and Volume

Water flow and volume are very important to the performance of a blade. Never run a diamond blade dry unless it is designed to be run dry. However, changing the amount of water can alter the blade's cutting characteristics.

Core Bits

Below are general RPMs for core bits running at optimum performance levels. Levels may vary depending on the manufacturer. It is important to note that running core bits at faster RPMs isn't always necessary. When diamond tools exceed their recommended speed, the diamonds tend to glaze over and the tool fails to work properly. To fix this, core bits can often be redressed using a conditioning stick. The same rule is applied if using water. Excessive amounts of water can cause the tool to work at a less-than optimal level.

- 1/4" - 3/8" diameter - 3,500 RPM
- 1/2" - 3/4" diameter - 2,000 RPM
- 1" - 1-1/2" diameter - 1,200 RPM
- 1-3/4" - 3" diameter - 900 RPM
- 4" - 6" diameter - 400 RPM

Polishing Pads

Below are common RPM guidelines for optimum performance levels of various polishing pads. In general, when pads are used on grinders operating between 9,000 – 15,000 RPMs, the pads will glaze and the optimum polish will not occur.

Type	Optimum RPMs
Granite Wet	4,500 RPMs
Granite Dry	3,000 RPMs
Marble	2,000 – 2,500 RPMs (vary due to manufacturer)



CUTTING TOOLS



BRIDGE SAW BLADES	10
RODDING BLADES	13
SMALL DIAMETER BLADES	14
SPECIALTY BLADES/WHEELS	18
ZERO TOLERANCE/SINK WHEELS	19
CORE/ NON-CORING BITS	22
TILE BLADES	24

360 PT Blade. ■ ■ 💧 ▨

- Sandwich segment with silent core to reduce noise level
- 20 mm high segments with Patterned Diamond Technology, which equally distributes diamonds in layers for consistent, fast cuts

DIAMETER INCHES (MM)	METRIC SEGMENT DIMENSION L X W X H	NUMBER OF SEGMENTS	ARBOR MM	ITEM NO.	NET PRICE
12 (300)	40 x 3.2 x 20	24	60/50	542867067	\$277.00
14 (350)		26		542865345	\$308.00
16 (400)		28		542865346	\$329.00
18 (450)	40 x 3.4 x 20	33		542865347	\$370.00
20 (500)		37		542867335	\$514.00



RAMBO™ 26 Blade. ■ ■ 💧 ▨

- 26 mm high segments with additional diamond concentration in the slanted segments
- Patterned Diamond Technology equally distributes diamonds in layers for consistent, fast cuts

DIAMETER INCHES (MM)	METRIC SEGMENT DIMENSION L X W X H	NUMBER OF SEGMENTS	ARBOR MM	ITEM NO.	NET PRICE
12 (300)	40 x 3.2 x 26	19	60/50	542867068	\$277.00
14 (350)		23		542867032	\$318.00
16 (400)		26		542867033	\$339.00
18 (450)		28		542867034	\$401.00



XOC (Shock) Blade. ■ ■ 💧 ▨

- Increased speed, high performance, superior quality and a unique design make it perfect for professionals
- 'Gills' on segments help create positive water flow

DIAMETER INCHES (MM)	METRIC SEGMENT DIMENSION L X W X H	NUMBER OF SEGMENTS	ARBOR MM	ITEM NO.	NET PRICE
12 (300)	40 x 3.2 x 15	19	60/50	543094070	\$226.00
14 (350)		23		543093633	\$267.00
16 (400)	40 x 3.4 x 15	26		543093642	\$287.00
18 (450)	40 x 3.8 x 15	28		543094072	\$411.00
20 (500)		30		543094074	\$442.00



Magnum™ XL Series Blade. ■💧🔪

- Notched sandwich segments reduce lateral friction of the 20 mm high segments, resulting in faster cuts
- Silent core reduces noise level of the blade. Use on >20 hp saws

DIAMETER INCHES (MM)	METRIC SEGMENT DIMENSION L X W X H	NUMBER OF SEGMENTS	ARBOR MM	ITEM NO.	NET PRICE
14 (350)	46 x 3.4 x 20	23	60/50	543070308	\$299.00
16 (400)	46 x 3.6 x 20	26		543070314	\$359.00
18 (450)	46 x 4.0 x 20	32		543070318	\$369.00



M10 Miter Blade. ■💧🔪

- Steel core to withstand stress of making miter cuts
- Cuts a large range of stone

DIAMETER INCHES (MM)	METRIC SEGMENT DIMENSION L X W X H	NUMBER OF SEGMENTS	ARBOR MM	ITEM NO.	NET PRICE
12 (300)	40 x 3.4 x 10	24	60/50	588847901	\$199.00
14 (350)	40 x 3.4 x 10	26		588847902	\$219.00
16 (400)	40 x 3.4 x 10	28		588847903	\$239.00
18 (450)	40 x 3.4 x 10	33		588847904	\$325.00



Q22 (Quartzite 22) Blade.

Quartzite, White Macaubus 💧🔪

- Made to cut the hardest stone in one pass
- 22 mm high segments featuring Patterned Diamond Technology for consistent performance and a longer life
- Silent core

DIAMETER INCHES (MM)	METRIC SEGMENT DIMENSION L X W X H	NUMBER OF SEGMENTS	ARBOR MM	ITEM NO.	NET PRICE
12 (300)	40 x 3.4 x 22	24	60/50	588693604	\$277.00
14 (350)	40 x 3.4 x 22	26		588693605	\$308.00
16 (400)	40 x 3.4 x 22	28		588693606	\$329.00
18 (450)	40 x 3.4 x 22	33		588693607	\$370.00



Diamax Cyclone Low HP Blade. ■ ■ 💧 ▬

- Great for low horsepower applications when cutting hard granites
- Ideal for use with saws like the Blue Ripper™

DIAMETER INCHES (MM)	METRIC SEGMENT DIMENSION L X W X H	NUMBER OF SEGMENTS	ARBOR MM	ITEM NO.	NET PRICE
14 (350)	40 x 3.2 x 12	26	60/50	542870011	\$219.00
16 (400)		28		542870012	\$299.00



Marble Blade. ■ 💧 ▬ Limestone

- Use with a wide range of horsepower - less than 15 hp to over 20 hp
- Silent core for reduced noise levels
- Cuts travertines and limestone

DIAMETER INCHES (MM)	METRIC SEGMENT DIMENSION L X W X H	NUMBER OF SEGMENTS	ARBOR MM	ITEM NO.	NET PRICE
12 (300)	40 x 2.8 x 7	21	60/50	543101008	\$199.00
14 (350)	40 x 3.2 x 7	25		543101007	\$209.00
16 (400)		28		543100744	\$249.00
18 (450)	40 x 3.8 x 7	32		543100746	\$309.00
20 (500)		36		543100747	\$359.00

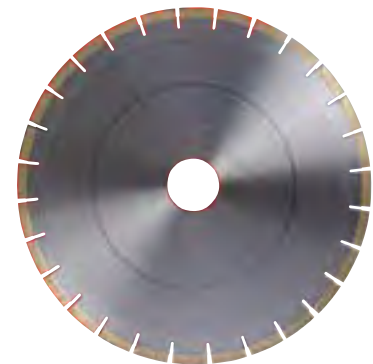

Porcelain + Dekton®. ■ ■ 💧 ■

- Ideal for cutting Dekton® and other hard materials

DIAMETER INCHES (MM)	ARBOR MM	ITEM NO.	NETPRICE
14 (350)	60/50	542773285	\$119.00



Bridge Saw Rodding Blade. ■ ■ ■ ■

- Standard core, long life and cuts all types of granite
- Full 1/4" wide to facilitate large rodding or grooving jobs

DIAMETER INCHES (MM)	METRIC SEGMENT DIMENSION L X W X H	NUMBER OF SEGMENTS	ARBOR MM	ITEM NO.	NET PRICE
14 (350)	40 x 6.35 x 9.5	25	60/50	542866772	\$283.00



Granite Rodding Blades. ■ ■ ■ ■

- Full 1/4" thick segments to make rodding grooves in one pass
- Available in 7"

DIAMETER INCHES (MM)	METRIC SEGMENT DIMENSION L X W X H	ARBOR INCHES	ITEM NO.	NET PRICE
4 (100)	.250 (6.35)	7/8-5/8	542861194	\$46.00
4.5 (115)			542860295	\$50.00



Doublecut Rodding Blade. ■ ■ ■ ■

- Can make a rodding groove in one pass thanks to the double-row of segments

DIAMETER INCHES (MM)	METRIC SEGMENT DIMENSION L X W X H	ARBOR INCHES	ITEM NO.	NET PRICE
4 (100)	.250 (6.35)	7/8-5/8	542866773	\$46.00
4.5 (115)			542866774	\$50.00
7 (178)		7/8-5/8 DM	542866775	\$67.00

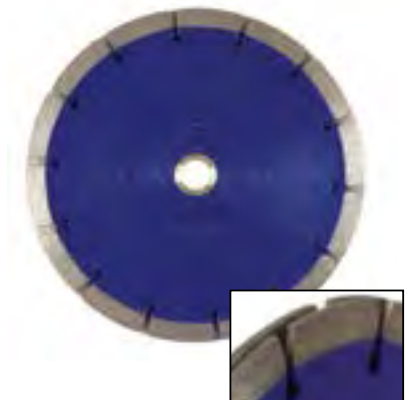

SMALL DIAMETER BLADES

- ⚙️ – Dry
- – Continuous
- ⏸️ – Segmented
- 🟡 – Marble
- 🟦 – Porcelain
- 💧 – Wet
- 🔄 – Turbo
- 🟩 – Granite
- – Engineered Stone

Magnum™ XT Blade. ■ ■ 💧 ⚙️ 🔄

- Fast, smooth cutting blade with excellent life
- A quad-hole pattern for use with stone saws

SEGMENT HEIGHT - 8 MM			
DIAMETER INCHES (MM)	ARBOR INCHES	ITEM NO.	NET PRICE
5 (125)	7/8-5/8	542863281	\$33.00
6 (155)		542863282	\$41.00
7 (178)	7/8-5/8 DM	542863283	\$57.00



Diamax Hurricane™ Blade. ■ ■ 💧 ⚙️ 🔄

- An economical, thick core turbo blade

SEGMENT HEIGHT - 8 MM			
DIAMETER INCHES (MM)	ARBOR INCHES	ITEM NO.	NET PRICE
4 (101)	7/8-5/8	542866873	\$24.00
4.5 (115)		542866874	\$25.00
5 (125)		542866875	\$27.00
6 (155)		542866876	\$36.00
7 (178)	7/8-5/8 DM	542866877	\$44.00
8 (200)		542866878	\$46.00



Magnum™ Free Cut. ■ ■ 💧 ⚙️ 🔄

- Leaves a smoother finish than standard turbo blades
- Reinforced center for more accurate cuts
- Great price to performance ratio

SEGMENT HEIGHT - 8 MM			
DIAMETER INCHES (MM)	ARBOR INCHES	ITEM NUMBER	NET PRICE
5 (125)	7/8 - 5/8	501082201	\$28.00
6 (155)		501082202	\$33.00
7 (178)	7/8 - 5/8 DM	501082203	\$41.00
8 (200)		501082204	\$47.00



NEW

Fury™ Turbo. ■ ■ ■ ■ ■

- Features a soft bond and a narrow rib rim
- Economical blade with a quad-hole flush pattern for use with stone saws

SEGMENT HEIGHT - 10 MM			
DIAMETER INCHES (MM)	ARBOR INCHES	ITEM NO.	NET PRICE
4 (101)	20 mm	542862043	\$16.00
4 (101)	7/8-5/8	542862041	\$19.00
4.5 (115)		542862044	\$22.00
5 (125)		542862046	\$25.00
5.25 (131)		542865304	\$27.00
6 (155)	7/8-5/8 DM	542862048	\$27.00
7 (178)		542862051	\$39.00
8 (200)*		542862053	\$45.00

*Does not have quad flush holes.



Diamant Bort Recommended

ProTec™ + Blade. ■ ■ ■ ■ ■

- Features ProTec(tive) segments which provide more contact with diamonds and therefore a longer life
- Newly designed to perform better on granite

SEGMENT HEIGHT - 8 MM			
DIAMETER INCHES (MM)	ARBOR INCHES	ITEM NO.	NET PRICE
4.5 (115)	7/8 - 5/8	588793401	\$19.00
5 (125)*		588793402	\$21.00
6 (155)*		588793403	\$23.00
7 (178)	7/8 - 5/8 DM	588793404	\$29.00
8 (200)		588793405	\$37.00

*flush cut holes



SMALL DIAMETER BLADES

⚙️ - Dry ■ - Continuous ▩ - Segmented ■ - Marble ■ - Porcelain
💧 - Wet 🔄 - Turbo ■ - Granite ■ - Engineered Stone

DX Turbo Blade. ■ ■ 💧 ⚙️ 🔄

- Economical turbo blades for cutting granite, tile or other natural stone
- Each size packaged in groups of 10



DIAMETER INCHES (MM)	ARBOR INCHES	ITEM NO.	NET PRICE
4.5 (115)	7/8-5/8	542861280	\$77.00
5 (125)		542861340	\$98.00
7 (178)	7/8-5/8 DM	542861281	\$123.00

Black Flush Cut Blade. ■ ■ 💧 ⚙️ 🔄 ▩

- T-segments on both sides help remove debris easily. Blade is .155 mm thick
- Higher contact with diamonds leads to increased blade life



DIAMETER INCHES (MM)	ARBOR INCHES	ITEM NO.	NET PRICE
5 (125)	7/8-5/8	542866807	\$81.00

Electroplated Flush Cut Blade. ■ 💧 ⚙️ ▩ Limestone

- An economical general purpose blade

DIAMETER INCHES (MM)	ARBOR INCHES	ITEM NO.	NET PRICE
4.5 (115)	7/8	542867156	\$31.00
5 (125)*		542867159	\$41.00
5 (125)		542867157	\$36.00
7 (178)		542867158	\$41.00

*with dots and quad holes



Electroplated Marble Blade.      Limestone

- A premium, general purpose blade
- Electroplated on both sides and cuts with minimal chipping

DIAMETER INCHES (MM)	ARBOR INCHES	ITEM NO.	NET PRICE
5 (125)	7/8	542866921	\$77.00
6 (155)		542866922	\$88.00



Diamax Super Cyclone Electroplated Marble Blade.

     Limestone

- A premium electroplated blade for precise cuts on marble and other soft stones

DIAMETER INCHES (MM)	ARBOR INCHES	ITEM NO.	NET PRICE
4 (101)	20 mm	542779035	\$46.00
4.5 (115)	7/8-5/8	542779036	\$50.00
5 (125)		542779037	\$56.00
6 (155)		542779038	\$61.00
7 (178)	7/8-5/8 DM	542779039	\$81.00



Small Diameter Blade Accessories.



A	Quick Change/Flush Mount Adapter	542420404	\$15.00
	Replacement Screws	542860086	\$0.15



Fury™ Turbo Curvo Blade. ■ ■ 💧 ☀ 🔄

- Smoother edge and perfect for sink openings
- Fits most electric angle grinders

RPMS UP TO 4,500			
DIAMETER INCHES (MM)	ARBOR INCHES	ITEM NO.	NET PRICE
4.5 (115)	7/8-5/8	542861228	\$46.00
5 (125)		542861229	\$50.00



Fury™ Segmented Curve Blade. ■ ■ 💧 ☀ ▨

- Segments on both sides of the core to prevent binding in the cut
- Ideal for sink openings or other curve applications

RPMS UP TO 4,500			
DIAMETER INCHES (MM)	ARBOR INCHES	ITEM NO.	NET PRICE
4.5 (115)	7/8-5/8	542862301	\$61.00
5 (125)		542862305	\$71.00



Economaster Curve Blade. ■ ■ 💧 ☀ ▨

- Economical, electroplated blade for cutting sink openings

RPMS UP TO 4,500			
DIAMETER INCHES (MM)	ARBOR INCHES	ITEM NO.	NET PRICE
5 (125)	7/8	542862122	\$33.00
6 (155)		542862123	\$39.00



Milling Wheel. ■ ■ 💧 ▨

- Used to plane and mill mortar base tables or reduce backsplashes from 3 cm to 2 cm

DIAMETER INCHES (MM)	ARBOR INCHES	WIDTH INCHES (MM)	NUMBER OF SEGMENTS	ITEM NO.	NET PRICE
12 (300)	50	1-1/2 (40)	40	542860002	\$1,050.00
14 (350)			45	542860003	\$1,095.00



Retipping available, \$12 per segment
 Additional arbor sizes available, add \$50 net

Sintered Wheels. 

- Wheels contain a continuous rim of diamonds
- Perfect for smoothing out cut sink openings

SIZE INCHES	GRIT	THREAD	ITEM NO.	NET PRICE
2 x 2	36	5/8" - 11	542861286	\$112.00
	60		542861287	\$112.00
	120		542861288	\$112.00
3 x 1-1/2	36		542861290	\$123.00
	60		542861291	\$123.00
	120		542861292	\$123.00



Diamax Cyclone™ Zero Tolerance Wheels. 

- Coarse segments with diamond impregnated resin between the segments to minimize chipping
- Perfect for smoothing out cut sink openings

SIZE INCHES	THREAD	ITEM NO.	NET PRICE
1 x 1-5/8*	5/8" - 11	542866916	\$112.00
2 x 1-5/8		542860004	\$133.00
3 x 1-5/8		542861379	\$143.00

*Not resin filled



Segmented Drum Wheels. 

- Used for traditional removal and smoothing
- Perfect for smoothing out cut sink openings

SIZE INCHES	THREAD	ITEM NO.	NET PRICE
2 x 1-5/8	5/8" - 11	542862276	\$92.00
3 x 1-5/8		542862278	\$112.00



ZERO TOLERANCE/ SINK WHEELS

⚙️ - Dry ■ - Continuous ▬ - Segmented ■ - Marble ■ - Porcelain
💧 - Wet 🔄 - Turbo ■ - Granite ■ - Engineered Stone

Brazed Bonded Sink Wheels. ■ ■ ■ 💧 ⚙️

- Wheels are vacuum brazed - diamonds are baked and become part of the steel, increasing strength and wheel life

SIZE INCHES	GRIT	THREAD	ITEM NO.	NET PRICE
1 x 2	50	5/8" - 11	542860255	\$92.00
	100		542861380	\$92.00
	200		542867066	\$102.00
2 x 2	50		542860005	\$102.00
	100		542860006	\$102.00
	200		542860007	\$102.00
3 x 1-1/2*	50		542860008	\$143.00

* Diamonds on bottom



Brazed Bonded Sink Wheels. ■ ■ ■ 💧 ⚙️

- Wheels are vacuum brazed - diamonds are baked and become part of the steel, increasing strength and wheel life

SIZE INCHES	GRIT	THREAD	ITEM NO.	NET PRICE
2 x 2	30	5/8"-11	542862408	\$153.00
	50		542860065	\$143.00
	100		542860066	\$143.00
3 x 1.5	50		542860067	\$226.00
	100		542860068	\$226.00



Zero Tolerance Cutting Tools. ■ ■ ■ 💧

- To be used on Wizard and other radial arm machines with high-speed spindles

DESCRIPTION	ITEM NO.	NET PRICE
Auxiliary spindle adapter 1/2" gas (overall length 3-7/8")	542861249	\$77.00
Sleeve for adapter (1-3/4" length)	542861248	\$26.00
Thick sleeve (1" O.D.) x 1-3/4" L	542862847	\$31.00
Standard replaceable tip for hard granite	542861250	\$77.00
Long life replaceable tip for all granite	542863222	\$56.00
Standard replaceable tip for marble	542861367	\$102.00



Wet Polishing Drums. ■ ■ ■ ●

- Center water feed for thorough water distribution

SIZE INCHES	GRIT	ITEM NO.	NET PRICE
2 x 2	50	542862070	\$25.00
	100	542862071	\$25.00
	200	542862072	\$25.00
	400	542862073	\$25.00
	800	542862074	\$25.00
	1,500	542862075	\$25.00
	3,000	542862076	\$25.00
	Buff	542862077	\$25.00



Sinkits™.

- Save time and money when installing sinks
- Works best with our 1/4" bits

DESCRIPTION	ITEM NO.	NET PRICE
Order in boxes of 50	542869553	\$1.45ea
Cost comparison based on 8 holes per sink		Difference in cost compared to Sinkits™
T-31	> 16 min	\$29.01
Glue in lead anchors	> 20 min	\$38.28
Tap in lead anchors	> 15 min	\$24.78
Glue studs	> 10 min	\$15.91
G-Clips	> 10 min	\$32.89
Sink harness	> 15 min	\$20.04



Sinkits™ Accessories.

DESCRIPTION	ITEM NO.	NET PRICE
5/8-11 1/4" non-coring bit	542866778	\$36.00
Sinkits™ Stop Blok	588711301	\$35.00
CNC Non-Coring Bit 1/4"	542868335	\$52.00

Anchor Bits for T31 Mounting. ■ ■ ●

SHANK/ COLLET SIZE INCHES (MM)	FOR BOLT SIZE	ITEM NUMBER	NET PRICE
3/8 (9.5)	3/16 (4.7)	542861296	\$24.00
	1/4 (6)	542861297	\$29.00
1/4 (6)	3/16 (4.7)	542861343	\$24.00
	1/4 (6)	542861344	\$26.00

- Used for bowl-hole mounting systems.
- Vacuum brazed



CORE BITS

- ⚙️ - Dry
- - Continuous
- ▮ - Segmented
- - Marble
- - Porcelain
- 💧 - Wet
- ⚡ - Turbo
- - Granite
- - Engineered Stone



Magnum™ GB



- Fast cutting and long life
- Recommended RPMs 6-8,000

USEABLE LENGTH INCHES(MM) 2.5(63.5) THREAD 5/8" -11		
DIAMETER INCHES (MM)	ITEM NO.	NET PRICE
1 (25)	542865368	\$57.00
1-1/4 (32)	542865034	\$62.00
1-3/8 (35)	542865035	\$67.00
1-1/2 (38)	542865036	\$71.00
1-3/4 (45)	542866998	\$77.00
2 (51)	542865315	\$81.00
2-1/2 (63)	542868213	\$92.00
3 (75)	542868214	\$102.00



Fury™ Gold Turbo Wet



- Works on CNC machines
- Recommended RPMs up to 3,000

USEABLE LENGTH INCHES 2.5(63.5) THREAD 5/8" -11		
DIAMETER INCHES (MM)	ITEM NO.	NET PRICE
1 (25)	542862105	\$46.00
1-1/4 (32)	542862106	\$48.00
1-3/8 (35)	542862107	\$50.00
1-1/2 (38)	542862108	\$54.00
2 (51)	542862109	\$61.00
2-1/2 (63)	542865276	\$77.00



T-SHAPE SEGMENT

Fast Fury™



- Takes less than 30 sec to drill
- Recommended RPMs 7,000

USEABLE LENGTH INCHES(MM) 2.75(70) THREAD 5/8" -11		
DIAMETER INCHES (MM)	ITEM NO.	NET PRICE
1-1/4 (32)	542867447	\$67.00
1-3/8 (35)	542867448	\$72.00
1-1/2 (38)	542867449	\$77.00
2 (51)	542866780	\$88.00



Heavy-Duty Non-Coring Bit



- Drill small diameter holes with a center or external water feed

USEABLE LENGTH INCHES(MM) 2.0(51) THREAD 5/8" -11		
DIAMETER INCHES (MM)	ITEM NO.	NET PRICE
3/16 (4.75)	542866777	\$29.00
1/4 (6.35)	542866778	\$36.00
3/8 (9.52)	542866779	\$43.00
1/2 (12.7)	542863275	\$49.00



Rambo™ PT



- Patterned Diamond segments
- Recommended RPMs 8-10,000

USEABLE LENGTH INCHES(MM) 2.5(63.5) THREAD 5/8" -11		
DIAMETER INCHES (MM)	ITEM NO.	NET PRICE
1-1/4 (32)	542867466	\$77.00
1-3/8 (35)	542867467	\$80.00
1-1/2 (38)	542867468	\$82.00
1-3/4 (45)	542867469	\$88.00
2 (51)	542867470	\$103.00



Standard Non-Coring Bit



- Drills small diameter holes in stone with a 1/2" drill chuck. Can be used with a center or external water feed

USEABLE LENGTH INCHES(MM) 1.5(40)* - 2.67(67) THREAD SMOOTH SHANK		
DIAMETER INCHES (MM)	ITEM NO.	NET PRICE
3/16 (5)*	543015229	\$32.00
0.275 (7)	543015198	\$32.00
5/16 (8)	543015232	\$32.00
3/8 (10)	543015207	\$36.00
7/16 (11)	543015205	\$52.00
.472 (12)	543015203	\$52.00
1/2 (13)	543015201	\$56.00



Fury™ T3+ Thinwall



- Perfect for small jobs.
- Recommended RPMs see chart pg. 7

USEABLE LENGTH INCHES(MM) 2.75(70) THREAD 5/8" -11		
DIAMETER INCHES (MM)	ITEM NO.	NET PRICE
3/8 (10)	542870032	\$26.00
1/2 (13)	542870033	\$28.00
5/8 (16)	542870034	\$30.00
3/4 (19)	542870035	\$33.00
1 (25)	542870036	\$40.00
1-1/4 (32)	542870037	\$46.00
1-3/8 (35)	542870038	\$49.00
1-1/2 (38)	542870039	\$53.00
1-5/8 (41)	542870040	\$57.00
1-3/4 (45)	542870041	\$61.00
2 (51)	542870042	\$67.00
2-1/4 (57)	542870043	\$72.00
3 (76)	542870044	\$78.00



Ultra GB



- 7/8" and larger are laser welded segmented bits
- Recommended RPMs see chart pg. 7. Custom sizes available

USEABLE LENGTH INCHES(MM) 2(51) THREAD 5/8" -11		
DIAMETER INCHES (MM)	ITEM NO.	NET PRICE
3/8 (10)*	542860009	\$43.00
1/2 (13)*	542860010	\$43.00
5/8 (16)*	542860011	\$44.00
3/4 (19)*	542860012	\$47.00
7/8 (22)	542860013	\$60.00
1 (25)	542860014	\$49.00
1-1/8 (28)	542860015	\$50.00
1-1/4 (32)	542860016	\$55.00
1-3/8 (35)	542860017	\$56.00
1-1/2 (38)	542860018	\$58.00
1-5/8 (41)	542860019	\$61.00
1-3/4 (45)	542860020	\$62.00
2 (51)	542860021	\$62.00
2-1/4 (57)	542860023	\$93.00
2-3/8 (60)	542860088	\$113.00
2-1/2 (63)	542860024	\$82.00
3 (76)	542860022	\$82.00
4 (101)	542860025	\$133.00
4-1/4 (108)	542860089	\$140.00

* Crown Bits



Wizard™ ThinWall



- Designed for Wizard-type machines
- Recommended RPMs of 2,000-2,500

USEABLE LENGTH INCHES(MM) 2.75(70) THREAD 5/8" -11		
DIAMETER INCHES (MM)	ITEM NO.	NET PRICE
1-3/8 (35)	542867195	\$81.00

Core Bit Accessories

	DESCRIPTION	ITEM NO.	NET PRICE
A	Water Rings (1-1/2" and 3")	542173523	\$8.00
B	Adapter 3/8" triangular shank to 5/8" - 11 male thread	542866803	\$12.00
C	Adapter 1/2" shank to 5/8"-11 male thread	542860085	\$18.00
D	Converts standard 1/2" electric drill to 5/8"-11 male thread	542420106	\$18.00
E	1/2" gas male to 5/8"-11 male thread	542860082	\$35.00
F	Adapter 3/8" shank to 5/8"-11 male thread	542420706	\$11.00
F	Adapter 3/8" triangular shank to 5/8"-11 male thread	542866803	\$12.00
G	Conditioning/sharpening stick - 120 grit	542862322	\$5.09
H	Conditioning/sharpening stick - 60 grit	542860087	\$10.00



Call to Order: 1.800.461.9589

Porcelain + Blades. ■ 💧 ■

- Continuous rim and perfect for cutting porcelain

DIAMETER INCHES (MM)	ARBOR INCHES	ITEM NO.	NET PRICE
8 (200)	5/8	542862265	\$43.00
10 (250)		542860069	\$55.00



Euro Rim Blades. ■ ■ 💧 ■

- Continuous, thin rim for precision cutting
- Perfect for fast, chip-free cutting of porcelain tile, granite, quarry tile, and dense floor tile

DIAMETER INCHES (MM)	ARBOR INCHES	ITEM NO.	NET PRICE
4 (100)	5/8	542860070	\$16.00
8 (200)	7/8 - 5/8 DM	542860071	\$32.00
10 (250)		542860072	\$40.00

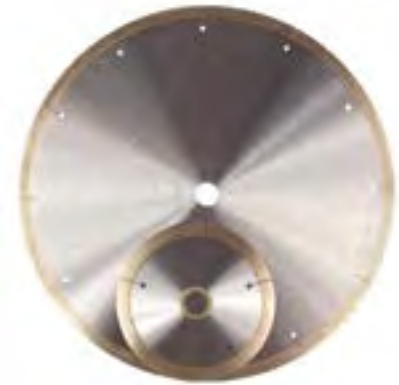

Conditioning Sticks.

- Used to dress dull diamond blades and bits
- Best to use with water

SIZE INCHES (MM)	GRIT	ITEM NO.	NET PRICE
1 x 2 x 8 (25 x 51 x 203)	120	542862322	\$5.09
1 x 2 x 8 (25 x 51 x 203)	60	542860087	\$10.00









CUP WHEELS	28
SHAPING WHEELS	31
PROFILE WHEELS	32
ROUTER BITS	34

CUP WHEELS

☀ - Dry ■ - Continuous ▨ - Segmented ■ - Marble ■ - Porcelain
💧 - Wet 🔄 - Turbo ■ - Granite ■ - Engineered Stone

Vibration Reducing Cup Wheel II. ■ ■ 💧 ☀ 🔄

- The rubber back absorbs vibration, making the wheels quieter and easier on the operator
- Unique face design limits chipping



DIAMETER INCHES (MM)	GRIT	THREAD	ITEM NO.	NET PRICE
4 (100)	Coarse	5/8"-11	587477801	\$59.00
	Fine		587477802	

Magnum™ Gold Cup Wheel. ■ ■ 💧 ☀ 🔄

- General purpose, turbo rim cup wheel. A top seller!
- Steel back



DIAMETER INCHES (MM)	GRIT	THREAD	ITEM NO.	NET PRICE
4 (100)	Coarse	5/8"-11	542774649	\$61.00
	Medium		542774650	

Volcano Single-sided Wheel. ■ ■ 💧 ☀ 🔄

- Great for shaping
- Can be used either wet or dry with polishers, maximum 3,000 RPMs
- Perfect for removing mesh



DIAMETER INCHES (MM)	GRIT	THREAD	ITEM NO.	NET PRICE
4 (100)	16	5/8"-11	542868272	\$33.00
	24		542868273	
	30		542867147	
	60		542867148	
	120		542867149	

Diamax Hurricane™ Cup Wheel. ■ ■ 💧 ☀ 🔄

- Aggressive turbo rim and an aluminum back



DIAMETER INCHES (MM)	GRIT	THREAD	ITEM NO.	NET PRICE
4 (100)	Coarse	5/8"-11	542868017	\$71.00
	Medium		542868018	
	Fine		542868019	

MB Supreme Cup Wheel. ■ ■ ■ Limestone

- Vacuum sintered metal bond
- Aggressive as a segmented cup wheel; leaving a smoother finish
- Rubber back eliminates vibration for ease of use

DIAMETER INCHES (MM)	GRIT	THREAD	ITEM NO.	NET PRICE
4(100)	30	5/8"-11	589243901	\$79.00
	50		542779343	



Magnum™ Supreme Twin Cup Wheel. ■ ■ ■ ⚙️ ↻

- General purpose, smooth grinding wheel
- Aluminum back

DIAMETER INCHES (MM)	GRIT	THREAD	ITEM NO.	NET PRICE
4 (100)	Coarse	5/8"-11	542863395	\$61.00
	Medium		542863396	
	Fine		542863397	



Magnum™ Silver Cup Wheel. ■ ■ ■ ⚙️ ↻

- Continuous rim/turbo rim
- General purpose grinding

DIAMETER INCHES (MM)	GRIT	THREAD	ITEM NO.	NET PRICE
4(100)	Coarse	5/8"-11	542860044	\$50.00
	Medium		542860045	
	Fine		542860046	
4(100)*	Coarse		542860047	
	Medium		542860048	
	Fine		542860049	



*Continuous rim



CUP WHEELS

⚙️ - Dry ■ - Continuous ▨ - Segmented ■ - Marble ■ - Porcelain
💧 - Wet 🔄 - Turbo ■ - Granite ■ - Engineered Stone

Premium Resin Filled Cup Wheel. ■ ■ 💧 ⚙️

- High quality wheels reduce chipping
- Long life

DIAMETER INCHES (MM)	GRIT	THREAD	ITEM NO.	NET PRICE
4 (100)	Coarse	5/8"-11	588039001	\$81.00
	Medium		588039002	
	Fine		588039003	



NEW

Resin Filled Cup Wheel. ■ ■ 💧 ⚙️

- Resin filled to leave a smooth finish
- Great result at economy price

DIAMETER INCHES (MM)	GRIT	THREAD	ITEM NO.	NET PRICE
4 (100)	Coarse	5/8"-11	542779009	\$65.00
	Medium		542779010	
	Fine		542779011	



NEW

Magnum™ Gray Cup Wheel. ■ ■ 💧 ⚙️ 🔄

- Steel back
- Smooth grinding in stone

DIAMETER INCHES (MM)	GRIT	THREAD	ITEM NO.	NET PRICE
4 (100)	Coarse	5/8"-11	542863181	\$71.00
	Medium		542863182	
	Fine		542863183	
5 (125)	Coarse		542863184	



Diamax Cyclone™ Cluster Wheels. ■ ■ 💧 ⚙️ 🔄

- Designed for rapid removal of mesh backing, epoxy coatings, paint, all adhesive materials and rust
- Can be used on granite, concrete and steel

DIAMETER INCHES (MM)	ITEM NO.	NET PRICE
4 (100)	542868295	\$81.00
5 (125)	542868296	\$92.00
6 (155)	542868297	\$123.00
7 (178)	542868298	\$153.00



Magnum™ Cutter/Grinding Wheel. ■ ■ ● ⚙️ ↻

- Wheel is vacuum brazed, meaning diamonds are baked and become part of the steel, increasing strength and wheel life
- Thin profile and diamonds on the back side lip are perfect for reaching into tight corners to "scoop" and "shape"
- Not recommended for flat surfaces

DIAMETER INCHES (MM)	GRIT	THREAD	ITEM NO.	NET PRICE
4 (100)	30	5/8"-11	542866639	\$102.00
5 (125)	30		542863611	\$123.00
5 (125)	50		542867326	\$92.00



Grinder/Cutter Wheel. ■ ■ ● ⚙️ ↻

- Used to cut and grind with one tool

DIAMETER INCHES (MM)	ARBOR	THREAD	ITEM NO.	NET PRICE
5 (125)	7/8" with flush mount	5/8"-11	542779078	\$59.00
6 (150)			542870061	\$69.00



Quad adaptor included

Dual-sided Vacuum Brazed Wheel. ■ ■ ■ ● ⚙️ ↻

- Grinder/profile wheel featuring vacuumed brazed technology, which bakes the diamonds into the steel, increasing strength and life
- Reverse the flush mount adapter and use both sides
- Recommended RPMs of 3,000-6,000

DIAMETER INCHES (MM)	GRIT	THREAD	ITEM NO.	NET PRICE
4 (100)	50	5/8"-11	542867454	\$61.00
5 (125)	50 with cooling holes		542867456	\$81.00
	50		542866837	



Single-sided Convex Wheel. ■ ■ ● ⚙️

- Features vacuum brazed technology, which bakes the diamonds into the steel, increasing strength and life
- Recommended RPMs of 3,000-6,000

DIAMETER INCHES (MM)	GRIT	THREAD	ITEM NO.	NET PRICE
4.5 (114)	30	5/8" - 11	501082001	\$79.00
	60		501082002	\$79.00
	120		501082003	\$79.00



Premium Profile Wheels. ■ ■ ■ 💧 Limestone

- Used for profiling edges
- Longest life when cutting marble

DESCRIPTION	DIAMETER INCHES (MM)	ITEM NO.	NET PRICE
3/8" Radius	6 x 5/8 (152 x 16)	542860285	\$67.00
1/2" Radius		542860286	\$67.00
45° Bevel		542860287	\$67.00
Ogee		542860288	\$67.00



A = Convex radius = 5/32"
 B = Concave radius = 3/16"
 Wheels are 1/2" wide

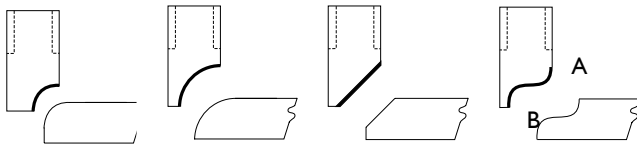

Profile Wheels. ■ ■ ■ ■ 💧 Limestone

- Vacuum brazed wheels
- Longest life when profiling edges of granite

DESCRIPTION	DIAMETER INCHES (MM)	THICKNESS INCHES (MM)	ITEM NO.	NET PRICE
1/2" Radius	6 (150)	3/8 (10)	542861312	\$133.00
3/8" Radius		1/4 (6)	542861313	\$133.00
3/8" Radius	8 (200)		542861316	\$153.00



Brazed Profiler for Bowl Holes. ■ ■ ■ 💧 Limestone

- Designed using vacuum brazed technology to make quick 3/8" or 1/2" profiles on granite, marble or porcelain tile utilizing 5/8"-11 water fed grinders
- Minimum 3,000 RPMs
- Call for other shapes

DESCRIPTION	ITEM NO.	NET PRICE
7 mm Bevel	542868181	\$102.00
3/8" Bevel	542867163	\$133.00
1/2" Radius	542868184	\$133.00
3/8" Radius	542868212	\$133.00











Grinder not included





ROUTER BITS

 - Dry
  - Continuous
  - Segmented
  - Marble
  - Porcelain
 - Wet
  - Turbo
  - Granite
  - Engineered Stone

A Fury™ Router Bits.

- Fast cutting, minimum chipping and long life wheels come in more than 35 profiles. Custom profile router bits can be made within 1-2 weeks, call 800-845-1805 for details
- P3 bits are available in 1-2 weeks
- Recommended RPMs of 3,000-6,000

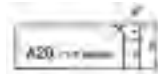

	DESCRIPTION	A20/30 1/4" RADIUS		A20/30 3/8" RADIUS	
A	Fury™ Coarse P1	542861481	\$256.00	542861482	\$256.00
A	Fury™ Fine P2	Call	\$256.00	Call	\$256.00
B	Fury™ Segmented P0				

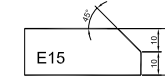
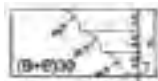

	DESCRIPTION	B+B 30 TRIPLE WATERFALL		E15 BEVEL	
A	Fury™ Coarse P1	542862019	\$504.00	542865352	\$184.00
A	Fury™ Fine P2	542862020	\$504.00	Call	\$184.00
B	Fury™ Segmented P0				



	DESCRIPTION	F30 OGEE		FV 40 OGEE/BULLNOSE*		H20 DUPONT	
A	Fury™ Coarse P1	542861495	\$318.00	542862021	\$500.00	542861497	\$221.00
A	Fury™ Fine P2	542861496	\$318.00	542862022	\$500.00	542861498	\$221.00
B	Fury™ Segmented P0	542867015	\$380.00				

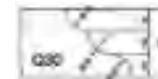

	DESCRIPTION	O20		O30		Q20		Q30	
A	Fury™ Coarse P1	542862003	\$277.00	542862005	\$298.00	542862007	\$277.00	542862009	\$298.00
A	Fury™ Fine P2	542862004	\$277.00	542862006	\$298.00	542862008	\$277.00	542862010	\$298.00
B	Fury™ Segmented P0								

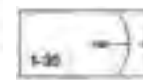

	DESCRIPTION	V40 FULLBULL		V50 FULLBULL		V60 FULLBULL		1-30 FRENCH BULLNOSE	
A	Fury™ Coarse P1	542862015	\$401.00	542862024	\$500.00	542862017	\$720.00	542862026	\$298.00
A	Fury™ Fine P2	542862016	\$401.00	542862025	\$500.00	542862018	\$720.00	542862027	\$298.00
B	Fury™ Segmented P0								

B Fury™ Segmented Position "0". ■ ■ ■ ■ ■

- Segmented for super fast cutting with minimum chipping
- Can be used before Pos. 1 Fury Router Bits to save time and tool life

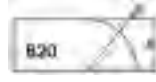

	B15 1/2 BULLNOSE (DEMI)		B20 LARGE RADIUS		B30 LARGE RADIUS	
A	542863065	\$256.00	542861483	\$267.00	542861485	\$308.00
A	542863066	\$256.00	542861484	\$267.00	542861486	\$308.00
B					542867017	\$339.00

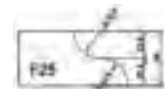
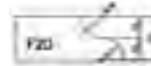
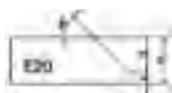

	E20 BEVEL		E30 BEVEL		F20 OGEE		F25 OGEE	
A	542861487	\$221.00	542861489	\$267.00	542861491	\$205.00	542861493	\$232.00
A	542861488	\$221.00	Call	\$267.00	542861492	\$205.00	542861494	\$232.00
B					542863673	\$226.00		

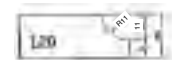
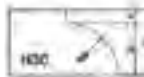



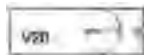





	H30 DUPONT		L20/30 COVE	
A	542861499	\$267.00	542862001	\$277.00
A	542862000	\$267.00	542862002	\$277.00
B				



	V20 FULLBULL		V30 FULLBULL	
A	542862011	\$267.00	542862013	\$329.00
A	542862012	\$267.00	542862014	\$329.00
B			542863675	\$339.00



ROUTER BITS

 - Dry
  - Continuous
  - Segmented
  - Marble
  - Porcelain
 - Wet
  - Turbo
  - Granite
  - Engineered Stone

Magnum™ Router Bits.



- Made in the USA
- Quick delivery of custom shapes, call 800-845-1805 to order
- Segmented P0 tools available
- P1-P3 continuous

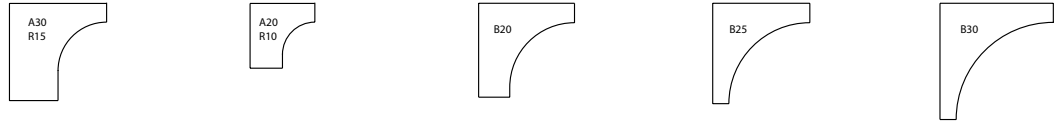

DESCRIPTION	A30	A20	B20 LARGE	B25	B30 LARGE RADIUS
Magnum™ P1	\$309.00	\$211.00	\$266.00	\$299.00	\$358.00
Magnum™ P2		\$211.00	\$266.00		\$358.00

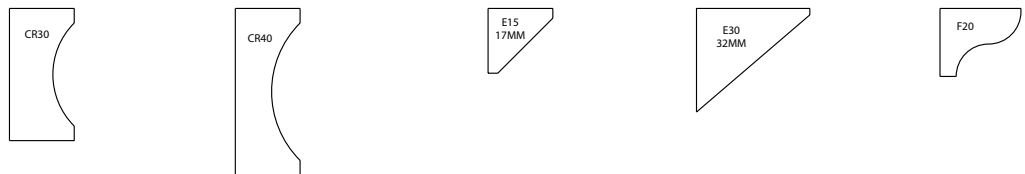

DESCRIPTION	CR30	CR40	E15 BEVEL	E30 BEVEL	F20 OGEE
Magnum™ P1	\$333.00	\$436.00	\$225.00	\$358.00	\$266.00
Magnum™ P2	\$333.00				\$266.00

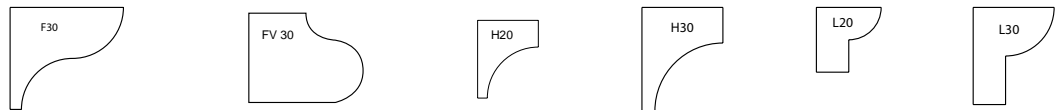

DESCRIPTION	F30 OGEE	FV 30 OGEE/BULLNOSE	H20 DUPONT	H30 DUPONT	L20 COVE	L30 COVE
Magnum™ P1	\$358.00	\$358.00	\$227.00	\$333.00	\$225.00	\$330.00
Magnum™ P2	\$358.00			\$333.00		

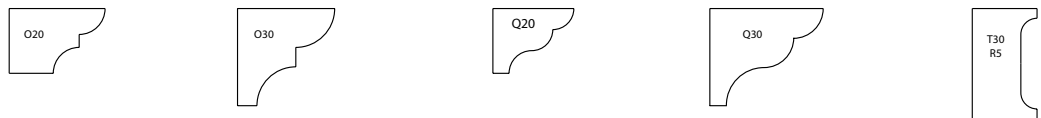

DESCRIPTION	O20	O30	Q20	Q30	T30
Magnum™ P1	\$235.00	\$350.00	\$235.00	\$350.00	\$309.00
Magnum™ P2		\$350.00		\$350.00	



DESCRIPTION	TP30	V20 FULLBULL	V30 FULLBULL	V40 FULLBULL
Magnum™ P1	\$355.00	\$240.00	\$361.00	\$472.00
Magnum™ P2	\$355.00	\$240.00	\$361.00	

Fury™ Double Breaker Bit. ■ ■ ● ▮

- The Fury™ Double Breaker Bits can be used on 2, 3 or 4 cm thick materials
- They can also be used on the top or bottom for ogee or demi shapes
- The bearing is removable to use as a X or Y breaker



ITEM NO.	NET PRICE
542866923	\$81.00



Router Bit Accessories.

DESCRIPTION	POSITION	SIZE INCHES (MM)	ITEM NUMBER	NET PRICE
V profile center bearing	1	1-7/16 (37)	542862347	\$12.00
V profile center bearing	2	1-13/32 (36)	542862348	
B profile bottom or top bearing	1		542862345	
B profile bottom or top bearing	2	1-3/8 (35)	542862346	
B profile extended bearing for bevel	1	2 (50)	542868039	\$21.00
Router Adapter		1/2 Gas/22.2mm/10mm Female	542867473	\$31.00



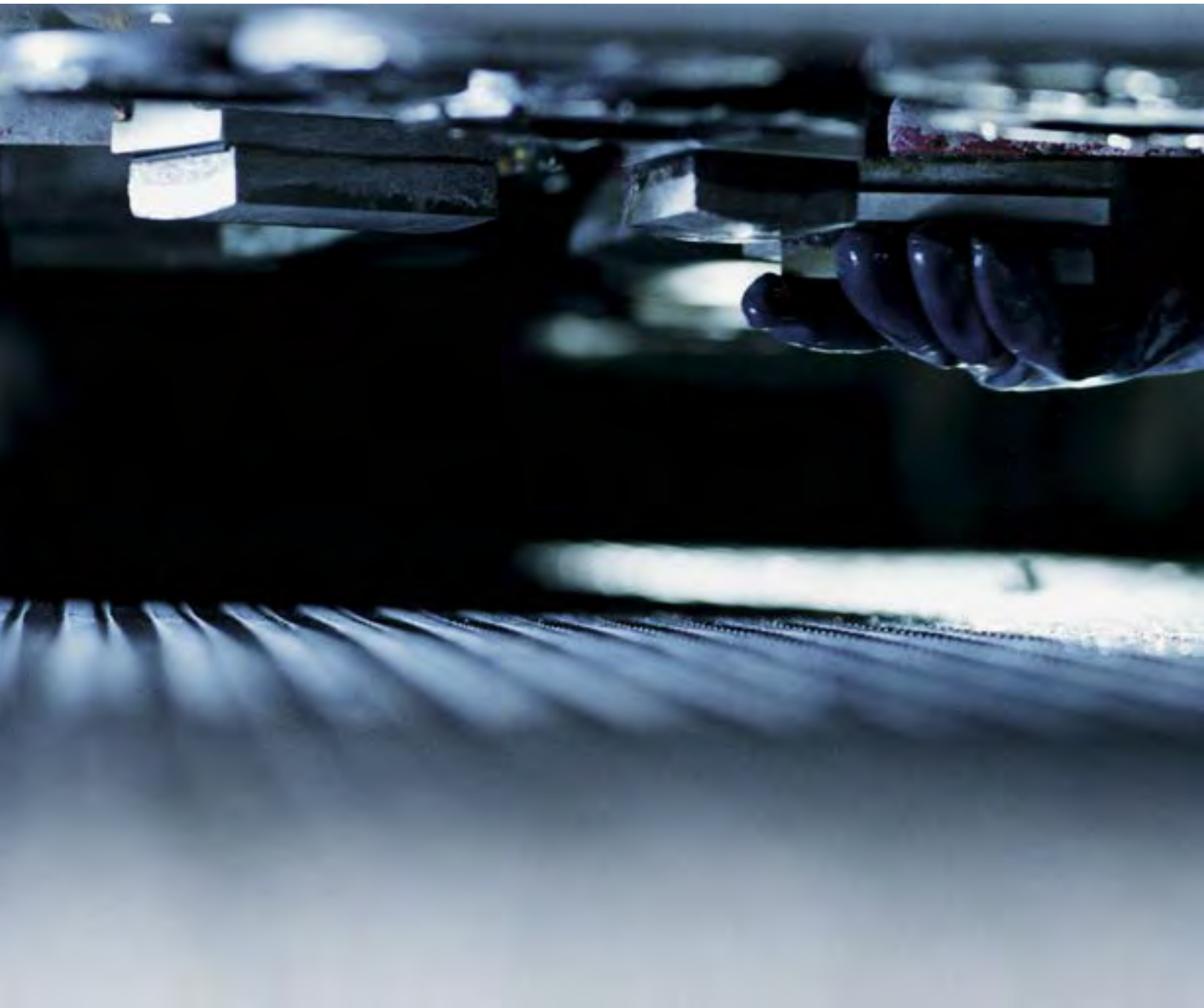



BACKERS	40
POLISHING PADS WET	42
POLISHING PADS DRY	48
POLISHING PADS WET 3-STEP	50
POLISHING PADS MARBLE	51
POLISHING PADS ENGINEERED STONE	51
HAND PADS	52
SPECIALTY PADS	53
AUTO-EDGE TOOLING	54



Specialty Backers.

- Lightweight and used for a variety of applications
- Available with rubber backs for use with various profiles, and also a rigid, aluminum back for flat polishing
- The Bowl Hole/Ogee Backer has a 3-1/4" rubber back for bowl hole and ogee polishing

DESCRIPTION	DIAMETER INCHES (MM)	MOUNT	ITEM NUMBER	NET PRICE
Ogee	3-1/4 (82.5)	5/8"-11	542866849	\$25.00
Metal Ogee, with Water Diverter	3-1/2 (89)		542867169	\$21.00
Felt, 1/4"	4 (100)	Velcro	542867155	\$9.00
CBH (cowboy hat) with Water Diverter	4 (100)	5/8"-11	542862395	\$15.00
Soft, with Water Diverter	2 (50)		542867342	\$25.00
Aluminum with Rubber Damper	4 (100)	5/8"-11 Snail Lock	542867170	\$41.00
Aluminum	4 (100)		542861310	\$41.00
	5 (125)		542862279	\$46.00



Soft Backer Pad.

- Available with rubber backs for use with various shapes
- Perfect for various applications on granite and marble

DESCRIPTION	DIAMETER INCHES (MM)	MOUNT	ITEM NUMBER	NET PRICE
Super Soft	3 (76)	5/8"-11	542867450	\$12.00
	4 (100)		542867451	\$14.00
Economy Rubber Soft	3 (76)		542862270	\$11.00
	3 (76)		542867166	\$9.00
	4 (100)		542862271	\$12.00
	4 (100)		542867167	\$10.00
	5 (125)		542862272	\$18.00
Soft, with Gold Water Diverter	4 (100)		542867344	\$26.00
	5 (125)		542867345	\$31.00
Soft, with Yellow Water Diverter	4 (100)		542867347	\$12.00
	5 (125)		542867349	\$16.00



Hard Backer Pads.

- Available with a rigid, hard polymer or aluminum back for flat polishing
- Some adapters feature a snail lock for quick changes, and some are available with a built-in water diverter

DESCRIPTION	DIAMETER INCHES (MM)	MOUNT	ITEM NUMBER	NET PRICE
Plastic, Rigid	4 (100)	Snail Lock + Velcro	542862205	\$12.00
Rigid, Hard Polymer	3 (76)	5/8"-11	542867055	\$11.00
	4 (100)		542867056	\$14.00
Economy Rubber Firm	3 (76)		542862273	\$11.00
	3 (76)		542867164	\$9.00
	4 (100)		542862274	\$12.00
	4 (100)		542867165	\$10.00
Aluminum, Rigid with Water Diverter	5 (125)		542862275	\$18.00
	3 (76)		542860059	\$18.00
	4 (100)		542860060	\$19.00
Aluminum	5 (125)		542860061	\$25.00
	3 (76)	542868066	\$15.00	
	4 (100)	5/8"-11 Snail Lock	542861310	\$41.00
	4 (100)	5/8"-11	542867168	\$16.00
Aluminum with Rubber Damper	5 (125)	5/8"-11 Snail Lock	542862279	\$46.00
	5 (125)	5/8"-11	542866872	\$20.00
	4 (100)	5/8"-11 Snail Lock	542867170	\$41.00



Ballistic Nylon Apron.

- Same material used for bullet proof vests, it is light weight and long lasting
- Replacement neck strap available

DESCRIPTION	ITEM NUMBER	NET PRICE
Apron	542868373	\$65.00
Sleeves	542868374	\$65.00
Replacement neck strap	542868467	\$15.00



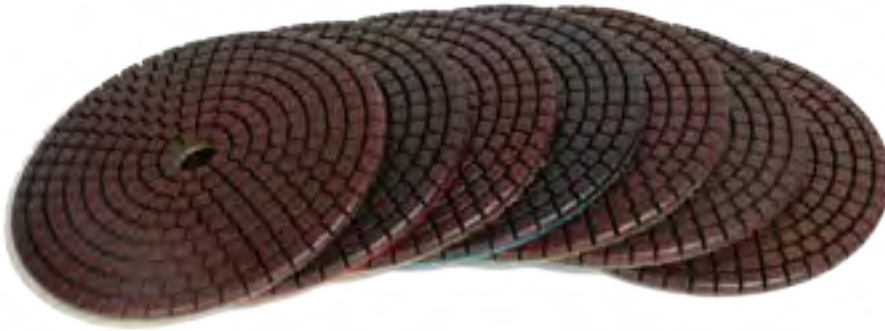

Magnum™ CP Flex Pads. ■ ■ 💧

- Made of a unique resin and copper phenolic. The copper allows the diamond to remain cool, while providing an extremely fine scratch and brilliant polish. Diamonds need to be exposed before use. When exposed, pads will turn a dark orange. Can last 3-5 times longer than traditional pads

GRIT	BACKER COLOR	3" (76 MM) ITEM NO.	PRICE	4" (101 MM) ITEM NO.	PRICE	5" (127 MM) ITEM NO.	NET PRICE
35	Purple	542867212	\$13.00	542863262	\$18.00	542867128	\$23.00
50	Light green	542867213		542863263		542867129	
100	Red	542867214		542863264		542867130	
200	Yellow	542867215		542863265		542867131	
400	Blue/Light blue	542867216		542863266		542867132	
800	Green	542867217		542863267		542767133	
1,500	Orange	542867218		542863268		542867134	
3,000	Pink	542867219		542863269		542867135	
5,000	Black	n/a		542863270		n/a	
Buff	White	n/a		n/a		n/a	
Buff	Black	n/a		n/a		n/a	

NEW



Mustang Pads. ■■■💧

- More economical pad with copper to increase life and reduce heat. Must be opened up before use
When exposed, pads will be an orange color

Magnum™ Elite Pads. ■■■💧

- Produces a high gloss on a variety of stone
- Beveled edges help keep edges from fraying

	GRIT	BACKER COLOR	4" (101 MM) ITEM NO.	NET PRICE
	35	Purple	587653801	\$13.00
	50	Light green	587653802	
	100	Red	587653803	
	200	Yellow	587653804	
	400	Blue/Light blue	587653805	
	800	Green	587653806	
	1,500	Orange	587653807	
	3,000	Pink	587653808	
	4,000	Black	n/a	
	Buff	White	n/a	
	Buff	Black	n/a	

	4" (101 MM) ITEM NO.	NET PRICE
	n/a	\$12.00
	542868283	
	542868284	
	842868285	
	542868286	
	542868287	
	542868288	
	542868289	
	n/a	
	n/a	
	n/a	

**POLISHING
PADS - WET**

⚙️ - Dry ■ - Continuous ▨ - Segmented ■ - Marble ■ - Porcelain
💧 - Wet ⚡ - Turbo ■ - Granite ■ - Engineered Stone



Fury™ Flex Pads. ■ ■ 💧

- Diamond-impregnated pads with a Velcro® connection

GRIT	BACKER COLOR	4" (101 MM) ITEM NO.	NET PRICE	5" (127 MM) ITEM NO.	NET PRICE
35	Purple	n/a	\$11.00	n/a	\$15.00
50	Light green	542862226		542863232	
100	Red	542862227		542863233	
200	Yellow	542862228		542863234	
400	Blue/Light blue	542862229		542863235	
800	Green	542862230		542863236	
1,500	Orange	542862231		542863237	
3,000	Pink	542862232		542863238	
4,000	Black	n/a		n/a	
Buff	White	542862233		542863239	
Buff	Black	542862234		542863240	



Pirahna™ Flex Pads. ■■■💧

- Benefits of a metal pad at an affordable price
- Hot press resin creates a denser resin for better diamond retention
- Longer life and a brilliant polish

	GRIT	BACKER COLOR	3" (76 MM) ITEM NO.	NET PRICE	4" (101 MM) ITEM NO.	NET PRICE	5" (127 MM) ITEM NO.	NET PRICE
	35	Purple	n/a	\$9.00	542867120	\$10.00	n/a	\$14.00
	50	Light green	542867380		542867121		542867387	
	100	Red	542867281		542867122		542867388	
	200	Yellow	542867382		542867123		542867389	
	400	Light blue	542867383		542867124		542867390	
	800	Green	542867384		542867125		542867391	
	1,500	Orange	542867385		542867126		542867392	
	3,000	Pink	542867386		542867127		542867393	
	4,000	Black	n/a		n/a		n/a	
	Buff	White	n/a		n/a		n/a	
	Buff	Black	n/a	n/a	n/a			

POLISHING PADS - WET

☀ - Dry ■ - Continuous ▨ - Segmented ■ - Marble ■ - Porcelain
 💧 - Wet ⚙ - Turbo ■ - Granite ■ - Engineered Stone



Rambo™ Select Pads. ■ ■ 💧

- Diamond-impregnated pads with a Velcro® connection

GRIT	BACKER COLOR	4" (101MM) ITEM NO.	NET PRICE
35	Purple	n/a	\$13.00
50	Light green	542865252	
100	Red	542865253	
200	Yellow	542865254	
400	Blue/Light blue	542865255	
800	Green	542865256	
1,500	Orange	542865257	
3,000	Pink	542865258	
4,000	Black	n/a	
Buff	White	542865259	
Buff	Black	n/a	

Diamax Cyclone™ Ultra Wet. ■ ■ 💧

- Resin and heavy diamond formula, the pads have a longer life and minimize polishing time

4" (101 MM) ITEM NO.	NET PRICE	5" (127 MM) ITEM NO.	NET PRICE
n/a	\$15.00	n/a	\$26.00
542867045		542867308	
542867046		542867309	
542867047		542867310	
542867048		542867311	
542867049		542867312	
542867050		542867313	
542867051		542867314	
542867052		542867315	
n/a		n/a	
n/a	n/a	n/a	



Gator Flex™ Pads. ■■■💧

- Performs well at a reasonable price

Magnum Flex™ Pads. ■■■💧

- Diamond-impregnated, 3 mm thick Velcro® connection
- 5" pad available

GRIT	BACKER COLOR	4" (101 MM) ITEM NO.	NET PRICE
35	Purple	n/a	\$8.00
50	Light green	542862195	
100	Red	542862196	
200	Yellow	542862197	
400	Light blue	542862198	
800	Green	542862199	
1,500	Orange	542862200	
3,000	Pink	542862201	
4,000	Black	n/a	
Buff	White	542862202	
Buff	Black	542862203	

BACKER COLOR	3" (76 MM) ITEM NO.	NET PRICE	4" (101 MM) ITEM NO.	NET PRICE
	n/a	\$11.00	n/a	\$14.00
Light green	542862237		542862246	
Off white	542862238		542862247	
Yellow	542862239		542862248	
Light blue	542862240		542862249	
Orange	542862241		542862250	
Dark green	542862242		542862251	
Red	542862243		542862252	
	n/a		n/a	
White	542862245		542862254	
Black	542862244		542862253	

Micro Buffing Pads.

- New and improved micronized diamonds for long life and superior shine

4" (101 MM) ITEM NO.	FRONT COLOR	NET PRICE
542868182	White	\$26.00
542868183	Black	



POLISHING PADS - DRY

☀ - Dry
 ■ - Continuous
 ▨ - Segmented
 ■ - Marble
 ■ - Porcelain
💧 - Wet
 ⌚ - Turbo
 ■ - Granite
 ■ - Engineered Stone



Magnum™ Dry Pads. ■ ■ ■ ☀

- Used to polish granite, use slightly wet for best results. Excellent polish even on difficult stone
- Used for ogees/inside radius

GRIT	BACKER COLOR	4" (101 MM) ITEM NO.	NET PRICE
60	Teal	542860050	\$34.00
80	Black	542860051	
200	Olive	542860052	
400	Orange	542860053	
800	White	542860054	
1,500	Blue	542860055	
3,000	Yellow	542860056	
6,000	Red	542860057*	
8,000	Brown	542860058*	
Buff	White	n/a	
Buff	Black	n/a	

*excellent when used slightly wet

Magnum™ II Dry Pads. ■ ■ ■ ☀

- Flexible when used for ogees/inside radius polishing
- For fast results when using dry, pads should be opened 'wet'

GRIT	BACKER COLOR	4" (101 MM) ITEM NO.	NET PRICE
50	Light green	542863287	\$20.00
100	Red	542863288	
200	Yellow	542863289	
400	Light blue	542863290	
800	Green	542863291	
1,500	Orange	542863292	
3,000	Pink	542863293	
5,000	Tan	542863294	
8,000	Light Pink	542863295	

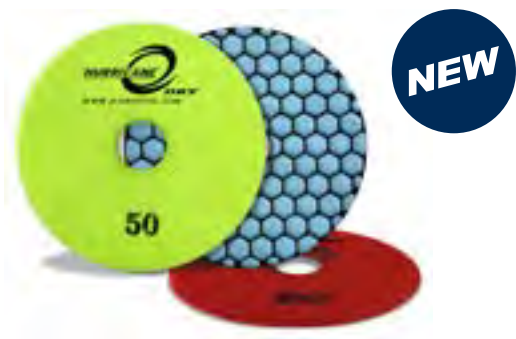

Diamax Hurricane™ Dry Pads. ■ ■ ■ ⚙️
Limestone

- Great cost/performance ratio

Fury™ Dry Pads. ■ ■ ■ ⚙️ **Limestone**

- Diamond-impregnated
- Best selling dry pads

GRIT	BACKER COLOR	4" (101 MM) ITEM NO.	NET PRICE
50	Light green	542779168	\$18.00
100	Red	542779169	
200	Yellow	542779170	
400	Light blue	542779171	
800	Green	542779172	
1,500	Orange	542779173	
3,000	Pink	542779174	
Buff	White	542779175	
Buff	Black	n/a	

4" (101 MM) ITEM NO.	NET PRICE
542862217	\$18.00
542862218	
542862219	
542862220	
542862221	
542862222	
542862223	
542862224	
542862225	

POLISHING PADS - 3 STEP

- ☀ - Dry
- - Continuous
- ▨ - Segmented
- - Marble
- - Porcelain
- 💧 - Wet
- ⚙ - Turbo
- - Granite
- - Engineered Stone

Rambo™ Trifecta Pads. ■ ■ 💧 ☀

- Step 1 is off the saw and steps 2 and 3 are off the CNC machine

STEPS	4" (101 MM) ITEM NO.	NET PRICE
Step 1	542868084	\$33.00
Step 2	542868085	
Step 3	542868086	



3-Step Rambo™ Pads. ■ ■ 💧 ☀

- Leaves a good finish when used wet or dry
- White to reduce marking on engineered stone

STEPS	4" (101 MM) ITEM NO.	NET PRICE
Step 1	542779339	\$27.00
Step 2	542779340	
Step 3	542779341	

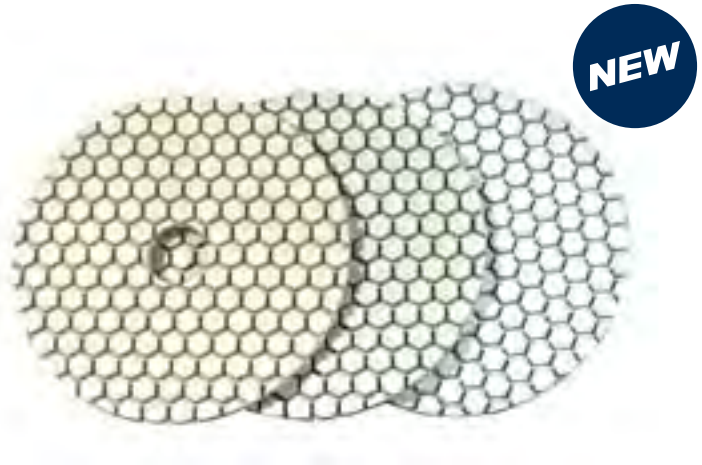

Magnum™ 3-Step Pads. ■ ■ 💧

- Engineered for long life and a bright polish
- Must be opened (diamonds exposed) before use
- Pads are copper phenolic and turn a green color when opened

STEPS	4" (101 MM) ITEM NO.	NET PRICE
1X/Aggressive	542868377	\$21.00
Step 1	542868178	
Step 2	542868179	
Step 3	542868180	





Flex Pads. ■ Limestone ⚙️

- Made of resin and diamond-electroplated with Velcro® mountings

GRIT	BACKER COLOR	4" (101 MM) ITEM NO.	NET PRICE
60	Green	543002963	\$57.00
120	Black	543002954	\$52.00
220	Red	543002945	\$36.00
400	Yellow	543002936	\$36.00
800	White	543002927	\$23.00
1,500	Blue	543003124	\$23.00

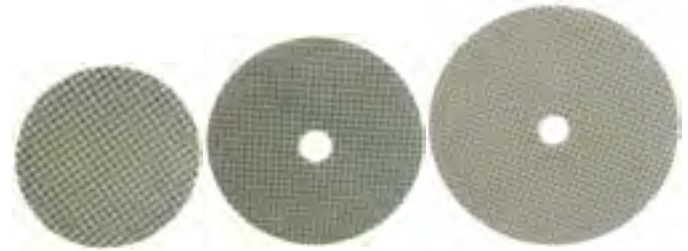

Electroplated Pads. ■ Limestone ⚙️

- Used for various applications on marble or limestone
- Velcro® backs are also available in 3", 5", 7" or 10"

GRIT	4" (101 MM) ITEM NO.	NET PRICE
50	542861393	\$26.00
70	542861394	
120	542861395	\$21.00
220	542861396	
400	542861397	
600	542861398	

POLISHING PADS - ENGINEERED STONE

6-Step Engineered Pads. ■💧

- Great finish in 6 steps
- Designed to reduce marking on stone

STEPS	4" (101 MM) ITEM NO.	NET PRICE
1	542870049	\$19.00
2	542870050	
3	542870051	
4	542870052	
5	542870053	
Buff	542870054	



HAND PADS

☀ - Dry ■ - Continuous ▨ - Segmented ■ - Marble ■ - Porcelain
💧 - Wet 🔄 - Turbo ■ - Granite ■ - Engineered Stone

Hand Pads. ■ ■ ■ 💧

- Flexible diamond pads with foam backings for comfort

DESCRIPTION INCHES (MM)	GRIT	COLOR	ITEM NUMBER	NET PRICE
4 x 2-1/2 (100 x 65)	50	Green	543003228	\$14.00
	120	Black	543003232	
	220	Red	543003236	
	400	Yellow	543003240	
	600	Orange	543003244	
	800	White	543003248	
	1800	Blue	543003252	

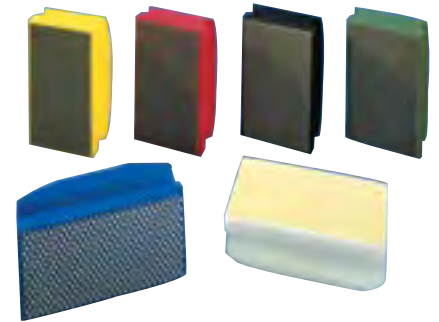

Electroplated Hand Pads. ■ ■ ■ 💧

- Diamond pads with foam backings, for use on granite and marble
- Must be used wet

DESCRIPTION INCHES (MM)	GRIT	COLOR	ITEM NUMBER	NET PRICE
4 x 2-1/3 (90 x 55)	60	Green	542866841	\$18.00
	100	Black	542866842	
	200	Red	542866843	
	400	Yellow	542866844	
	800	White	542866845	
	1500	Gray	542866846	
	3000	Blue	542866847	



Foam Pad Palm Holder.

- Velcro®. Use by hand with any pad

DIAMETER INCHES (MM)	ITEM NUMBER	NET PRICE
3 (90)	542862206	\$16.00
4 (100)	542862207	\$17.00



Razor™ Vitrified Pads. ■ ■ ●

- Great for removing chatter marks from saw jets
- Eliminates chances of haze or fogline results on stone
- Best choice for light shaping, removal of saw marks and waviness
- Won SFA - Stone Fabricators Alliance Olympics
- Must be used wet

GRIT	DIAMETER INCHES (MM)	BACK COLOR	ITEM NUMBER	NET PRICE
50	4 (101)	Green	542866976	\$33.00
100		Black	542866977	
200		Red	542866978	



Vulcan Metal Flex Pads. ■ ■ ●

- Can be used in place of vitrified or rigid copper pads as well as zero-tolerance pads and/or sink wheels

GRIT	DIAMETER INCHES (MM)	BACK COLOR	ITEM NUMBER	NET PRICE
30	4 (101)	Purple	542867150	\$36.00
50		Light green	542867151	
100		Red	542867152	
200		Yellow	542867153	
400		Blue	542867154	



Quick Change Flat Polishing Discs. ■ ■ ●

- Perfect for final polishing or scratch removal on flat granite surfaces
- Rigid back-up pad that also eliminates waviness
- Tapered edges allow it to be used close to corners and are great for seams creating an even, smooth surface
- Must be used wet. Also available in 5"

GRIT	DIAMETER INCHES (MM)	ITEM NUMBER	NET PRICE
50	3 (75)	542861300	\$37.00
70*	3 (75)	542861301	\$65.00
100	3 (75)	542861302	\$37.00
200	3 (75)	542861303	
400	3 (75)	542861304	
800	3 (75)	542861305	
1,500	3 (75)	542861306	
3,000	3 (75)	542861307	
Buff	3 (75)	542861308	
Backer Pad 5/8"-11	3 (75)	542861309	



*Copper



Nicolai Abracadabra Supreme. ■ ■ 💧

- High quality shine on granite and engineered stone
- Long life makes them economical to buy
- Can be used on natural stone and engineered for flat, bullnose and bevel edges

GRIT	BACKER COLOR	5" (125 MM) ITEM NO.	NET PRICE	6" (150 MM) ITEM NO.	NET PRICE
60/80	White	587213026	\$129.00	587213035	\$149.00
100		587213027		587213036	
200		587213028		587213037	
400		587213029		587213038	
600		587213030		587213039	
800		587213031		587213040	
1500		587213032		587213041	
3500		587213033		587213042	
5000		587213034		587213043	

Turbo Diamond Pre-Cut. ■ ■ 💧

- Aggressive, long life wheel
- For use with GlossFire™ polishing wheels and flat edge machines

DIAMETER	ITEM NO.	NET PRICE
5 (125)	542863176	\$215.00

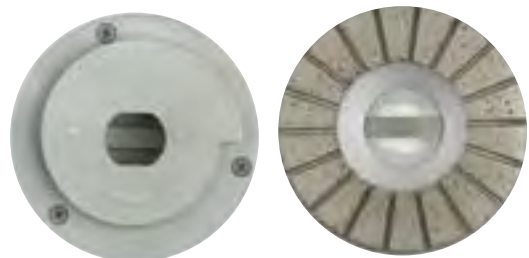

Magnum™ 5-Step Polishing System. ■ ■ ●

- Used on C-type machines for radius and flat edge work
- Resin pads are now thicker and feature an increased diamond concentration

APPLICATION	ITEM NO.	NET PRICE
Step 1, Metal (Graphite)	542862063	\$133.00
Step 2, Metal	542862064	\$133.00
Step 3, Resin	542863607	\$34.00
Step 4, Resin	542862066	\$21.00
Step 5, Resin	542862067	\$21.00
Rigid Snail Lock Backer (8mm)	542862205	\$12.00
Rigid Snail Lock Backer (15mm)	542862326	\$16.00



GlossFire-F™ Flat Edge Resin Wheels. ■ ■ ●

- Formerly Toro-F
- For use with C-Frame In-Line machinery
- Perfect for flat edges, snail lock backer

GRIT	COLOR	DIAMETER INCHES (MM)	ITEM NO.	NET PRICE
50	Green	4 (101)	542863116	\$38.00
100	Black		542863117	
200	Red		542863118	
500	Yellow		542863119	
1,000	White		542863120	
2,000	Blue		542863121	
Buff	Purple		542863122	



**GlossFire-F™ (Formerly Toro-F)
Resin Polishing Wheels.** ■ ■ ■ 💧

- Perfect for flat edges
- Works for flat, straight edge polishing only. Snail lock



GRIT	COLOR	5" (127 MM) ITEM NO.	NET PRICE	6" (150 MM) ITEM NO.	NET PRICE
30	Teal		\$54.00	542863067	\$65.00
50	Green	542863099		542863068	
100	Black	542863100		542863069	
200	Red	542863101		542863070	
500	Yellow	542863102		542863071	
1,000	White	542863103		542863072	
2,000	Blue	542863104		542863073	
Buff	Purple	542863105		542863074	

**GlossFire-F™ (Formerly Toro-F)
Vertical Copper Wheels.** ■ ■ ■ 💧

- Works for multi-head machines
- Flat edge only, snail lock



GRIT	5" (127 MM) ITEM NO.	NET PRICE	6" (150 MM) ITEM NO.	NET PRICE
30	542862324	\$143.00	542863662	\$164.00
50	542862325		542863663	
100	542860062		542863664	
200	542860063		542863665	
Chamfer Wheel	542866980	\$123.00	n/a	

GlossFire-B™ (Formerly Toro-B)
Multi-Edge Resin Polishing Wheels. ■■■

- Multiedge and bullnose
- Snail lock
- Works with any multihead machine



GRIT	COLOR	5" (127 MM) ITEM NO.	NET PRICE	6" (150 MM) ITEM NO.	NET PRICE
50	Green	542863651	\$82.00	542863577	\$92.00
100	Black	542863652		542863578	
200	Red	542863653		542863579	
500	Yellow	542863654		542863580	
1,000	White	542863655		542863581	
2,000	Blue	542863656		542863582	
Buff	Purple	542863657		542863583	

GlossFire-B™ (Formerly Toro-B)
Multi-Edge Copper Wheels. ■■■

- Multiedge and bullnose
- Snail lock
- Works with any multihead machine



GRIT	5" (127 MM) ITEM NO.	NET PRICE	6" (150 MM) ITEM NO.	NET PRICE
100	542863660	\$143.00	588798610	\$183.00
200	542863661		588798611	

Silicon Carbide Antiquing Brushes. ■ ■ 💧

- Used to achieve an antique look and are for use on polisher or radial arm machines
- Dual 5/8"-11 snail lock



GRIT	4" (101 MM) ITEM NO.	NET PRICE
24	542868364	\$26.00
36	542868365	
46	542868366	
60	542868367	
80	542868368	
120	542868369	
240	542868370	
320	542868371	
500	542868372	

ACCESSORY FOR SNAIL LOCK BRUSHES

BACKER PAD	MOUNT	4" (100 MM) ITEM NO.	NET PRICE
Aluminum with Rubber Damper	5/8"-11 Snail Lock	542867170	\$41.00

Diamond Bristle Brushes. ■ ■ 💧



GRIT	4" (100 MM) ITEM NO.	NET PRICE
36	542868447	\$59.00
46	542868448	
64	542868449	





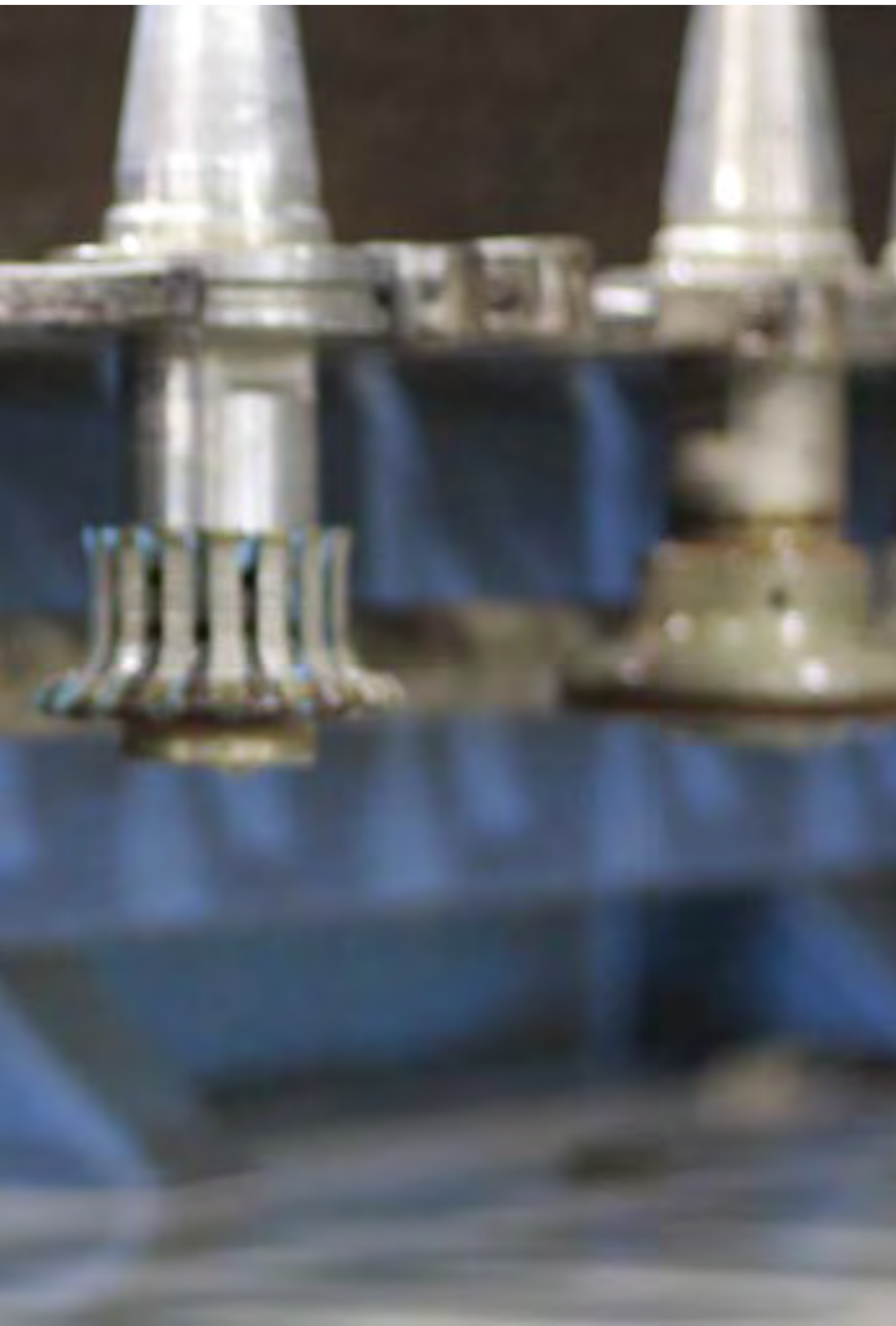

CNC FINGER BITS	62
CORE DRILL BITS	63
BREAKER WHEELS	65
MITRE SYSTEMS	68
CORNERBREAKERS	67
CNC X AND Y CALIBRATING/STUBBING WHEELS	68
CNC SHAPES	70
MAGNUM CNC TOOLS	78
SPECIAL TOOLS FOR SINK OPENING	80
ROUTER BITS	81
CNC WHEELS	82
CNC ENGRAVING MILLS	83
CNC ROUNDED HEAD MILLS	85
CNC BLADES	85
CNC ACCESSORIES	86

Rambo™ PDT CNC Finger Bits. ■ ■ ▬ 💧

- 6-segmented bit features patterned diamond technology, which results in consistent, fast cuts



SIZE INCHES (MM)	NO. OF SEGMENTS	BOND	COLOR	RPM	FEED RATE INCHES (MM)	ITEM NO.	NET PRICE
1 x 40 mm	5	Soft	Gray	5,000	12-18 (300-450)	542867458	\$112.00

Segmented CNC Finger Bits

- Made to cut fast and have a wide application range
- Add a segment to plunge cut for \$15.00

DIAMETER (LENGTH) MM	NO. OF SEGMENTS	MATERIAL	COLOR	RPM	FEED RATE INCHES (MM)	ITEM NO.	NET PRICE
23 (40)	5	Hard & Medium Granite	Yellow	4,300-5,200	10-19 (250-500)	542860506	\$112.00
23 (50)	5					542860509	\$133.00
23 (60)	5					542860511	\$153.00
23 (70)	5					542860514	\$153.00
23 (40)	6	All Granite & Eng. Stone	Yellow			542866859	\$123.00
23 (40)	5	Soft & Medium Granite	Blue			542860504	\$112.00
23 (40)	5					542860505	\$112.00
23 (50)	5					542860507	\$123.00
23 (50)	5					542860508	\$123.00
23 (60)	5					542860510	\$133.00
23 (70)	5					542860513	\$153.00
23 (40)	5	Eng. Stone	White			542863061	\$123.00
23 (40)	5	All Granite	Blue	5,500-6,000	12 (300)	542779080*	\$174.00
18 (40)	4	All Granite	Yellow	5,000-5,500	13-19 (300-500)	542865001	\$133.00
23 (40)	4	Eng. Stone	Red	5,800-6,200	18-20 (450-500)	542865388	\$71.00
23 (50)	4			5,800-6,200	14-16 (350-400)	542866769	\$81.00
23 (40)	5			5,800-5,500	12-16 (300-400)	542865389	\$81.00
23 (50)	5			5,800-6,200	14-16 (350-400)	542866770	\$92.00
23 (40)	5		Purple	4,800-5,200	10-12 (250-300)	542865376	\$81.00

The "506"



"Big Red"



Other lengths available. *Great for Park CNC.

Conditioning Sticks.

- Re-expose diamonds on CNC tools
- Recommended for wet use only

GRIT	ITEM NO.	NET PRICE
Fine	542779313	\$21.00
Coarse	542779314	\$21.00



Thinwall Core Bits. ■ ■ ■

- Fast-cutting bits

DIAMETER INCHES (MM)	LENGTH INCHES (MM)	RPM	FEED RATE INCHES (MM)	ITEM NO.	NET PRICE
1-1/4 (32)	2 (50)	2,400	1-1/2-2 (40-50)	542863310	\$102.00
1-3/8 (35)		2,200	2 (50)	542863311	\$112.00
1-1/2 (40)				542863312	\$123.00
1-3/8 (35)*	2-3/4 (70)	2,500-3,000	2.4 - 4	542861365	\$123.00

*electroplated



Core Bits. ■ ■ ■ 1/2 Gas Connection

- Long-lasting core bits
- Other sizes available

DIAMETER INCHES (MM)	LENGTH INCHES (MM)	RPM	FEED RATE INCHES/MIN	ITEM NO.	NET PRICE
3/4 (20)	2-3/4 (70)	2,800-3,500	2.4 - 4	542860524	\$74.00
1-1/4 (32)		2,500-3,000		542860527	\$88.00
1-3/8 (35)				542860528	\$92.00
1-1/2 (40)		542860529		\$102.00	



Short-Style Core Bits. ■ ■ ■ 1/2 Gas Connection

- Shorter core bits perfect for cutting thinner materials

DIAMETER INCHES (MM)	LENGTH INCHES (MM)	RPM	FEED RATE INCHES/MIN	ITEM NO.	NET PRICE
1-1/4 (32)	1-1/2 (40)	2,500-3,000	2.4 - 4	542861381	\$81.00
1-3/8 (35)				542860080	\$81.00



CNC Non-Coring Bits. ■ ■ 💧 ▬ 1/2 Gas Connection

- Perfect for making small diameter holes

DIAMETER INCHES (MM)	LENGTH INCHES (MM)	ITEM NO.	NET PRICE
.197 (5)	1-3/8 (35)	543015211	\$60.00
.237 (6)	2-3/20 (55)	543015213	\$60.00
NEW 1/4 (6.37)	2 (50)	542868335	\$52.00
.275 (7)	2-3/20 (55)	543015215	\$62.00
.315 (8)		543015217	\$64.00
.394 (10)		543015221	\$64.00
.433 (11)	2-1/2 (65)	543015223	\$66.00
.472 (12)		543015225	\$66.00



Accessories.

NAME	CONNECTION	ITEM NO.	NET PRICE
Female thread	1/2 Gas to 5/8"-11	542860081	\$58.00
Male thread	1/2 Gas to 5/8"-11	542860082	\$35.00
1/2 gas collet		542860083	\$74.00
Clamp		542861452	\$48.00
Pliers		542861451	\$41.00



Twister Pre-Wheels. 

- Multiple blade wheel available in both 35 mm and 22 mm arbors
- Typical shapes are shown below; half-sizes and custom shapes are available
- 4,800 - 5,000 RPMs
- 1,200 - 2,000 mm/min feed rate

DESCRIPTION	ITEM NO.	NET PRICE
9-D150	542868067	\$206.00
8-D140	542867265	\$196.00
7-D130	542867266	\$185.00
6-D120	542867267	\$165.00
5-D110	542867268	\$144.00
4-D100	542867269	\$134.00
3-D90	542867270	\$124.00
NEW 2-1/2-D85	542868455	\$118.00
2-D80	542867271	\$113.00
1-D70	542867272	\$93.00
Spacer (aluminum)	542867273	\$10.00
Blade lock	542867274	\$10.00
Sleeve for 7 blade assembly	542867275	\$62.00
Sleeve for 8 blade assembly	542867276	\$62.00



Typical shapes below. Possible shapes are unlimited.

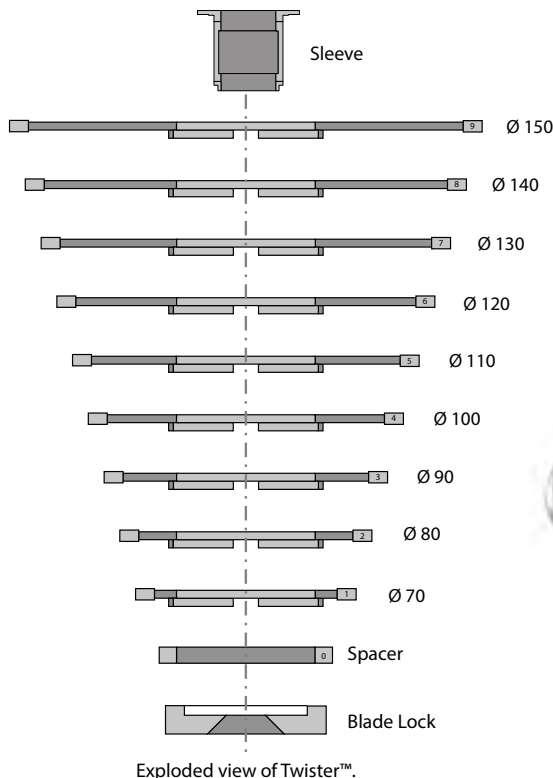
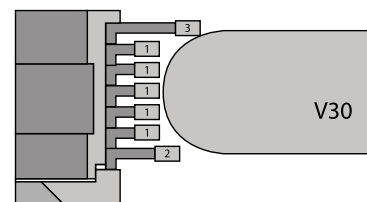
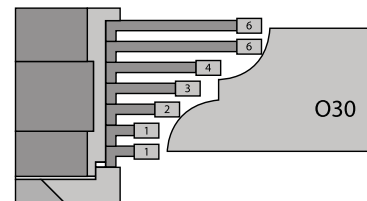
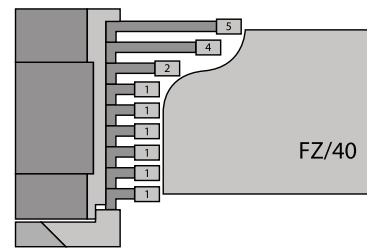
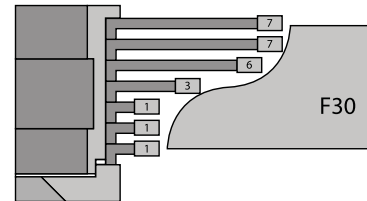
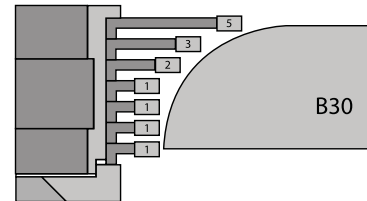
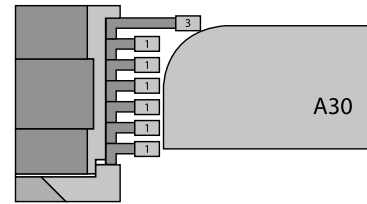

Spacer Blade Lock
(Spacer not required on most configurations.)



LOCKED MITER SYSTEM

- ⚙️ - Dry
- - Continuous
- ▨ - Segmented
- - Marble
- - Porcelain
- 💧 - Wet
- 🔄 - Turbo
- - Granite
- - Engineered Stone

Mitre - Male Wheel.

- Max diameter is 120 mm
- Call for price

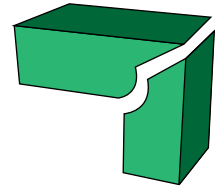

STEP	TYPE	SLAB MM	RPM	FEED RATE MM/MIN	ITEM NO.
1	Segmented G1	20	4,300 - 4,800	600 - 1,000	542868459
2	Electroplated D1				542868460
1	Segmented G1	30			542868230
2	Electroplated D1				542868231



Mitre - Female Wheel.

- Max diameter is 120 mm
- Call for price

STEP	TYPE	SLAB MM	RPM	FEED RATE MM/MIN	ITEM NO.
1	Segmented G1	20	4,300 - 4,800	600 - 1,000	542868459
2	Electroplated D1				542868458
1	Segmented G1	30			542868228
2	Electroplated D1				542868229



45° MITER SYSTEM

Cornerbreaker.

- Min diameter is 60 mm / Max diameter is 120 mm
- Call for price

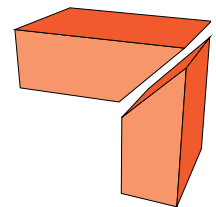

STEP	TYPE	SLAB MM	RPM	FEED RATE MM/MIN	ITEM NO.
0	Multiblade	30	4,800 - 5,000	1,200 - 2,000	542868459



Segmented Cornerbreaker.

- Min diameter is 60 mm / Max diameter is 146 mm
- Call for price

STEP	TYPE	SLAB MM	RPM	FEED RATE MM/MIN	ITEM NO.
1	Segmented G1	30	4,500	500 - 700	542860535



*For Marble use the coarser grit

Electroplated Cornerbreaker.

- Min diameter is 60 mm / Max diameter is 120 mm
- Call for price

STEP	TYPE	SLAB MM	RPM	FEED RATE MM/MIN	ITEM NO.
2	Electroplated D2	30	4,500	800 - 1,000	588174701
2	Electroplated D2	30	4,500	800 - 1,000	542868277*

*For Marble use the coarser grit



SEGMENTED

Segmented Tornado Cornerbreaker - Profile Y.

- Ultra high speed stock removal
- Min diameter is 65 mm / Max diameter is 126 mm
- Call for price



DESCRIPTION	TYPE/POSITION	RPM	FEED RATE MM/MIN	ITEM NO.
Y30 - MB7	Segmented / PO	4,800 - 5,000	1,200 - 2,000	588240201
Y30 - MB5				
Y30 - MB8				

Segmented Tornado Cornerbreaker - Profile X.

- Ultra high speed stock removal
- Min diameter is 65 mm / Max diameter is 92 mm
- Call for price



DESCRIPTION	TYPE/POSITION	RPM	FEED RATE MM/MIN	ITEM NO.
X40 - MB9	Segmented / G1	4,800 - 5,000	1,200 - 2,000	587224936
X30 - MB7				



Pre-Cutting Wheel – Double Corner. 💧 ▤

- Used to break both top and bottom edges of the slab at the same time

DIAMETER INCHES (MM)	SLAB THICKNESS	RPM	FEED RATE INCHES (MM)	ITEM NO.	NET PRICE
3-3/8 (85)	30	4,500	30-43 (750-1,100)	542860532	\$603.00
3-3/4 (95)	40	4,500	28-36 (700-1,000)	542860533	\$644.00



Breaking Pre-Cutting Wheel – Single Corner. 💧 ▤

- Perfect for breaking corners on one side

DIAMETER INCHES (MM)	SLAB THICKNESS	RPM	FEED RATE INCHES (MM)	ITEM NO.	NET PRICE
4-3/8 (11)	20/30	4,500	24-35 (600-900)	542863313*	\$443.00
5 (125)	30		20-28 (500-700)	542860535	\$536.00
5-3/4 (145)	40		18-26 (450-650)	542860536	\$742.00

* FAST CUTTING



DB Zero Pre-Cutting Wheel. 💧 ▤

- Premium wheel for use on all types of stone
- Ultra high speed pre-cutting breaker

DIAMETER INCHES (MM)	HEIGHT	RPM	FEED RATE INCHES (MM)	REMOVAL RATE INCHES (MM)	ITEM NO.	NET PRICE
3 (80)	45	4,500-5,000	200 (5,000)	.032 (.8)	542867194	\$473.00



Fury™ Zero Pre-Cutting Wheel. 💧 ▤

- Economical, pre-cutting wheel for all types of stone

DIAMETER INCHES (MM)	HEIGHT	RPM	FEED RATE INCHES (MM)	REMOVAL RATE INCHES (MM)	ITEM NO.	NET PRICE
3 (80)	35	4,500	100 (2,500)	.032 (.8)	542868052	\$308.00



Calibreaker Wheel. 💧 ▤

- Enables operator to calibrate and break the edge in one step
- It is available with a bevel or radius edge
- Calibrating wheel and breaking wheel sold separately

DESCRIPTION	ITEM NO.	NET PRICE
Calibrating Wheel	542779040	\$215.00
Bevel Wheel	542779042	\$249.00
Radius Wheel	542779046	\$339.00



Calibrating Wheel



Radius Wheel Electroplated



Bevel Wheel Electroplated



Calibrating/Stubbing Wheels. 🏠

- Ideal for grinding away a layer of stone to achieve a consistent slab thickness

DIAMETER INCHES (MM)	SEGMENT HEIGHT	RPM	FEED RATE INCHES (MM)	REMOVAL RATE INCHES (MM)	ITEM NO.	NET PRICE
3-3/8 (85)	20	4,000-4,200	16-24 (400-600)	1-6 (25-152)	542861057	\$340.00
4 (100)		4,000-4,100			542863243	\$386.00
6 (150)					542861061	\$587.00
3-3/8 (85)		542862334*			\$330.00	

* for marble



Marble

Fury™ Grinding and Calibrating Wheels. 🏠

- The Fury™ line is a more economical option when you need to remove a layer of stone to achieve a perfectly calibrated slab

DIAMETER INCHES (MM)	SEGMENT HEIGHT	RPM	FEED RATE INCHES (MM)	REMOVAL RATE INCHES (MM)	ITEM NO.	NET PRICE
3-3/8 (85)	20	4,300-4,500	16-24 (400-600)	1-6 (25-152)	542863626	\$205.00
4 (100)		4,000-4,200			542863678	\$256.00
5 (125)		4,000-4,100			542863680	\$277.00
6 (150)					542863681	\$339.00
7 (180)					542863682	\$359.00



Heavy-Duty Recess Wheel. 🏠

- Longer wheel life for calibrating slabs

DIAMETER INCHES (MM)	SLAB THICKNESS	RPM	FEED RATE INCHES (MM)	ITEM NO.	NET PRICE
3-7/8 (92)	30	4,500	16-24 (400-600)	542867228	\$349.00



Small Diameter Calibrating/Stubbing Wheels. 🏠

- Performs just like the larger version, just for smaller diameters

DIAMETER INCHES (MM)	SEGMENT HEIGHT	RPM	FEED RATE INCHES (MM)	REMOVAL RATE INCHES (MM)	ITEM NO.	NET PRICE
2 (50)	20	4,300-4,500	16-24 (400-600)	1-6 (25-152)	542863242	\$226.00



Shown together

Accessories.

DESCRIPTION	ITEM NO.	NET PRICE
1/2 Gas Adapter DM10+2 *	542863244	\$77.00
1/2 Gas Adapter DM50+3	542861196	\$130.00

* ONLY FOR SMALL DIAMETER CALIBRATING/STUBBING WHEEL



1/2 Gas Adapter



Call to Order: 1.800.461.9589

Linebuster. ■ ■ 💧

- Resin diamond wheels are to be used with "T", "Z" and other profiles with flat edges
- Used after metal bond wheels and before Xbrite™ polishing wheels
- Spindle oscillation is recommended
- Other sizes available, call for more information



DIAMETER INCHES (MM)	ARBOR INCHES (MM)	HEIGHT INCHES (MM)	RPM	FEED RATE INCHES (MM)	ITEM NO.	NET PRICE
3 (78)	1-2/5 (35)	1-2/5 (35)	3,000	32 (800)	542863389	\$294.00
3 (78)	1-2/5 (35)	2-1/5 (55)	3,000	32 (800)	542863391	\$330.00

Oscillation:

1mm UP
 1mm DOWN

Nicolai 20 Series CNC Tools.



- Widest selection of shapes available and always developing custom profiles
- Call for prices
- M3PRO™ SUPERFAST technology generates lower decibels
- All metal wheels are made with 4.5 mm thick bond and are suitable to be redressed 2 or 3 times
- Most CNC tooling runs with polishing side down (FD)
- Polish side up tooling available also (FU)



20 SERIES • 1/2 GAS CONNECTION								
POSITION	RPM	FEED RATE MM	REMOVAL RATE (MM)	Z45	T30r3	A30r3 FU	A30r3	A30r6
P1	4,300-4,7000	1,000-3,000	to shape	542863375	542863371	542863357	542863364	542867281
P3	4,300-4,7000	1,000-3,000	0.5	542863379	542863372	542863358	542863365	542867282
P4	4,500-4,800	1,200-3,000	0.2	542863380	542863373	542863359	542863366	542867283
P5	4,500-4,800	1,200-2,000	0.1	542863381	542863374	542863360	542863367	542867284
P6	2,200-2,500	800	0-0.5	542863382	542863376	542863361	542863368	542867285
P7	2,200-2,500	800	0-0.5	542863383	542863377	542863362	542863369	542867286
P8	2,200-2,500	800	0-0.5	542863384	542863378	542863363	542863370	542867287

FU = Face Up

20 SERIES • 1/2 GAS CONNECTION					
POSITION	RPM	FEED RATE MM	REMOVAL RATE (MM)	T30r5	A30r5
P1	4,300-4,7000	1,000-3,000	to shape	542868160	501107701
P3	4,300-4,7000	1,000-3,000	0.5	542868161	501107703
P4	4,500-4,800	1,200-3,000	0.2	542868162	501107704
P5	4,500-4,800	1,200-2,000	0.1	542868163	501107705
P6	2,200-2,500	800	0-0.5	587224919	501107706
P7	2,200-2,500	800	0-0.5	587224920	-
P8	2,200-2,500	800	0-0.5	587224921	-

Nicolai 40 Series CNC Tools.



- Widest selection of shapes available and always developing custom profiles
- Call for prices
- M3PRO™ SUPERFAST technology generates lower decibels
- All metal wheels are made with 4.5 mm thick bond and are suitable to be redressed 2 or 3 times



40 SERIES						
POSITION	RPM	FEED RATE MM	REMOVAL RATE (MM)	Z45	A30r5	T30r5
P1	5,200	800-1,000	to profile	542867296	542868108	542863343
P3	5,200	1,000-1,200	0.3	542867297	542868109	542863344
P4	5,200	1,000-1,500	0.15	542867298	542868110	542863345
P5	5,200	1,000-1,500	0.1	542867299	542868111	542863346
P6	2,700	700	.0005-.0002	542867300	542861112	542863347
P7	2,700	700	.0005-.0002	542867301	542861113	542863348
P8	2,700	700	.0005-.0002	542867302	542861114	542863349



A	Small diameter adapter	542862215	\$75
---	------------------------	-----------	------

For 40 Diameter Series

Nicolai 60 Series CNC Tools.

A20 (radius 10) Small Radius - Outside diameter of 85 mm

A30r3 Small Radius - Outside diameter of 95 mm

A30 (radius 5) Small Radius - Outside diameter of 95 mm

A30 (radius 6) Small Radius - Outside diameter of 95 mm

A30 (radius 10) Small Radius - Outside diameter of 95 mm

A30 (radius 15) Half Bullnose - Outside diameter of 95 mm

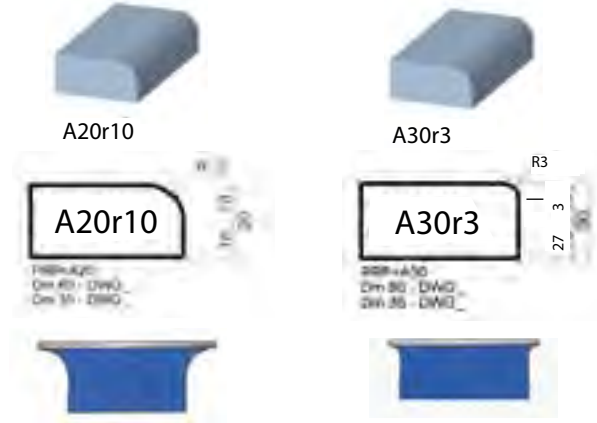

POSITION	RPM	FEED RATE MM	REMOVAL RATE MM	A20 (RADIUS 10) SMALL RADIUS	A30 (RADIUS 3) SMALL RADIUS
P1	4,300-4,7000	1,000-3,000	to shape	542865072	542865080
P3	4,300-4,7000	1,000-3,000	0.5	542865073	542865081
P4	4,500-4,800	1,200-3,000	0.2	542865074	542865082
P5	4,500-4,800	1,200-2,000	0.1	542865075	542865083
P6	2,200-2,500	800	0-0.5	542863421	542865068
P7	2,200-2,500	800	0-0.5	542863422	542865069
P8	2,200-2,500	800	0-0.5	542863423	542865070

B30 (radius 30) Large Radius - Outside diameter of 125 mm

E30 Bevel - Outside diameter of 105 mm

F20 Ogee - Outside diameter of 100 mm

F30 Ogee - Outside diameter of 120 mm

F20 + 10 (FZ30) Ogee Flat - Outside diameter of 100 mm

F20 + 20 (FZ40) Ogee Flat - Outside diameter of 100 mm

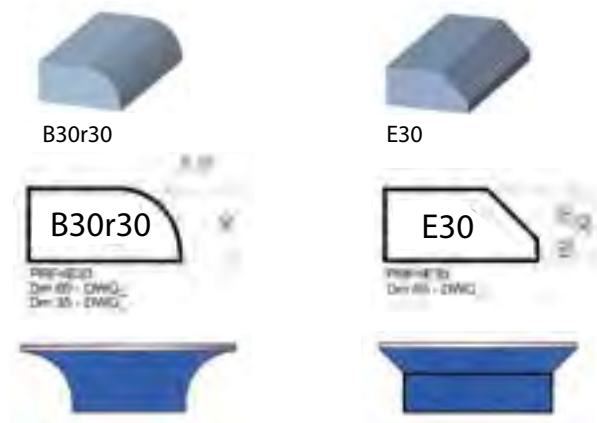

POSITION	RPM	FEED RATE MM	REMOVAL RATE MM	B30 (RADIUS 30) HALF BULLNOSE	E30 BEVEL
P1	4,300-4,7000	1,000-3,000	to shape	542865096	542866646
P3	4,300-4,7000	1,000-3,000	0.5	542865097	542866647
P4	4,500-4,800	1,200-3,000	0.2	542865098	542866648
P5	4,500-4,800	1,200-2,000	0.1	542865099	542866649
P6	2,200-2,500	800	0-0.5	542863439	542863451
P7	2,200-2,500	800	0-0.5	542863440	542863452
P8	2,200-2,500	800	0-0.5	542863441	542863453

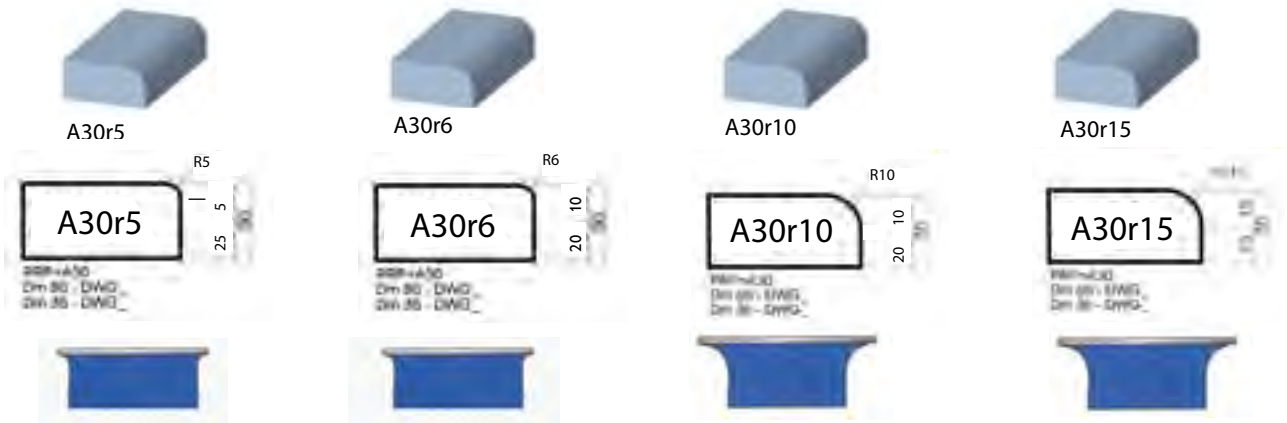

A30 (RADIUS 5) SMALL RADIUS	A30 (RADIUS 6) SMALL RADIUS	A30 (RADIUS 10) SMALL RADIUS	A30 (RADIUS 15) HALF BULLNOSE
542865084	542866642	542865088	542865076
542865085	542866643	542865089	542865077
542865086	542866644	542865090	542865078
542865087	542866645	542865091	542865079
542863427	542863430	542865404	542863424
542863428	542863431	542865405	542863425
542863429	542863432	542865406	542863426

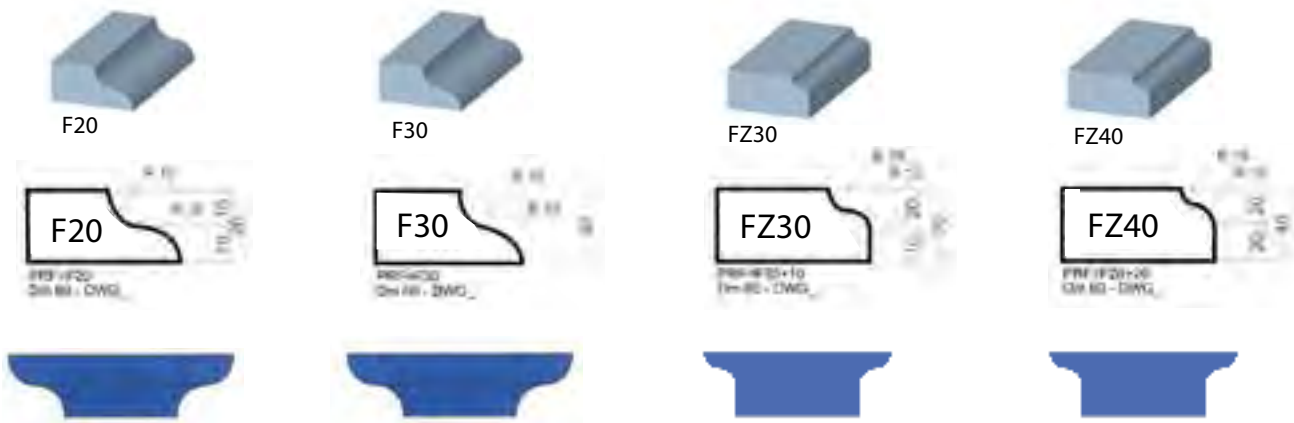

F20 OGEE	F30 OGEE	F20 + 10 (FZ30) OGEE FLAT	F20 + 20 (FZ40) OGEE FLAT
542865104	542865108	542865112	542866650
542865105	542865109	542865113	542866651
542865106	542865110	542865114	542866652
542865107	542865111	542865115	542866653
542863460	542863469	542863463	542863466
542863461	542863470	542863464	542863467
542863462	542863471	542863465	542863468

Nicolai 60 Series CNC Tools.

H30 Dupont - Outside diameter of 110 mm

L20 Cove - Outside diameter of 90 mm

L30 Cove - Outside diameter of 110 mm

LV30 Cove Bullnose - Outside diameter of 100 mm

O30 Cove over Dupont - Outside diameter of 110 mm

T30 (radius 3) Eased Edge - Outside diameter of 95 mm

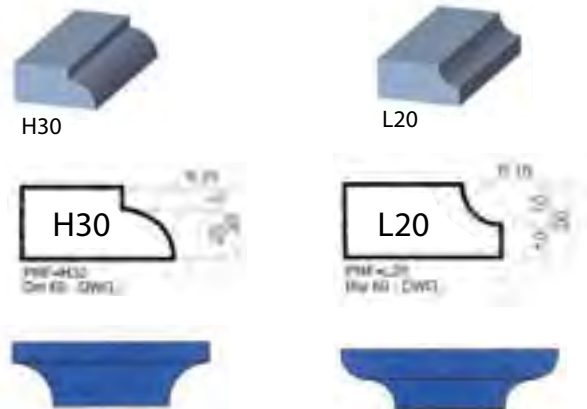

POSITION	RPM	FEED RATE MM	REMOVAL RATE MM	H30 DUPONT	L20 COVE
P1	4,300-4,7000	1,000-3,000	to shape	542865132	542865136
P3	4,300-4,7000	1,000-3,000	0.5	542865133	542864137
P4	4,500-4,800	1,200-3,000	0.2	542865134	542865138
P5	4,500-4,800	1,200-2,000	0.1	542865135	542865139
P6	2,200-2,500	800	0-0.5	542863478	542865419
P7	2,200-2,500	800	0-0.5	542863479	542865420
P8	2,200-2,500	800	0-0.5	542863480	542865421

T30 (radius 5) Eased Edge - Outside diameter of 75 mm

T30 (radius 6) Eased Edge - Outside diameter of 75 mm

V20 Bullnose - Outside diameter of 60 mm

V30 Bullnose - Outside diameter of 60 mm

V40 Bullnose - Outside diameter of 105 mm

V60 Bullnose - Outside diameter of 130 mm



POSITION	RPM	FEED RATE MM	REMOVAL RATE MM	T30 (RADIUS 5) EASED EDGE	T30 (RADIUS 6) EASED EDGE
P1	4,300-4,7000	1,000-3,000	to shape	542865168	542865284
P3	4,300-4,7000	1,000-3,000	0.5	542865169	542865285
P4	4,500-4,800	1,200-3,000	0.2	542865170	542865286
P5	4,500-4,800	1,200-2,000	0.1	542865171	542865287
P6	2,200-2,500	800	0-0.5	542863493	542868079
P7	2,200-2,500	800	0-0.5	542863494	542868080
P8	2,200-2,500	800	0-0.5	542863495	542868081

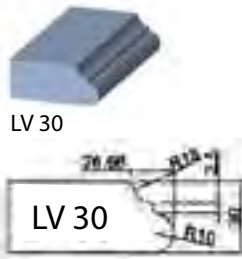

L30 COVE	LV30 COVE BULLNOSE	O30 COVE OVER DUPONT	T30 (RADIUS 3) EASED EDGE
542865140	542865208	542865148	542865164
542865141	542865209	542865149	542865165
542865142	542865210	542865150	542865166
542865143	542865211	542865151	542865167
542866657	542865422	542866663	542863490
542866658	542865423	542866664	542863491
542866659	542865424	542866665	542863492



V20 FULL BULLNOSE	V30 FULL BULLNOSE	V40 FULL BULLNOSE	V60 FULL BULLNOSE
542865176	542865180	542865184	542865188
542865177	542865181	542865185	542865189
542865178	542865182	542865186	542865190
542865179	542865183	542865187	542865191
542863502	542863505	542863508	542865428
542863503	542863506	542863509	542865429
542863504	542863507	542863510	542865430



Nicolai 60 Series CNC Tools.

Z45 Flat Edge - Outside diameter of 60 mm

Z55 Flat Edge - Outside diameter of 60 mm

ZS40 Small Bevel - Outside diameter of 65 mm

3-30 Triple Waterfall - Outside diameter of 125 mm

3-40 Triple Waterfall - Outside diameter of 140 mm

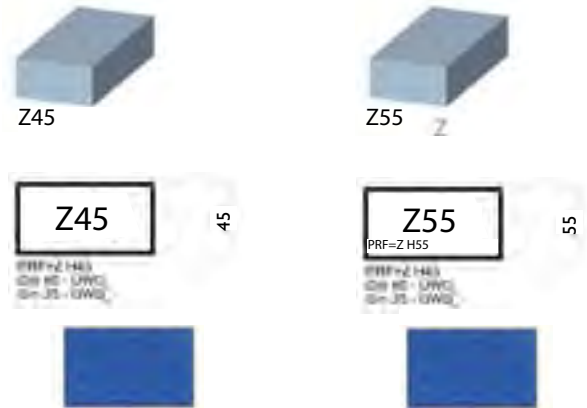

POSITION	RPM	FEED RATE MM	REMOVAL RATE MM	Z45 FLAT EDGE	Z55 FLAT EDGE
P1	4,300-4,7000	1,000-3,000	to shape	542865192	542865471
P3	4,300-4,7000	1,000-3,000	0.5	542865193	542865472
P4	4,500-4,800	1,200-3,000	0.2	542865194	542865473
P5	4,500-4,800	1,200-2,000	0.1	542865195	542865474
P6	2,200-2,500	800	0-0.5	542863517	542863520
P7	2,200-2,500	800	0-0.5	542863518	542863521
P8	2,200-2,500	800	0-0.5	542863519	542863522

4-40 Double Quarter Bevel - Outside diameter of 65 mm

5-30 Ogee Bullnose - Outside diameter of 125 mm

5-40 Ogee Bullnose - Outside diameter of 140 mm

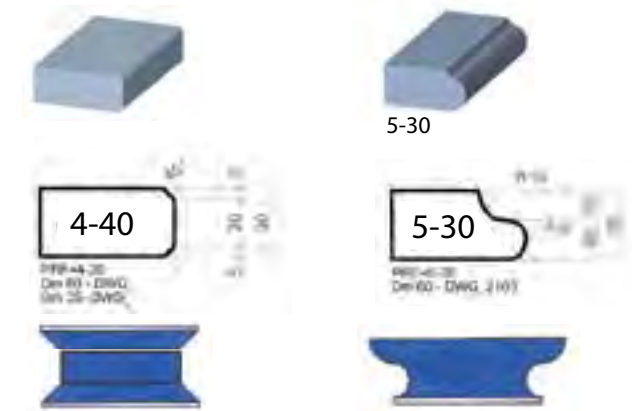

POSITION	RPM	FEED RATE MM	REMOVAL RATE MM	4-40 DOUBLE QUARTER BEVEL	5-30 OEGE BULLNOSE
P1	4,300-4,7000	1,000-3,000	to shape	542865224	542865228
P3	4,300-4,7000	1,000-3,000	0.5	542865225	542865229
P4	4,500-4,800	1,200-3,000	0.2	542865226	542865230
P5	4,500-4,800	1,200-2,000	0.1	542865227	542865231
P6	2,200-2,500	800	0-0.5	542863544	*542860996
P7	2,200-2,500	800	0-0.5	542863545	*542860998
P8	2,200-2,500	800	0-0.5	542863546	n/a

*abrasive only - 1,000 RPM, 600-800 feed rate, .015 removal rate

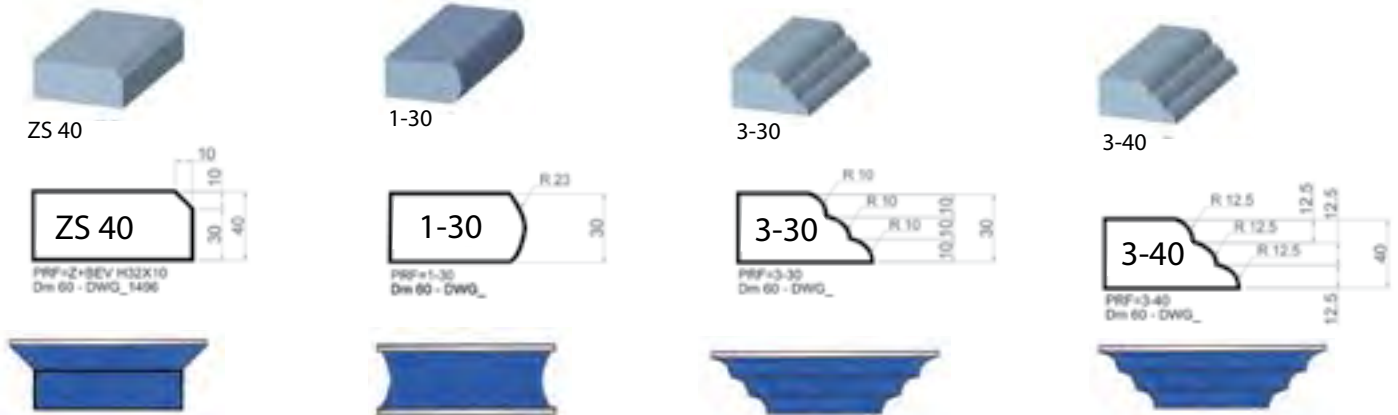

ZS40 SMALL BEVEL	1-30 CRESENT OR FRENCH BULLNOSE	3-30 TRIPLE WATERFALL	3-40 TRIPLE WATERFALL
542865200	542865216	542865220	542865479
542865201	542865217	542865221	542865480
542865202	542865218	542865222	542865481
542865203	542865219	542865223	542865482
542863535	542866696	542863538	542866702
542863536	542866697	542863539	542866703
542863537	542866698	542863540	542866704

Retrue Program

Do your CNC tools look like this?

What if they could look like this?

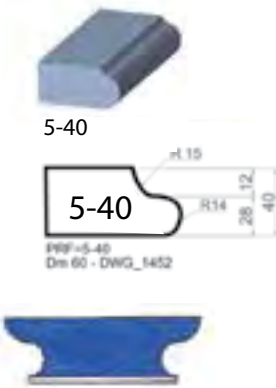

5-40 OGEE BULLNOSE
542865232
542865233
542865234
542865235
542865232
542865233
542865234

If your CNC tools are losing their shape or creating unacceptable lines, they are a potential candidate for our retooling program.

CNC tools retooled in 6 to 10 working days.

Pricing Information:

\$80.00 each for straight profile. \$85.00 each for shaped profile.

Customer pays all shipping; no taxes apply.

AVAILABLE FOR MOST CNC TOOL BRANDS ON THE MARKET TODAY!



Call to Order: 1.800.461.9589

Magnum CNC Tools.

- Made in the USA
- Available with metal P5 on request
- Available with segmented (P0) or continuous (P1) first position
- Slightly harder bond for longer life
- Call for pricing and availability. Custom shapes also available



A30r5

A30 - 5mm Radius Position 1 Continuous Rim w/slots
 A30 - 5mm Radius Position 2 Continuous Rim w/slots
 A30 - 5mm Radius Position 3 Continuous Rim w/slots
 A30 - 5mm Radius Position 4 Continuous Rim w/slots
 A30 - 5mm Radius Position 5 Consumable Resin Polisher
 A30 - 5mm Radius Position 6 Consumable Resin Polisher
 A30 - 5mm Radius Position LUX Consumable Resin Polisher

A30 - 5mm Radius Position 5 Rubber Polishing Wheel
 A30 - 5mm Radius Position 6 Rubber Polishing Wheel
 A30 - 5mm Radius Position 7 Rubber Polishing Wheel

A30 - 5mm Radius on 1/2 Gas Connection Position 1
 A30 - 5mm Radius on 1/2 Gas Connection Position 2
 A30 - 5mm Radius on 1/2 Gas Connection Position 3
 A30 - 5mm Radius on 1/2 Gas Connection Position 4



A30r10

A30 - 10mm Radius Position 1 Continuous Rim w/slots
 A30 - 10mm Radius Position 2 Continuous Rim w/slots
 A30 - 10mm Radius Position 3 Continuous Rim w/slots
 A30 - 10mm Radius Position 4 Continuous Rim w/slots
 A30 - 10mm Radius Position 5 Consumable Resin Polisher
 A30 - 10mm Radius Position 6 Consumable Resin Polisher
 A30 - 10mm Radius Position LUX Consumable Resin Polisher

A30 - 10mm Radius Position 5 Rubber Polishing Wheel
 A30 - 10mm Radius Position 6 Rubber Polishing Wheel
 A30 - 10mm Radius Position 7 Rubber Polishing Wheel



A30r15

A30 - 15mm Radius Position 0 Segmented
 A30 - 15mm Radius Position 1 Continuous Rim w/slots - Optional
 A30 - 15mm Radius Position 2 Continuous Rim w/slots
 A30 - 15mm Radius Position 3 Continuous Rim w/slots
 A30 - 15mm Radius Position 4 Continuous Rim w/slots
 A30 - 15mm Radius Position 5 Consumable Resin Polisher
 A30 - 15mm Radius Position 6 Consumable Resin Polisher
 A30 - 15mm Radius Position LUX Consumable Resin Polisher

A30 - 15mm Radius Position 5 Rubber Polishing Wheel
 A30 - 15mm Radius Position 6 Rubber Polishing Wheel
 A30 - 15mm Radius Position 7 Rubber Polishing Wheel



B30r30

B30 Position 0 Segmented
 B30 Position 1 Continuous Rim w/slots - Optional
 B30 Position 2 Continuous Rim w/slots
 B30 Position 3 Continuous Rim w/slots
 B30 Position 4 Continuous Rim w/slots
 B30 Position 5 Consumable Resin Polisher
 B30 Position 6 Consumable Resin Polisher
 B30 Position LUX Consumable Resin Polisher

B30 Position 5 Rubber Polishing Wheel
 B30 Position 6 Rubber Polishing Wheel
 B30 Position 7 Rubber Polishing Wheel



E30

E30 - 9mm Bevel Position 0 Segmented
 E30 - 9mm Bevel Position 1 Continuous Rim w/slots - Optional
 E30 - 9mm Bevel Position 2 Continuous Rim w/slots
 E30 - 9mm Bevel Position 3 Continuous Rim w/slots
 E30 - 9mm Bevel Position 4 Continuous Rim w/slots
 E30 - 9mm Bevel Position 5 Consumable Resin Polisher
 E30 - 9mm Bevel Position 6 Consumable Resin Polisher
 E30 - 9mm Bevel Position LUX Consumable Resin Polisher

E30 Position 5 Rubber Polishing Wheel
 E30 Position 6 Rubber Polishing Wheel
 E30 Position 7 Rubber Polishing Wheel



F20

F20 Position 1 Continuous Rim w/slots
 F20 Position 2 Continuous Rim w/slots
 F20 Position 3 Continuous Rim w/slots
 F20 Position 4 Continuous Rim w/slots
 F20 Position 5 Consumable Resin Polisher
 F20 Position 6 Consumable Resin Polisher
 F20 Position LUX Consumable Resin Polisher

F20 Position 5 Rubber Polishing Wheel
 F20 Position 6 Rubber Polishing Wheel
 F20 Position 7 Rubber Polishing Wheel





F30

F30 Position 1 Continuous Rim w/slots
 F30 Position 2 Continuous Rim w/slots
 F30 Position 3 Continuous Rim w/slots
 F30 Position 4 Continuous Rim w/slots
 F30 Position 5 Consumable Resin Polisher
 F30 Position 6 Consumable Resin Polisher
 F30 Position LUX Consumable Resin Polisher

F30 Position 5 Rubber Polishing Wheel
 F30 Position 6 Rubber Polishing Wheel
 F30 Position 7 Rubber Polishing Wheel



V30

V30 Position 0 Segmented
 V30 Position 1 Continuous Rim w/slots - Optional
 V30 Position 2 Continuous Rim w/slots
 V30 Position 3 Continuous Rim w/slots
 V30 Position 4 Continuous Rim w/slots
 V30 Position 5 Consumable Resin Polisher
 V30 Position 6 Consumable Resin Polisher
 V30 Position LUX Consumable Resin Polisher

V30 Position 5 Rubber Polishing Wheel
 V30 Position 6 Rubber Polishing Wheel
 V30 Position 7 Rubber Polishing Wheel



T30r3

T30 - 3mm Radius Position 1 Continuous Rim w/slots
 T30 - 3mm Radius Position 2 Continuous Rim w/slots
 T30 - 3mm Radius Position 3 Continuous Rim w/slots
 T30 - 3mm Radius Position 4 Continuous Rim w/slots
 T30 - 3mm Radius Position 5 Consumable Resin Polisher
 T30 - 3mm Radius Position 6 Consumable Resin Polisher
 T30 - 3mm Radius Position LUX Consumable Resin Polisher

T30 - 3mm Radius Position 5 Rubber Polishing Wheel
 T30 - 3mm Radius Position 6 Rubber Polishing Wheel
 T30 - 3mm Radius Position 7 Rubber Polishing Wheel



Z45

Z45 - D60 Position 1 Continuous Rim w/slots
 Z45 - D60 Position 2 Continuous Rim w/slots
 Z45 - D60 Position 3 Continuous Rim w/slots
 Z45 - D60 Position 4 Continuous Rim w/slots
 Z45 - D60 Position 5 Consumable Resin Polisher
 Z45 - D60 Position 6 Consumable Resin Polisher
 Z45 - D60 Position LUX Consumable Resin Polisher

Z45 - D60 Position 5 Rubber Polishing Wheel
 Z45 - D60 Position 6 Rubber Polishing Wheel
 Z45 - D60 Position 7 Rubber Polishing Wheel

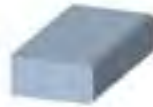

T30r5

T30 - 5mm Radius Position 0 Segmented
 T30 - 5mm Radius Position 1 Continuous Rim w/slots - Optional
 T30 - 5mm Radius Position 2 Continuous Rim w/slots
 T30 - 5mm Radius Position 3 Continuous Rim w/slots
 T30 - 5mm Radius Position 4 Continuous Rim w/slots
 T30 - 5mm Radius Position 5 Consumable Resin Polisher
 T30 - 5mm Radius Position 6 Consumable Resin Polisher
 T30 - 5mm Radius Position LUX Consumable Resin Polisher

T30 - 5mm Radius Position 5 Rubber Polishing Wheel
 T30 - 5mm Radius Position 6 Rubber Polishing Wheel
 T30 - 5mm Radius Position 7 Rubber Polishing Wheel

Z45 - D80 Position 1 Continuous Rim w/slots
 Z45 - D80 Position 2 Continuous Rim w/slots
 Z45 - D80 Position 3 Continuous Rim w/slots
 Z45 - D80 Position 4 Continuous Rim w/slots
 Z45 - D80 Position 5 Consumable Resin Polisher
 Z45 - D80 Position 6 Consumable Resin Polisher
 Z45 - D80 Position LUX Consumable Resin Polisher

Z45 - D80 Position 5 Rubber Polishing Wheel
 Z45 - D80 Position 6 Rubber Polishing Wheel
 Z45 - D80 Position 7 Rubber Polishing Wheel



Brazed Bonded Sink Wheels.

- Wheels have a 1/2 gas connection
- Perfect for smoothing sink openings and seams

SIZE INCHES (MM)	GRIT	RPM	FEED RATE INCHES (MM)	REMOVAL RATE MM	ITEM NO.	NET PRICE
1x2 (25x50)	50	5,500-6,500	28-33 (700-850)	.5-.9	542860073	\$112.00
	100				542860074	\$112.00
	200				542860075	\$112.00
2x2 (50x50)	50				542860076	\$123.00
	100				542860077	\$123.00
	200				542860078	\$123.00
SMALL DIAMETER						
5/8x2 (16x50)	50	5,500-6,500	28-33 (700-850)	.5-.9	542863393	\$153.00
1-1/4x4 (32x102)	50				542860079	\$174.00
.7x2.36 (18x60)	50				542866834	\$143.00



Seam Wheels/Cleaners



T-31 Anchor Bit System and Accessories.

- Used for bowl-hole mountings
- For a snug fit, the 3/8" shank is used for the 3/8" adapter arbor
- Individual programming necessary

DESCRIPTION	BOLT SIZE IN. (MM)	RPM	FEED RATE INCHES/MIN	ITEM NO.	NET PRICE
Adapter with 3/8" arbor	n/a*	6,000	1-2	542862403	\$41.00
13mm non-coring bit for 3/16 bolt	3/16*			542862404	\$50.00
T31 anchor bit with 3/8" shank	3/16*			542861296	\$24.00
19mm non-coring bit for 1/4" bolt	1/4*			542862405	\$61.00
T31 anchor bit with 3/8" shank	1/4*			542861297	\$29.00

* For bolt

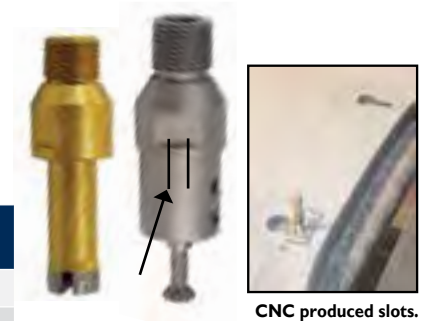

CNC produced slots.

Accessories.

DESCRIPTION	ITEM NO.	NET PRICE
A 1/2 gas collet	542860083	\$74.00
B Retainer	542861452	\$48.00
C Pliers	542861451	\$41.00



Segmented Router Bits – Step Cutter.

- Perfect for step cutting and have a segment on the bottom
- 1/2 gas connection
- Electroplated step cut routers also available

SIZE	LENGTH MM	WORKING LENGTH (LT)	RPM	FEED RATE IN/MIN (MM/MIN)	ITEM NO.	NET PRICE
28	40	95	4,800-5,500	10-20 (250-500)	542860515	\$221.00
28	40	125			542860517	\$287.00
23	25	40			542867333	\$175.00
30	30	40			542867334	\$206.00



Diamant Boart Electroplated Router Bits – Marble/Limestone.

- Use a 1/2 gas connection

SIZE/LENGTH(MM)	RPM	FEED RATE IN/MIN (MM/MIN)	ITEM NO.	NET PRICE
16/40	4,800-5,500	10-20 (250-500)	542860519	\$191.00
16/50			542860520	\$267.00
20/100			542860523	\$458.00



Call 800-845-1805
 For information on our full line of
 engraving tools, including:
PCD (polycrystalline diamond tools)



Peripheral Wheels.

- Used to cut recesses in stone for drain board included side



EDGE ANGLE	TYPE	GRIT	FITTING	ITEM NO.	NET PRICE
30° Shape	Seg	Coarse	50+3F00/063	542861062	\$587.00
	FC	Medium		542861063	\$623.00
	FC	Fine		542861065	\$623.00
	Resiline	220	F0035	542863076	\$288.00
	Resiline	400		542863077	\$288.00
	Resiline	1000		542863078	\$288.00
45° Shape	Seg	Coarse	50+3F06/063	542861068	\$551.00
	FC	Medium		542861069	\$587.00
	FC	Fine		542861070	\$587.00
	Resiline	200	F0035	542863079	\$288.00
	Resiline	400		542863080	\$288.00
	Resiline	1000		542863081	\$288.00

Flat Polishing Wheels for Drain Board.

- Used for a final polish of drain boards



DIAMETER	TYPE	GRIT	GRIT FITTING	ITEM NO.	NET PRICE
4 (100)	Res	100	Magnetic	542861080	\$191.00
		200		542861081	\$191.00
		500		542861082	\$191.00
		1,000		542861083	\$191.00
		2,000		542861084	\$191.00
		3,000		542861085	\$191.00
		Buff		542861086	\$304.00

Drainboard Mills.

- Perfect for making curved-bottom engravings or milling out of stone

DIAMETER MM	LENGTH MM	POSITION	GRIT	FITTING	ITEM NO.	NET PRICE
10	10	P1	Coarse	1/2 Gas	542861087	\$129.00
		P3	Medium		542861088	\$113.00
		P4	Fine		542861089	\$113.00
		P5	Extra Fine		542861090	\$113.00
15		P1	Coarse		542861091	\$149.00
		P3	Medium		542861092	\$139.00
		P4	Fine		542861093	\$139.00
		P5	Extra Fine		542861094	\$139.00
20		P1	Coarse		542861095	\$149.00
		P3	Medium		542861096	\$139.00
		P4	Fine		542861097	\$139.00
		P5	Extra Fine		542861098	\$139.00



6,000-6,800 RPM
400-600 mm/min
16-24 in/min

*Drainboard polish mills also available

Sinterized Mills. ■ ■ ■

- Ideal for engraving applications and making flat-bottom or flush mount grooves in stone
- Rpm's 8,000-10,000 and feed rate of 150-300 mm/min

DIAMETER mm	LENGTH mm	GRIT	FITTING	ITEM NO.	NET PRICE
8	12	Coarse	1/2 Gas	542861120	\$81.00
10				542861121	\$102.00
12				542861122	\$123.00
15				542861123	\$129.00
20				542861124	\$160.00



Electroplated Mills. Conic

DIAMETER mm	LENGTH mm	FITTING	ITEM NO.	NET PRICE
8/14 (conical)	40	1/2 Gas	542861125	\$283.00
14/20 (conical)			542861126	\$294.00
14/20 (conical)			542861127	\$324.00
14/20 (conical)	100		542861128	\$479.00



6,000-7,000 RPM
150-300 mm/min



Electroplated Mill.

- Used for engraving and do not allow for water passage
- They can be used with the collet assembly (see accessories)

DIAMETER MM	LENGTH MM	OVERALL LENGTH MM	SHANK SIZE MM	ITEM NO.	NET PRICE
Flathead / 2	10	80	6	542861111	\$27.00
3	12	60		542861112	\$27.00
4	15			542861113	\$27.00
5				542861114	\$27.00
6	12		90	10	542861115
3/5 (conical)		542861116		\$27.00	
4 (flathead)		542861117		\$74.00	
5 (flathead)		542861118		\$74.00	
6 (flathead)				542861119	\$74.00



8,000-10,000 RPM
150-300 mm/min

Widia Mills.

- All can be used on marble except the two noted below*
- Other mill sizes available

TIP DIA. INCHES (MM)	TIP LENGTH IN (MM)	TIP ANGLE	FITTING	ITEM NO.	NET PRICE
1/8 (3)	1-1/4 (30)	15°	1/2 Gas	542861133	\$133.00
3/16 (5)/15	1-1/4 (30)	15°	1/2 Gas	542861134	\$133.00
3/16 (5)/22	2 (50)	15°	1/2 Gas	542861135	\$232.00
3/32 (8)/15	1-1/4 (30)	15°	1/2 Gas	542861136	\$133.00
3/32 (8)/22	2 (50)	15°	1/2 Gas	542861137	\$232.00
3/8 (10)	3/8 (10)	90°	CIL 010	542861140*	\$23.00
3/8 (10)	3/8 (10)	90°	CIL 010	542861141*	\$23.00
5/8 (15)	3/8 (10)	90°	CIL 010	542861142*	\$30.00
5/8 (15)	3/8 (10)	90°	CIL 010	542861143*	\$30.00



8,000-10,000 RPM
150-250 mm/min

* can be used with collet assembly

Accessories.

DESCRIPTION	ITEM NO.	NET PRICE
Pliers - D2/3	542865057	\$41.00
Pliers - D4	542865059	\$41.00
Pliers - D5/6	542865058	\$41.00
Pliers - D7/8	542865060	\$41.00
Pliers - D9/10	542861451	\$41.00
Pliers - D11/12	542865061	\$41.00
Wrench for the retainer	542867378	\$31.00
1/2 gas collet	542860083	\$74.00
Retainer	542861452	\$48.00



Electroplated Ball Head Mills. ■ Limestone

DIAMETER INCHES (MM)	LENGTH INCHES (MM)	GRIT	LENGTH	ITEM NO.	NET PRICE
1-1/4 (30)	3/4 (20)	Coarse	L-15	542861144	\$298.00
		Medium	L-20	542861145	\$267.00
1-1/2 (40)	1 (25)	Coarse	L-25	542861146	\$359.00
		Medium	L-25	542861147	\$308.00
2 (50)	1-1/4 (30)	Coarse	L-30	542861148	\$438.00
		Medium	L-30	542861149	\$366.00
2-3/8 (60)	1-3/8 (35)	Coarse	L-35	542861150	\$546.00
		Medium	L-35	542861151	\$443.00
2-3/4 (70)	1-1/2 (40)	Coarse	L-40	542863306	\$577.00
		Medium	L-40	542863307	\$577.00



5,000-5,500 RPM
200-400 mm/min

Segmented Ball Head Mills. ■ ■ ■

DIAMETER INCHES (MM)	LENGTH INCHES (MM)	GRIT	LENGTH	ITEM NO.	NET PRICE
1-1/4 (30)	3/4 (20)	Coarse	L-15	542861152	\$184.00
		Medium	L-20	542861153	\$170.00
1-1/2 (40)	1 (25)	Coarse	L-25	542861154	\$267.00
		Medium	L-25	542861155	\$242.00
2 (50)	1-1/4 (30)	Coarse	L-30	542861156	\$366.00
		Medium	L-30	542861157	\$330.00
2-3/8 (60)	1-3/8 (35)	Coarse	L-35	542861158	\$483.00
		Medium	L-35	542861159	\$438.00
2-3/4 (70)	1-1/2 (40)	Coarse	L-40	542863304	\$510.00
		Medium	L-40	542863305	\$510.00



4,500-5,000 RPM
200-400 mm/min

CNC Blades.

- Used for cutting granite/marble (Concave only) or granite only depending on the blade
- Other blade diameters and applications available, custom arbors and hole patterns are also available

DIAMETER INCHES (MM)	TYPE	SEGMENT NUMBER	CORE	FITTING	MACHINE	ITEM NO.	NET PRICE
7 (180)	Concave	Z18+6RFC	Standard	50+4D6/63	CMS Brembana	542861160	\$350.00
6 1/4 (160)	Concave	Z16			CMS Brembana-Techno	542861164	\$318.00
8 (210)	Flat	Z24 20x3.6x6	Silent	50	CMS Brembana	542861167	\$215.00
8 (210)	Flat	13			"Speedcut" for all CNCs	542862320	\$201.00



CNC Accessories

- CNC Toolholder Cones and Adapters are available for more CNC machines
- Machine tool holders for Prussiani, Bavelloni and other machines are also available, please call for details

MACHINE NAME	DESCRIPTION	ITEM NO.	NET PRICE	
PRE-2002 CMS BREMBANA	ISO40 35/39 male	542860291	\$232.00	
	ISO40 1/2 gas female	542860292	\$232.00	
POST-2002 CMS BREMBANA	ISO40 35/39 male	542867404	\$206.00	
	ISO40 1/2 gas female	542867407	\$180.00	
	Adapter for D50+6H for 1/2 gas cone for calibrating/stubbing wheels	542861196	\$130.00	
	ISO40 35/80 male	542867406	\$232.00	
	ISO40 D65+6H cone for calibrating/stubbing wheels	542861334	\$232.00	
	ISO40 35/47	ISO40 D/board cone for drain board brembana	542861358	\$258.00
		1/2 gas - M30 terzago for drain board polish CMS Brembana	542862110	\$77.00
		M30 terzago connection for drain board polish CMS Brembana	542862111	\$77.00
		Terzago key (Nicolai) for drain board polish CMS Brembana	542862112	\$40.00
Intermac	ISO40 35/39 male	542867408	\$206.00	
	ISO40 35/47 male	542867409	\$206.00	
	ISO40 35/59 male	542863008	\$206.00	
	ISO40 35/80 male	542867410	\$232.00	
	ISO40 1/2 gas female	542867411	\$180.00	
Park Destiny & Odyssey	BT40 35/39 male	542867412	\$206.00	
	BT40 35/47 male	542867413	\$206.00	
	BT40 1/2 gas female	542867415	\$180.00	
Park New Line	BT40 35/39 male	542867416	\$206.00	
	BT40 35/47 male	542867417	\$206.00	
	BT40 1/2 gas female	542867419	\$180.00	
Northwood Generation 1	B40 35/37 male (includes pull-stud)	542867424	\$206.00	
	B40 35/47 male (includes pull-stud)	542867425	\$206.00	
	B40 1/2 gas female (includes pull-stud)	542867427	\$180.00	
	Northwood pull stud generation 1	542867428	\$36.00	
Northwood Generation 2	B40 35/37 male (includes pull-stud)	542867438	\$206.00	
	B40 35/47 male (includes pull-stud)	542867429	\$206.00	
	B40 1/2 gas female (includes pull-stud)	542867431	\$180.00	
	Northwood pull stud generation 2	542867441	\$36.00	
Northwood Generation 3	B40 35/37 male (includes pull-stud)	542867432	\$206.00	
	B40 35/47 male (includes pull-stud)	542867433	\$206.00	
	B40 1/2 gas female (includes pull-stud)	542867435	\$180.00	
	Northwood pull stud generation 3	542867436	\$36.00	





Service

Diamant Boart is your partner in the stone industry. Our fully staffed service centre offers a wide range of services including:

- Production of new 12" to 13' blades using state of the art manufacturing equipment, cores and segments.
- Segment re-tipping of 12" to 13' blades.
- Quality control program to ensure consistent, high quality products at all facilities.
- Blade inspection (segment analysis and core integrity).
- Repair of damaged blades.
- Technical service/product recommendations and expertise.
- Continual reinforcement of the importance of safety issues as they pertain to the use of all our products.
- Complete stocked inventory of cores and segments.

Customer Service

Our teams are dedicated to customer service and deliver quick response to all your needs including:

- Order processing/administration.
- Shipment logistics.
- Coordinated order follow-up.
- Inventory management to accommodate regional customer needs.

Scan the QR-tag to view the
Diamant-Boart Service Video



Diamant Boart On-Site Service

We are proud to support our customers in the field as well as at our service centers.

Several on-site services include:

- Inspection and evaluation of large diameter cores for tension and run-out.
- Evaluating segment wear to ensure maximum productivity.
- Segment dressing/sharpening.
- Re-tipping.
- Confirming operational integrity of the saws and equipment being used.
- Quarry and stationary wire sawing training and performance improvement programs.

Our on-site support staff is trained to work with you and tailor segments for processing materials to fit your needs.

We spend quality time to understand your needs and help to improve your production.

Processing Blades/Segments



Diamant Boart segments and laser welded blades are engineered and produced using state of the art equipment and processes at our factory in Columbia, SC. Our brazed blades and re-tipped blades are produced at our service centers using automated brazing and de-brazing equipment and precise, high output grinding machines.

Block Sawing Blades/Segments:

- Segments in various sizes to cover all stone applications for limestone, granite, sandstone, bluestone and marble.
- Specifications are also designed to perform consistently based on stone type, size and saw being used.

Segment Configurations:

- Multi-layer building block segments in 5 or 7 layers.
- Sandwich style.
- Diamant Boart's R&D department is constantly developing new segments based on customer needs and production parameters.

Cores

- Diamant Boart supplies cores of all sizes and for all saws based on the demands of the application with special care given to ongoing core maintenance/inspection.

Many different segment designs (length, height, shape) are available as well as core configurations for maximizing productivity and accuracy of cut. Our commitment to developing new and innovative segment designs has put us in the forefront of the thin veneer sawing industry.

Thin Veneer Sawing Blades/Segments

- Designed for high output plunge sawing of all stones for the production of flat or 90 degree corner thin veneer stone cladding.
- Size range is from 20" and 24" (masonry saws) to up to 48" for high output on higher HP single and multi-head saws.
- Segment/blade specifications are designed around the HP of the saw being used as well as RPM (surface feet/minute), arbor design, production parameters and the stone being cut.

Core options are based on:

- Number of landings based on application.
- Various thickness based on the application.
- Silent cores - copper riveted, laser-cut.
- Diamant Boart works with our core manufacturers to develop new core designs as industry demands evolve.



Diamond Wire

All wire is manufactured at our facilities in Belgium and Portugal. The development of Vinci bead technology took place at our factory in Ath, Belgium and is an innovative process exclusive to Diamant Boart. We have a complete line of wire for quarry, stationary and profiling applications. Inventory is maintained at our service centers.





Quarry

- High production, long life vulcanized rubber injected 11 mm or 12 mm diameter bead wire in 36 or 40 beads/meter.



Single and Multi-Wire

- Single/stationary wire is available in 8.3 mm and 10 mm diameter in 36 and 40 beads/meter.
- Available for all makes of machine for slab production or sawing profiles.
- Multi-Wire is available in 7.3 mm diameter and is used extensively in high production applications using multiple strands of wire for processing slabs.
- Our team of service center technicians and our wire Product Manager are available for on-site demonstrations, technical support and training on the use of all Diamant Boart wires.

Wire sawing parameters include:

- Machine manufacturer.
- Type of machine.
- HP of machine.
- Guide wheels diameter and number.
- Maximum height and average surface of cut.
- Wire length.
- Wire crimping and twisting.
- Cutting speed based on the application.
- Stone hardness.

Diamant Board - North Bay
2077 Bond Street
North Bay, ON P1B 4V7
Toll Free phone: +1-800-461-9589
Customer Service Fax:+1-800-825-0028
Customer Service Email: hcpcustomer.service@husqvarna.com
<http://www.diamantboard.com>

Diamant Boart
Corporate Office
17400 West 119th Street
Olathe, KS 66061
Phone: 913-928-1000
Fax: 913-438-7971

Diamant Boart - Columbia
10250 Two Notch Rd.
Columbia, SC 29229
Phone Toll Free: 800-845-1312
Fax: 800-257-9284

Diamant Boart - Dallas
2933 Eisenhower Rd. Ste 160
Carrollton, TX 75007
Phone: 888-928-8955
Fax: 214-351-9998

Diamant Boart - Elberton
346 East Tate Street
P. O. Box 639
Elberton, GA 30635
Phone: 706-213-0058
Phone Toll Free: 888-213-5508
Fax: 706-213-1332

Diamant Boart - Kingsley
RR 1, Box 195
Kingsley, PA 18826
Phone: 570-222-4131
Phone Toll Free: 800-875-4131
Fax: 570-222-4165

Scan the QR-tag to
visit our website.



www.diamant-boart.com

www.husqvarnacp.com