

Robert Larson

2013 Woodworking Tool Catalog



Hand Tools
Since 1981



TWO CHERRIES CHISELS



Since 1858

Two Cherries tools are still largely made in the same way in which they were made decades ago. Where change has been introduced it has only enhanced the quality of the product. The finest steel is used throughout the product line, and skilled craftsmen still work with diligence to bring you a tool that you will be proud to own and love to work with. In fact, your children and grandchildren will be just as pleased to use these tools that are tools made with care.

Chisel Sets Wooden Handles

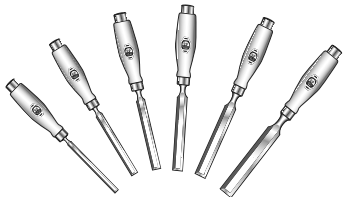

Two different sets of high quality Two Cherries bevel edge chisels with hardwood handles. The set of six chisels consists of sizes 6-10-12-16-20-26mm, the set of four consists of 10-16-20-26mm.

500-1562 Set of Six
500-1564 Set of Four

Chisel Sets Plastic Handles

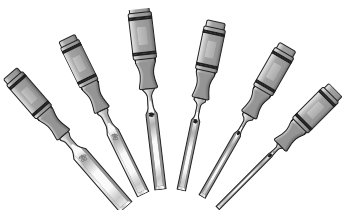

Two different sets of high quality Two Cherries bevel edge chisels with cellulose acetate plastic handles. The set of six chisels consists of sizes 6-10-12-16-20-26mm and the set of four consists of 10-16-20-26mm.

500-3562 Set of Six
500-3564 Set of Four

Bevel Edge Chisels

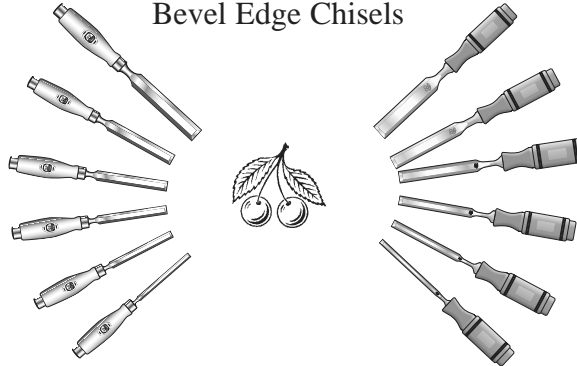

These chisels are made of the highest quality German steel. Carefully made, polished all-around. One of the finest tools made in the world! Ten to fourteen inches in overall length. Choose between a traditional and well proportioned wooden handle, or nearly unbreakable cellulose acetate plastic handle. A number of sets are available which include the most important sizes. Inch sizing is approximate.

Carefully forged blades are skillfully heat treated in an immersion bath method to achieve a Rockwell hardness of 61°C. This means that sharpening the chisels may take a few extra minutes, but they will hold an edge significantly longer than almost any other chisels! After heat treating, the blades are polished to a rich finish that makes them a joy to use. Fitting appropriate handles is the final step in producing these highest quality German chisels.



Wooden Handled Chisels

500-1502 2 mm	500-1520 3/4" 20 mm
500-1503 1/8" 3 mm	500-1522 22 mm
500-1504 3/16" 4 mm	500-1524 24 mm
500-1506 1/4" 6 mm	500-1526 1" 26 mm
500-1508 8 mm	500-1528 28 mm
500-1510 3/8" 10 mm	500-1530 1 1/4" 30 mm
500-1512 1/2" 12 mm	500-1532 32 mm
500-1514 14 mm	500-1535 35 mm
500-1516 3/8" 16 mm	500-1540 1 1/2" 40 mm
500-1518 18 mm	500-1545 45 mm
	500-1550 2" 50 mm



Plastic Handled Chisels

500-3502 1/8" 2mm	500-3512 1/2" 12mm
500-3504 3/16" 4mm	500-3516 3/8" 16mm
500-3506 1/4" 6mm	500-3520 3/4" 20mm
500-3510 3/8" 10mm	500-3526 1" 26mm
	500-3530 1 1/4" 30mm

Boxed Chisel Sets

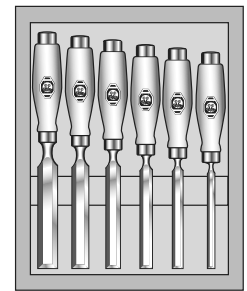

Set of four and a set of six wooden handled bevel edge chisels in a fitted wooden box. Keeps your chisels protected in storage and ready to use. Set of six contains 6-10-12-16-20-26mm chisels. Set of four contains 10-16-20-26mm chisels.
500-1559 Set of Four in Wooden Box
500-1561 Set of Six in Wooden Box

Set of Chisels in Leather Tool Roll

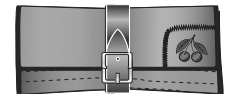
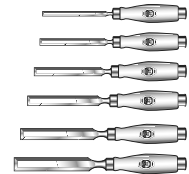

High quality Two Cherries leather tool roll with six bevel edge chisels with wooden handles described on this page. Sizes 6-10-12-16-20-26mm. There are an additional six pockets within the tool roll for future tools. This is an ideal set for any woodworker.

500-1575 Two Cherries Chisels in Roll

Two Cut Multi Tool



Universal tool from *Two Cherries* with two cutting edges - front and side. At last one tool for mortising, cutting, scraping, peeling, notching, slitting, marking . . . for every craftsman and do-it-yourselfer.

Double-edged for multiple use with the cutting edges ground on both sides and mirror bright polished. Usable length is hardened in a salt bath to 60 1/2 HRC. The handle can be used with plastic or wooden mallet. Great for carpenters, roofers, boat builders, cabinet makers, carvers, drywallers, hardwood floor installers, maintenance engineers, and do-it-yourselfers. Front cutting edge is a 26 mm width for chiseling and mortising. Side cutting edge is an extra long 90 mm for all cutting purposes. Blade and handle are made in Germany

500-5026 Two Cut Chisel 26mm





TWO CHERRIES CHISELS

Mortise Chisels

A heavy tool in a strong pattern. A truly impressive tool for mortising. This tool has a heavy, round hornbeam handle and a leather disc shock absorber. Overall length about 13" to 14". This is the correct tool for cutting deep and straight mortises in all types of wood.

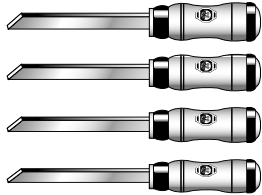

500-2199 Set of Four

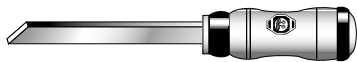

500-2006 6 mm
 500-2008 8 mm
 500-2010 10 mm
 500-2012 12 mm

Swan Neck
Mortise Chisel

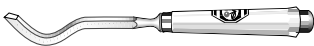

Use in conjunction with the mortise chisels above for cleaning the bottom of a mortise. Similar in construction to the mortise chisel with an overall length is about 12" to 15".

500-2106 6 mm
 500-2110 10 mm
 500-2112 12 mm

Bevel Edge Chisel
Curved Blade



This is a real problem solver tool! While you might not pick it up to use each day, you will find yourself using it more and more, doing work that you could not have easily done before. Skilled craftsmen throughout the world have been amazed at the variety of uses for these tools, and "problems" that this unique tool has solved for them. These three chisels are the same high quality as all Two Cherrys chisels, and are fitted with a wooden handle.

500-1710 10mm
 500-1716 16mm
 500-1720 20mm

Set of Four Butt Chisels — Wooden Handles



Ideal for precise bench work these handsome, shorter chisels fit comfortably in the palm of your hand. Chisels are approximately 6 5/8" overall length and the set consists of 6mm, 12mm, 20mm and 26mm (1/4", 1/2", 3/4", 1") sizes. Made of Two Cherrys' high quality steel and hardened to a Rockwell hardness of HRC 61.

500-4575 Set of Four Wood Handled Butt Chisels

Bevel Edge Chisel Sets In
Wooden Case

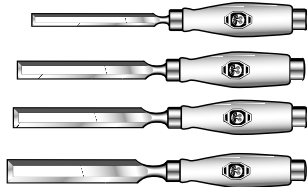

Unpolished sets of Two Cherrys chisels. These tools are nearly identical to the standard production tools shown on the previous page. The only differences are that the blades are not high polished and a slightly different shaped wooden handle is used. Same steel, same forging, same heat treating, same grinding. An economical alternative for the woodworker on a budget. Available in a set of four containing 10, 16, 20, and 26mm chisels, or a set of six which adds a 6mm and 12mm chisel.

500-9050 Four Chisels in Wood Box
 500-9060 Six Chisels in Wood Box

Skew Chisels

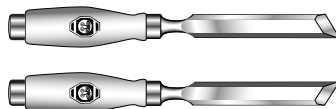

Two Cherrys bevel edge chisels with a skew cutting edge. This design permits hand controlled paring and other types of detail work. It is very practical for trimming slightly protruding dovetails, tenons, dowels and other applications when finesse, not chopping is required. Available in three sizes and sold as left and right angled pairs. Wooden handles.

500-1912 12mm Skew Chisels (Pair)
 500-1920 20mm Skew Chisels (Pair)
 500-1926 26mm Skew Chisels (Pair)

Gouges

Two styles of fine quality hand forged Gouges. Out-Cannel has cutting edge on the front side. In-Cannel has cutting edge on the back side. Overall lengths of approximately ten to eleven inches.



Out-Cannel Size
 500-1006 6 mm
 500-1012 12 mm
 500-1020 20 mm
 500-1025 26 mm



In-Cannel Size
 500-1106 6 mm
 500-1112 12 mm
 500-1120 20 mm
 500-1126 26 mm

Curved Gouge



An extremely useful variation on the firmer gouge. Bevel is on the outside of the blade, and the tool has an overall length of nine to eleven inches. Highest quality German steel.

500-0906 6 mm
 500-0912 12 mm
 500-0920 20 mm
 500-0925 26 mm

Replacement Handles



Replacement wooden handles available in five sizes. Fit is specified for the bevel edge chisels.

Number	Fits Blades	Length
500-1620	2 mm-10 mm	120 mm
500-1625	12 mm-16 mm	125 mm
500-1630	20 mm-26 mm	130 mm
500-1640	30 mm	140 mm
500-1650	40 mm-50 mm	150 mm

Problem Solver Kit

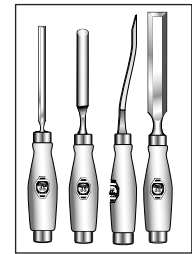

Kit of four tools especially selected to deal with troublesome woodworking issues. Includes: 4 and 26 mm bevel edge chisels, 12mm firmer gouge and 20mm curved chisel. With the Problem Solver Kit you always have the right chisel on hand. Comes in a fitted wooden box.

500-1850 Problem Solver Kit

90 Degree Mortise Chisel

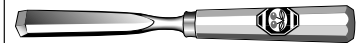

A handy, timesaving tool used after drilling or routing a mortise. The tool is an inside bevel 90° chisel used to square the mortise corners.

500-4050 12mm Mortise Chisel

Two Cherrys
Chisel Edge Guards

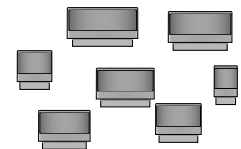

The same chisel edge guards that come with the Two Cherrys bevel edge chisels. Sizes for chisels 6, 10, 12, 16, 20, and 26mm.

500-1590 Set of Six



Carpenter Pencil



Some craftsmen might say that there is no difference in one carpenter's pencil to another -- until the day they start to use this fantastic German marking tool.

524-7000 Carpenter Pencil



TWO CHERRIES CARVING TOOLS

Traditional Full Size Tools

In production for over one hundred and fifty years, are available in nearly 750 different sizes and shapes. There are no carving chisels made anywhere in the world today that surpass the quality of these German tools. These are professional, long model tools, fine polished inside and outside, with a blade length (without tang) of 125mm.

Sharpened Edges

Two Cherries carving tools now come sharpened for use, directly from the factory. Simply take the tool out of the package and get to work!

Numbering

Ordering carving tools can be confusing, so here is an explanation of the numbering system for our full size professional tools. All our tools have a seven digit number (XXX-XXXX). The first three digits for all professional carving tools is 505 (505-XXXX). The next two digits indicate the "sweep" of the tool (505-08XX). The last two digits indicate the width of the cutting edge (505-0812). The preceding example (505-0812) indicates a professional Two Cherries #8-sweep straight gouge with a cutting edge of 12mm. Note that the sweep illustrations are not shown to size.

Handles

All tools come standard with a fine quality octagon handle. In addition, all tools of 25mm or larger have double-hooped handles for added strength.



Sweep #1

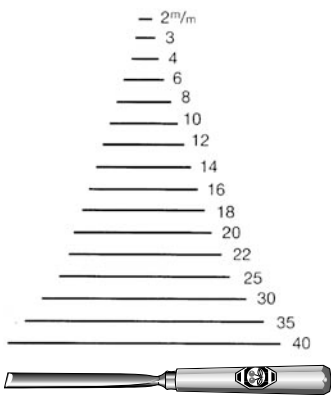

505-0102	Straight Chisel	02mm
505-0103	Straight Chisel	03mm
505-0104	Straight Chisel	04mm
505-0106	Straight Chisel	06mm
505-0108	Straight Chisel	08mm
505-0110	Straight Chisel	10mm
505-0112	Straight Chisel	12mm
505-0114	Straight Chisel	14mm
505-0116	Straight Chisel	16mm
505-0118	Straight Chisel	18mm
505-0120	Straight Chisel	20mm
505-0125	Straight Chisel	25mm
505-0130	Straight Chisel	30mm
505-0135	Straight Chisel	35mm



505-0202	Skew Chisel	02mm
505-0203	Skew Chisel	03mm
505-0204	Skew Chisel	04mm
505-0206	Skew Chisel	06mm
505-0208	Skew Chisel	08mm
505-0210	Skew Chisel	10mm
505-0212	Skew Chisel	12mm
505-0214	Skew Chisel	14mm
505-0216	Skew Chisel	16mm
505-0218	Skew Chisel	18mm
505-0220	Skew Chisel	20mm
505-0225	Skew Chisel	25mm
505-0230	Skew Chisel	30mm
505-0235	Skew Chisel	35mm

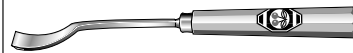

505-2103	Spoon Bent	03mm
505-2106	Spoon Bent	06mm
505-2112	Spoon Bent	12mm
505-2116	Spoon Bent	16mm
505-2118	Spoon Bent	18mm



505-7102	Spade Chisel	02mm
505-7106	Spade Chisel	06mm
505-7110	Spade Chisel	10mm
505-7112	Spade Chisel	12mm
505-7116	Spade Chisel	16mm

Sweep #3

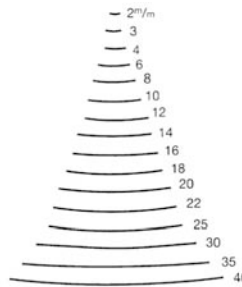

505-0302	Straight Gouge	02mm
505-0303	Straight Gouge	03mm
505-0304	Straight Gouge	04mm
505-0306	Straight Gouge	06mm
505-0308	Straight Gouge	08mm
505-0310	Straight Gouge	10mm
505-0312	Straight Gouge	12mm
505-0314	Straight Gouge	14mm
505-0316	Straight Gouge	16mm
505-0318	Straight Gouge	18mm
505-0320	Straight Gouge	20mm
505-0325	Straight Gouge	25mm
505-0330	Straight Gouge	30mm
505-0335	Straight Gouge	35mm



505-2404	Spoon Bent	04mm
505-2406	Spoon Bent	06mm
505-2412	Spoon Bent	12mm
505-2416	Spoon Bent	16mm
505-2418	Spoon Bent	18mm
505-2425	Spoon Bent	25mm



505-3310	Back Bent	10mm
----------	-------	-----------	-------	------



505-7304	Spade Gouge	04mm
505-7308	Spade Gouge	08mm
505-7316	Spade Gouge	16mm

Sweep #4

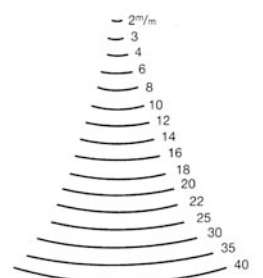

505-0402	Straight Gouge	02mm
505-0403	Straight Gouge	03mm
505-0404	Straight Gouge	04mm
505-0406	Straight Gouge	06mm
505-0408	Straight Gouge	08mm
505-0410	Straight Gouge	10mm
505-0412	Straight Gouge	12mm
505-0414	Straight Gouge	14mm
505-0416	Straight Gouge	16mm
505-0418	Straight Gouge	18mm
505-0420	Straight Gouge	20mm
505-0425	Straight Gouge	25mm
505-0430	Straight Gouge	30mm
505-0435	Straight Gouge	35mm

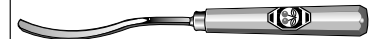

505-1306	Long Bent	06mm
505-1310	Long Bent	10mm
505-1312	Long Bent	12mm
505-1314	Long Bent	14mm
505-1316	Long Bent	16mm
505-1320	Long Bent	20mm
505-1322	Long Bent	22mm
505-1325	Long Bent	25mm



505-2504	Spoon Bent	04mm
505-2506	Spoon Bent	06mm
505-2512	Spoon Bent	12mm
505-2516	Spoon Bent	16mm
505-2518	Spoon Bent	18mm
505-2525	Spoon Bent	25mm

Two Cherries Sharpening DVD



An instructional DVD from Two Cherries covering the sharpening of chisel and plane blades, as well as a wide range of carving tool sweeps and sizes, from 1mm micro gouges to 3" fishtail tools, V-tools, and more. The sharpening methods demonstrated use only easy to find sharpening equipment and shop-made jigs. The techniques do not require the use of hard to find or expensive equipment. The instructor also shows how to repair and restore a damaged cutting edge. DVD can be played in English, Spanish, German, Dutch, or French. Approximately 73 minutes.
524-7500.....Sharpening Video



CARVING TOOLS



Sweep #5



- 505-0502 Straight Gouge..... 02mm
- 505-0503 Straight Gouge..... 03mm
- 505-0504 Straight Gouge..... 04mm
- 505-0506 Straight Gouge..... 06mm
- 505-0508 Straight Gouge..... 08mm
- 505-0510 Straight Gouge..... 10mm
- 505-0512 Straight Gouge..... 12mm
- 505-0514 Straight Gouge..... 14mm
- 505-0516 Straight Gouge..... 16mm
- 505-0518 Straight Gouge..... 18mm
- 505-0520 Straight Gouge..... 20mm
- 505-0522 Straight Gouge..... 22mm
- 505-0525 Straight Gouge..... 25mm
- 505-0530 Straight Gouge..... 30mm
- 505-0535 Straight Gouge..... 35mm



- 505-1406 Curved Gouge 06mm
- 505-1410 Curved Gouge 10mm
- 505-1412 Curved Gouge 12mm
- 505-1414 Curved Gouge 14mm
- 505-1416 Curved Gouge 16mm
- 505-1420 Curved Gouge 20mm
- 505-1422 Curved Gouge 22mm
- 505-1425 Curved Gouge 25mm



- 505-2604 .. Spoon Bent Gouge..... 04mm
- 505-2606 .. Spoon Bent Gouge..... 06mm
- 505-2610 .. Spoon Bent Gouge..... 10mm
- 505-2612 .. Spoon Bent Gouge..... 12mm
- 505-2616 .. Spoon Bent Gouge..... 16mm
- 505-2618 .. Spoon Bent Gouge..... 18mm



- 505-7516 Spade Gouge 16mm

Sweep #6

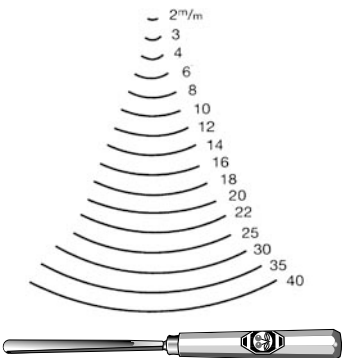

- 505-0602 Straight Gouge..... 02mm
- 505-0603 Straight Gouge..... 03mm
- 505-0604 Straight Gouge..... 04mm
- 505-0606 Straight Gouge..... 06mm
- 505-0608 Straight Gouge..... 08mm

- 505-0610 Straight Gouge..... 10mm
- 505-0612 Straight Gouge..... 12mm
- 505-0614 Straight Gouge..... 14mm
- 505-0616 Straight Gouge..... 16mm
- 505-0618 Straight Gouge..... 18mm
- 505-0620 Straight Gouge..... 20mm
- 505-0625 Straight Gouge..... 25mm
- 505-0630 Straight Gouge..... 30mm
- 505-0635 Straight Gouge..... 35mm



- 505-1506 Curved Gouge 06mm
- 505-1510 Curved Gouge 10mm
- 505-1512 Curved Gouge 12mm
- 505-1514 Curved Gouge 14mm
- 505-1516 Curved Gouge 16mm
- 505-1520 Curved Gouge 20mm
- 505-1525 Curved Gouge 25mm
- 505-1535 Curved Gouge 35mm

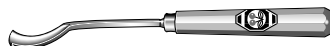

- 505-2704 .. Spoon Bent Gouge..... 04mm
- 505-2706 .. Spoon Bent Gouge..... 06mm
- 505-2712 .. Spoon Bent Gouge..... 12mm
- 505-2716 .. Spoon Bent Gouge..... 16mm
- 505-2718 .. Spoon Bent Gouge..... 18mm



- 505-3606 .. Back Bent Gouge..... 06mm
- 505-3610 .. Back Bent Gouge..... 10mm



- 505-7602 Spade Gouge 02mm
- 505-7606 Spade Gouge 06mm
- 505-7610 Spade Gouge 10mm
- 505-7616 Spade Gouge 16mm

Sweep #7

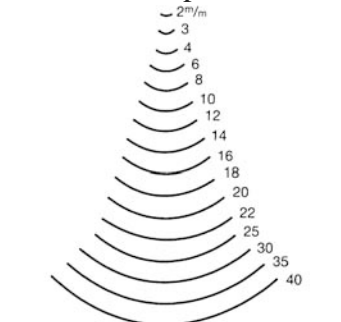

- 505-0702 Straight Chisel..... 02mm
- 505-0703 Straight Chisel..... 03mm
- 505-0704 Straight Chisel..... 04mm
- 505-0706 Straight Chisel..... 06mm
- 505-0708 Straight Chisel..... 08mm
- 505-0710 Straight Chisel..... 10mm
- 505-0712 Straight Chisel..... 12mm
- 505-0714 Straight Chisel..... 14mm
- 505-0716 Straight Chisel..... 16mm
- 505-0718 Straight Chisel..... 18mm
- 505-0720 Straight Chisel..... 20mm
- 505-0725 Straight Chisel..... 25mm
- 505-0730 Straight Chisel..... 30mm
- 505-0735 Straight Chisel..... 35mm



- 505-1606 Curved Gouge 06mm
- 505-1610 Curved Gouge 10mm



- 505-1612 Curved Gouge 12mm
- 505-1614 Curved Gouge 14mm
- 505-1616 Curved Gouge 16mm
- 505-1620 Curved Gouge 20mm
- 505-1625 Curved Gouge 25mm



- 505-2804 .. Spoon Bent Gouge..... 04mm
- 505-2806 .. Spoon Bent Gouge..... 06mm
- 505-2808 .. Spoon Bent Gouge..... 08mm
- 505-2810 .. Spoon Bent Gouge..... 10mm
- 505-2812 .. Spoon Bent Gouge..... 12mm
- 505-2816 .. Spoon Bent Gouge..... 16mm
- 505-2818 .. Spoon Bent Gouge..... 18mm



- 505-7702 Spade Gouge 02mm
- 505-7706 Spade Gouge 06mm
- 505-7710 Spade Gouge 10mm
- 505-7716 Spade Gouge 16mm

Sweep #8

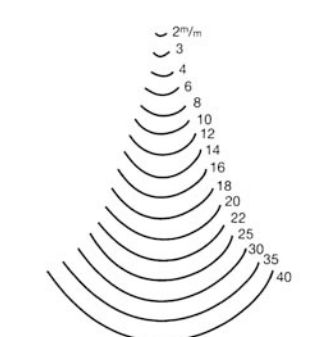

- 505-0802 Straight Gouge..... 02mm
- 505-0803 Straight Gouge..... 03mm
- 505-0804 Straight Gouge..... 04mm
- 505-0806 Straight Gouge..... 06mm
- 505-0808 Straight Gouge..... 08mm
- 505-0810 Straight Gouge..... 10mm
- 505-0812 Straight Gouge..... 12mm
- 505-0814 Straight Gouge..... 14mm
- 505-0816 Straight Gouge..... 16mm
- 505-0818 Straight Gouge..... 18mm
- 505-0820 Straight Gouge..... 20mm
- 505-0825 Straight Gouge..... 25mm
- 505-0830 Straight Gouge..... 30mm
- 505-0835 Straight Gouge..... 35mm



- 505-1706 Curved Gouge 06mm
- 505-1710 Curved Gouge 10mm
- 505-1712 Curved Gouge 12mm
- 505-1714 Curved Gouge 14mm
- 505-1716 Curved Gouge 16mm
- 505-1720 Curved Gouge 20mm
- 505-1725 Curved Gouge 25mm



- 505-2904 .. Spoon Bent Gouge..... 04mm
- 505-2906 .. Spoon Bent Gouge..... 06mm
- 505-2908 .. Spoon Bent Gouge..... 08mm
- 505-2910 .. Spoon Bent Gouge..... 10mm
- 505-2912 .. Spoon Bent Gouge..... 12mm
- 505-2918 .. Spoon Bent Gouge..... 18mm



Sweep #9

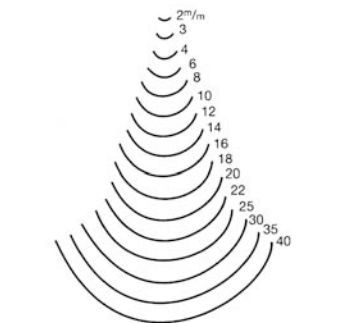

- 505-0902 Straight Gouge..... 02mm
- 505-0903 Straight Gouge..... 03mm
- 505-0904 Straight Gouge..... 04mm
- 505-0906 Straight Gouge..... 06mm
- 505-0908 Straight Gouge..... 08mm
- 505-0910 Straight Gouge..... 10mm
- 505-0912 Straight Gouge..... 12mm
- 505-0914 Straight Gouge..... 14mm
- 505-0916 Straight Gouge..... 16mm
- 505-0918 Straight Gouge..... 18mm
- 505-0920 Straight Gouge..... 20mm
- 505-0925 Straight Gouge..... 25mm
- 505-0930 Straight Gouge..... 30mm
- 505-0935 Straight Gouge..... 35mm



- 505-1806 Curved Gouge 06mm
- 505-1808 Curved Gouge 08mm
- 505-1810 Curved Gouge 10mm
- 505-1812 Curved Gouge 12mm
- 505-1814 Curved Gouge 14mm
- 505-1816 Curved Gouge 16mm
- 505-1820 Curved Gouge 20mm
- 505-1825 Curved Gouge 25mm



- 505-3004 .. Spoon Bent Gouge..... 04mm
- 505-3006 .. Spoon Bent Gouge..... 06mm
- 505-3008 .. Spoon Bent Gouge..... 08mm
- 505-3010 .. Spoon Bent Gouge..... 10mm
- 505-3012 .. Spoon Bent Gouge..... 12mm

Sweep #10

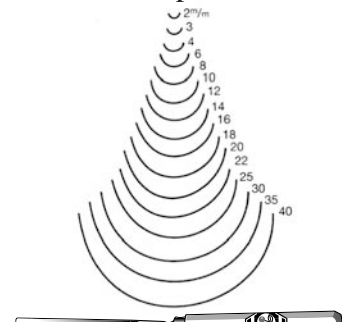

- 505-1002 Straight Gouge..... 02mm
- 505-1003 Straight Gouge..... 03mm
- 505-1004 Straight Gouge..... 04mm
- 505-1006 Straight Gouge..... 06mm
- 505-1008 Straight Gouge..... 08mm
- 505-1010 Straight Gouge..... 10mm
- 505-1012 Straight Gouge..... 12mm





CARVING TOOLS

- 505-1014 Straight Gouge..... 14mm
- 505-1016 Straight Gouge..... 16mm
- 505-1018 Straight Gouge..... 18mm
- 505-1020 Straight Gouge..... 20mm
- 505-1025 Straight Gouge..... 25mm
- 505-1030 Straight Gouge..... 30mm
- 505-1035 Straight Gouge..... 35mm



- 505-1906 Curved Gouge 06mm
- 505-1910 Curved Gouge 10mm
- 505-1912 Curved Gouge 12mm
- 505-1914 Curved Gouge 14mm
- 505-1916 Curved Gouge 16mm
- 505-1920 Curved Gouge 20mm
- 505-1922 Curved Gouge 22mm



- 505-3104 .. Spoon Bent Gouge..... 04mm
- 505-3106 .. Spoon Bent Gouge..... 06mm
- 505-3108 .. Spoon Bent Gouge..... 08mm
- 505-3110 .. Spoon Bent Gouge..... 10mm
- 505-3112 .. Spoon Bent Gouge..... 12mm
- 505-3116 .. Spoon Bent Gouge..... 16mm
- 505-3118 .. Spoon Bent Gouge..... 18mm

Sweep #11

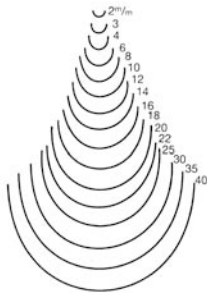

- 505-1102 Straight Gouge..... 02mm
- 505-1103 Straight Gouge..... 03mm
- 505-1104 Straight Gouge..... 04mm
- 505-1106 Straight Gouge..... 06mm
- 505-1108 Straight Gouge..... 08mm
- 505-1110 Straight Gouge..... 10mm
- 505-1112 Straight Gouge..... 12mm
- 505-1114 Straight Gouge..... 14mm
- 505-1116 Straight Gouge..... 16mm
- 505-1118 Straight Gouge..... 18mm
- 505-1120 Straight Gouge..... 20mm
- 505-1125 Straight Gouge..... 25mm
- 505-1130 Straight Gouge..... 30mm
- 505-1135 Straight Gouge..... 35mm



- 505-2006 Curved Gouge 06mm
- 505-2010 Curved Gouge 10mm
- 505-2012 Curved Gouge 12mm
- 505-2014 Curved Gouge 14mm
- 505-2016 Curved Gouge 16mm
- 505-2020 Curved Gouge 20mm
- 505-2025 Curved Gouge 25mm



- 505-3204 .. Spoon Bent Gouge..... 04mm
- 505-3206 .. Spoon Bent Gouge..... 06mm
- 505-3208 .. Spoon Bent Gouge..... 08mm
- 505-3210 .. Spoon Bent Gouge..... 10mm
- 505-3212 .. Spoon Bent Gouge..... 12mm
- 505-3216 .. Spoon Bent Gouge..... 16mm
- 505-3218 .. Spoon Bent Gouge..... 18mm

75° Degree V-Tool #39

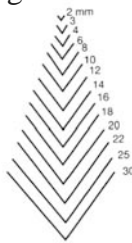

- 505-3902 ... Straight V-Chisel..... 02mm
- 505-3904 ... Straight V-Chisel..... 04mm
- 505-3906 ... Straight V-Chisel..... 06mm
- 505-3910 ... Straight V-Chisel..... 10mm
- 505-3914 ... Straight V-Chisel..... 14mm



- 505-4006 Curved V-Chisel 06mm
- 505-4012 Curved V-Chisel 12mm



- 505-4308 Spoon Bent V-Chisel..... 08mm

60° Degree V-Tool #41

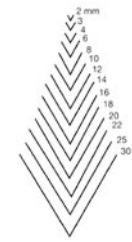

- 505-4102 ... Straight V-Chisel..... 02mm
- 505-4104 ... Straight V-Chisel..... 04mm
- 505-4106 ... Straight V-Chisel..... 06mm
- 505-4110 ... Straight V-Chisel..... 10mm
- 505-4114 ... Straight V-Chisel..... 14mm
- 505-4125 ... Straight V-Chisel..... 25mm



- 505-4206 Curve V-Chisel 06mm



- 505-4418 Spoon Bent V-Chisel..... 18mm

100° Degree V-Tool #45



- 505-4502 Straight V-Chisel 02mm
- 505-4504 Straight V-Chisel 04mm
- 505-4512 Straight V-Chisel 12mm



- 505-4616 Curved V-Chisel..... 16mm

Grooving Tools #47

- U 1 mm
- U 1 1/2
- U 2



- 505-4701 1.0mm
- 505-4715 1.5mm
- 505-4702 2.0mm

Macaroni Tool

- 6 mm
- 10
- 12
- 16



- 505-6006 06mm
- 505-6010 10mm
- 505-6012 12mm
- 505-6016 16mm

Swiss Pattern Fish Tail Tools



- 505-8150 50mm



- 505-8350 50mm



- 505-8650 50mm



- 505-8750 50mm

Carving Tool Handle



The same handle as used on the full-size Two Cherries carving tools. Size indicated is the width of tool which the handle generally fits.

- 505-0092 12 to 16mm
- 505-0093 18 to 22mm
- 505-0094 25 to 80mm

Professional Tool Sets

Twelve piece set is the start-up set, while the six piece set can be used as a beginning set, but is more useful as an add-on of larger tools to the twelve piece set.

Set of Twelve
505-0012

- 505-0114
- 505-0206
- 505-0514
- 505-0516
- 505-0603
- 505-0610
- 505-0706
- 505-0814
- 505-1102
- 505-1406
- 505-2103
- 505-3906

Set of Six
505-0006

- 505-0214
- 505-0616
- 505-0806
- 505-1114
- 505-1610
- 505-3914



TWO CHERRIES CARVING TOOLS

Small Carving Tools



These smaller Two Cherries carving tools are the same quality as the larger professional tools shown on the previous pages, but fill the need for the occasional carver, and the carver doing smaller work. These are professional quality, smaller tools, polished all around. The blades are about 4" long and the overall length with handle is about 8".

All of these tools come with an octagonal shaped handle that you will find easy to work with.

Straight Chisel Edge



- | | |
|-------------------|--------------------|
| 510-01022mm | 510-01088mm |
| 510-01044mm | 510-011010mm |
| 510-01066mm | |

Straight Skew Edge



- | | |
|-------------------|--------------------|
| 510-02022mm | 510-02088mm |
| 510-02044mm | 510-021010mm |
| 510-02066mm | |

Straight, Very Shallow Gouge - Sweep 6



- | | |
|-------------------|--------------------|
| 510-06022mm | 510-06088mm |
| 510-06044mm | 510-061010mm |
| 510-06066mm | |

Straight, Shallow Gouge Sweep 8



- | | |
|-------------------|--------------------|
| 510-08022mm | 510-08088mm |
| 510-08044mm | 510-081010mm |
| 510-08066mm | |

Straight Gouge Sweep 10



- | | |
|-------------------|--------------------|
| 510-10022mm | 510-10088mm |
| 510-10044mm | 510-101010mm |
| 510-10066mm | |

Curved, Very Shallow Gouge - Sweep 6



- | | |
|-------------------|--------------------|
| 510-15022mm | 510-15088mm |
| 510-15044mm | 510-151010mm |
| 510-15066mm | |

Curved, Shallow Gouge Sweep 8



- | | |
|-------------------|--------------------|
| 510-17022mm | 510-17088mm |
| 510-17044mm | 510-171010mm |
| 510-17066mm | |

Curved Gouge Sweep 10



- | | |
|-------------------|--------------------|
| 510-19022mm | 510-19088mm |
| 510-19044mm | 510-191010mm |
| 510-19066mm | |

Spoon Bent Straight Edge



- | | |
|-------------------|--------------------|
| 510-21022mm | 510-21088mm |
| 510-21044mm | 510-211010mm |
| 510-21066mm | |

Spoon Bent, Very Shallow Gouge - Sweep 6



- | | |
|-------------------|--------------------|
| 510-27022mm | 510-27088mm |
| 510-27044mm | 510-271010mm |
| 510-27066mm | |

Spoon Bent, Shallow Gouge - Sweep 8



- | | |
|-------------------|--------------------|
| 510-29022mm | 510-29088mm |
| 510-29044mm | 510-291010mm |
| 510-29066mm | |

Spoon Bent, Gouge Sweep 10



- | | |
|-------------------|--------------------|
| 510-31022mm | 510-31088mm |
| 510-31044mm | 510-311010mm |
| 510-31066mm | |

Straight V-Chisel 75°



- | | |
|-------------------|--------------------|
| 510-39022mm | 510-39088mm |
| 510-39044mm | 510-391010mm |
| 510-39066mm | |

Curved V-Chisel 75°



- | | |
|-------------------|--------------------|
| 510-40022mm | 510-40088mm |
| 510-40044mm | 510-401010mm |
| 510-40066mm | |

Spoon Bent V-Chisel 75°



- | | |
|-------------------|--------------------|
| 510-43022mm | 510-43088mm |
| 510-43044mm | 510-431010mm |
| 510-43066mm | |

Straight Grooving Gouge Sweep 11



- | | |
|-------------------|--------------------|
| 510-47022mm | 510-47088mm |
| 510-47044mm | 510-471010mm |
| 510-47066mm | |



Carving Project

Based upon our experience this set provides the necessary materials and tools for the beginning wood carver. The project set contains a semi-finished wooden dolphin and a set of basic woodcarving tools, including three carving knives and one 6mm shallow gouge. Specifically, three carving knives 515-3351, 515-3353, 515-3356 and shallow gouge 510-0606. This set is packaged in a nice presentation carton so that it is perfect for giving to the soon-to-be woodcarver! Whether this is a kit for yourself or for a friend - both the tools and the finished project will be cherished for years to come.

515-3439 Dolphin Carving Kit

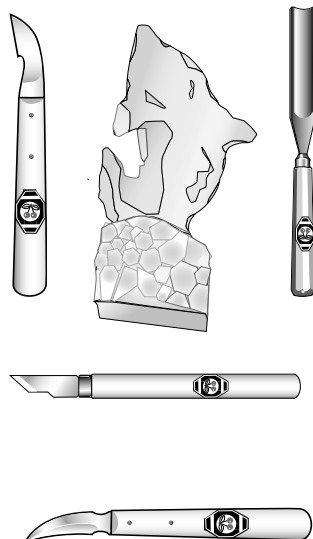

Four Piece Set



This four piece set is made to the highest standards of German quality by Two Cherries. This basic set contains a straight chisel (510-0108), medium gouge (510-0808), a V-chisel (510-3906) and chip carving knife (515-3352).

515-3424 Small Set of 4

Seven Piece Set



Great starter set comes with a straight chisel (510-0108), medium gouge (510-0806), V-chisel (510-3906), three chip carving knives (515-3351, 3353, 3358) and a sharpening stone! Perfect for the beginner woodcarver, or the woodworker that needs a few tools to use in adding carved details to their work.

515-3427 Small Set of 7



TWO CHERRIES PEAR HANDLED CARVING TOOLS

Pear Handled Carving Tools



For carvers who do mostly smaller work, where large amounts of wood are not being removed, these pear shaped handled chisels are perfect. The handle is shaped to be comfortable in the hand, and a flat on one side keeps the tool from rolling off the workbench. Each handle is protected with a high gloss finish. The blades are about 4" long and the overall length with handle is about 6 1/2".

These are the same blades found on the smaller octagon handled tools, and the blades keep to the exacting high standards found on all Two Cherries tools. Hand forged of high carbon steel, the blades are heat treated to sixty-one degrees Rockwell, and then ground and polished all around.

Straight Chisel Edge

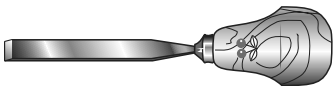

- | | |
|-------------------|--------------------|
| 511-01022mm | 511-01088mm |
| 511-01044mm | 511-011010mm |
| 511-01066mm | |

Straight Skew Edge



- | | |
|-------------------|--------------------|
| 511-02022mm | 511-02088mm |
| 511-02044mm | 511-021010mm |
| 511-02066mm | |

Straight, Very Shallow Gouge - Sweep 6

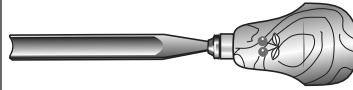

- | | |
|-------------------|--------------------|
| 511-06022mm | 511-06088mm |
| 511-06044mm | 511-061010mm |
| 511-06066mm | |

Straight, Shallow Gouge Sweep 8



- | | |
|-------------------|--------------------|
| 511-08022mm | 511-08088mm |
| 511-08044mm | 511-081010mm |
| 511-08066mm | |

Straight Gouge Sweep 10



- | | |
|-------------------|--------------------|
| 511-10022mm | 511-10088mm |
| 511-10044mm | 511-101010mm |
| 511-10066mm | |

Curved, Very Shallow Gouge - Sweep 6



- | | |
|-------------------|--------------------|
| 511-15022mm | 511-15088mm |
| 511-15044mm | 511-151010mm |
| 511-15066mm | |

Curved, Shallow Gouge - Sweep 8



- | | |
|-------------------|--------------------|
| 511-17022mm | 511-17088mm |
| 511-17044mm | 511-171010mm |
| 511-17066mm | |

Curved Gouge Sweep 10



- | | |
|-------------------|--------------------|
| 511-19022mm | 511-19088mm |
| 511-19044mm | 511-191010mm |
| 511-19066mm | |

Spoon Bent Straight Edge



- | | |
|-------------------|--------------------|
| 511-21022mm | 511-21088mm |
| 511-21044mm | 511-211010mm |
| 511-21066mm | |

Spoon Bent, Very Shallow Gouge - Sweep 6



- | | |
|-------------------|--------------------|
| 511-27022mm | 511-27088mm |
| 511-27044mm | 511-271010mm |
| 511-27066mm | |

Spoon Bent Shallow Gouge - Sweep 8

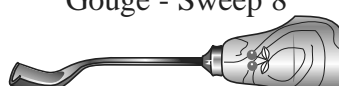

- | | |
|-------------------|--------------------|
| 511-29022mm | 511-29088mm |
| 511-29044mm | 511-291010mm |
| 511-29066mm | |

Spoon Bent, Gouge Sweep 10



- | | |
|-------------------|--------------------|
| 511-31022mm | 511-31088mm |
| 511-31044mm | 511-311010mm |
| 511-31066mm | |

Straight V-Chisel 75°



- | | |
|-------------------|--------------------|
| 511-39022mm | 511-39088mm |
| 511-39044mm | 511-391010mm |
| 511-39066mm | |

Curved V-Chisel 75°



- | | |
|-------------------|--------------------|
| 511-40022mm | 511-40088mm |
| 511-40044mm | 511-401010mm |
| 511-40066mm | |

Spoon Bent V-Chisel 75°

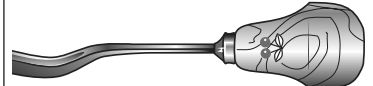

- | | |
|-------------------|--------------------|
| 511-43022mm | 511-43088mm |
| 511-43044mm | 511-431010mm |
| 511-43066mm | |

Straight Grooving Gouge Sweep 11

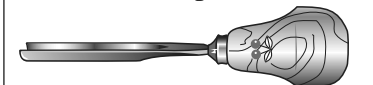

- | | |
|-------------------|--------------------|
| 511-47022mm | 511-47088mm |
| 511-47044mm | 511-471010mm |
| 511-47066mm | |



Carving Tool Set

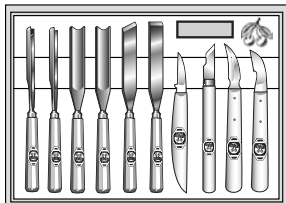

Ten Two Cherries carving tools along with a sharpening stone -- in a beautiful wooden storage box. Tools include gouges, skew, v-tool, and chip carving knives. This set will allow a wide variety of work to be performed, and is a great base upon which to build a larger collection of Two Cherries carving tools. It makes a splendid gift!

- 515-3441 11 Piece Set

Carving Tool Set



Handy set of seven high quality carving tools in a fitted wooden box. Set includes straight tool, medium gouge, V-chisel, three chip carving knives, and a sharpening stone. See item 515-3427 for exact specifications.

- 515-3437 Set of Seven in Wood Box

Pear Handled Set in Wooden Box

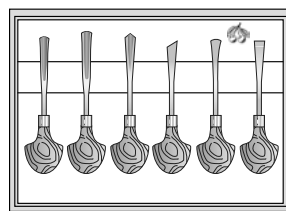

Set of six commonly used carving tools with pear shaped handles. Blades are honed and can be used immediately. This beautiful set comes in a fitted wooden box for storage between carving sessions. See item 511-0050 for exact specifications.

- 511-0100Set of Six in Wood Box

Pear Handled Set



Set of six commonly used carving tools with pear shaped handles. Chosen from the selection of pear shaped handled tools on this page. Blades are honed and can be used immediately. Also available in an attractive and highly functional fitted wooden box. Contains chisels 511-0102, 511-0106, 511-0110, 511-0606, 511-0610, and 511-3904.

- 511-0050 Set of Six



TWO CHERRIES CARVING TOOLS

Miniature Carving Tools

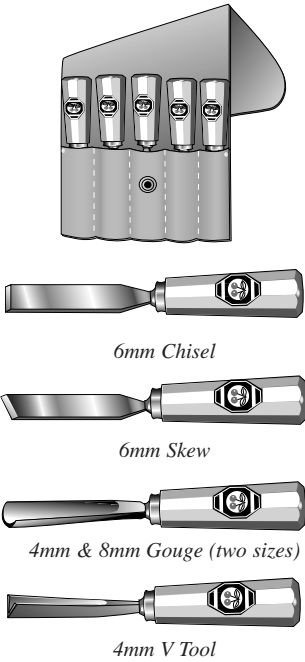

Have you ever needed a very small carving tool for working in limited access or on very small pieces of work? Two Cherries has provided the solution! Small octagon handles fit comfortably in the hand, and the balance of handle to blade is perfect. Still made in the same manner that makes all Two Cherries tools the finest in the world, with blades of high carbon steel, heat treated to take and hold an edge. Blades are approximately 2 1/4" long with overall tool length about 4 7/16". Item 515-8575 is illustrated above.

515-8500Set of Five (without case)
515-8575Set of Five in Leather Case



Headquarters for the Two Cherries factory in Remscheid, Germany. The factory is adjacent to this traditional shingled building.

Chip Carving Knives

As the name implies, these knives are perfect for chip carving work, but will find their way into all types of carving and woodworking crafts.

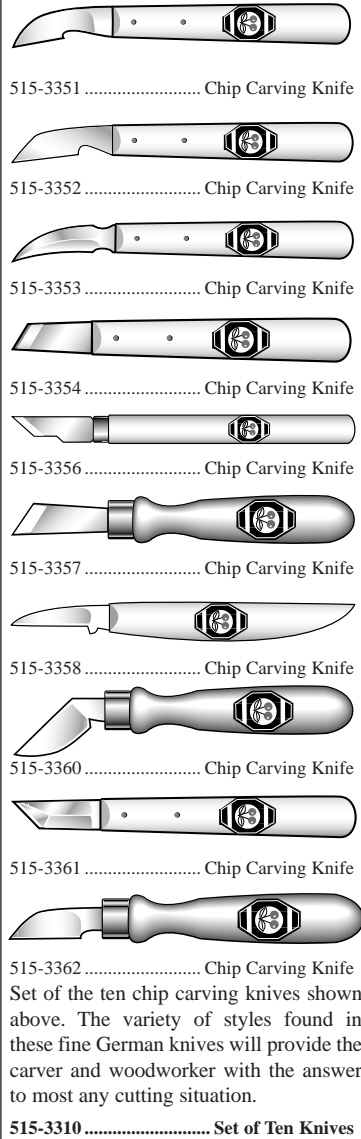

- 515-3351 Chip Carving Knife
- 515-3352 Chip Carving Knife
- 515-3353 Chip Carving Knife
- 515-3354 Chip Carving Knife
- 515-3356 Chip Carving Knife
- 515-3357 Chip Carving Knife
- 515-3358 Chip Carving Knife
- 515-3360 Chip Carving Knife
- 515-3361 Chip Carving Knife
- 515-3362 Chip Carving Knife



Similar to the 3358 knife above, but slightly smaller handle.
515-3363 Chip Carving Knife

Chip Carving Set

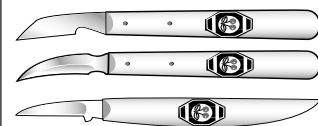

Set of three chip carving knives contains the popular models 515-3352, 515-3353, and 515-3358.
515-3303 Set Of Three

Micro Carving Tools

Like all other products made by Two Cherries, these tools are hand forged and finely polished. The blades are mounted on a specially designed wooden handle to give an easy-to-use feeling. The blades are approximately 60mm long on a handle of 110mm (about 170mm, or just under seven inches, overall). Fourteen different tools are available in either open stock or useful sets. These are the tools that woodcarvers have been looking for to work the details in their carving.

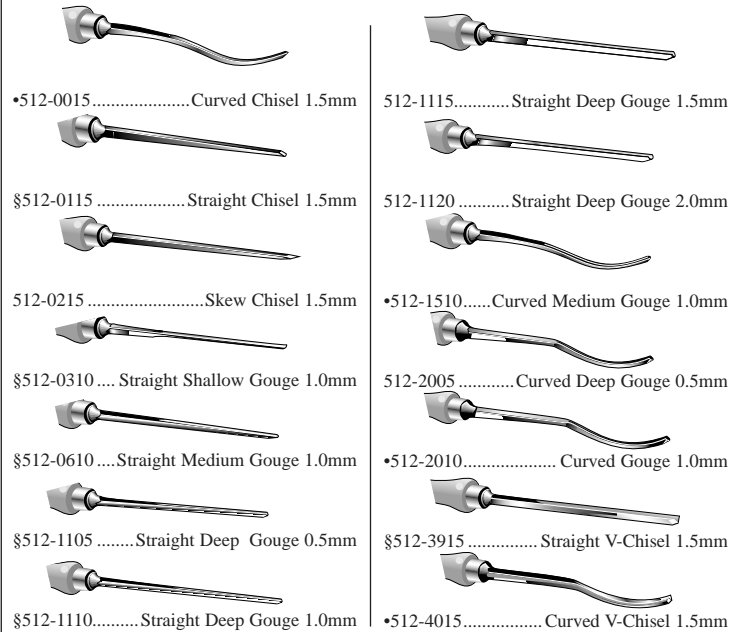

- *512-0015 Curved Chisel 1.5mm
- 512-1115 Straight Deep Gouge 1.5mm
- §512-0115 Straight Chisel 1.5mm
- 512-1120 Straight Deep Gouge 2.0mm
- §512-0215 Skew Chisel 1.5mm
- *512-1510 Curved Medium Gouge 1.0mm
- §512-0310 Straight Shallow Gouge 1.0mm
- 512-2005 Curved Deep Gouge 0.5mm
- §512-0610 Straight Medium Gouge 1.0mm
- *512-2010 Curved Gouge 1.0mm
- §512-1105 Straight Deep Gouge 0.5mm
- §512-3915 Straight V-Chisel 1.5mm
- §512-1110 Straight Deep Gouge 1.0mm
- *512-4015 Curved V-Chisel 1.5mm

Micro Carving Tool Sets

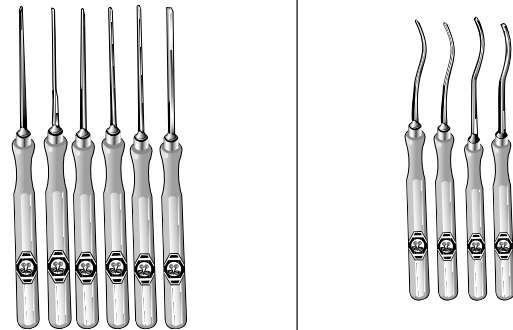

Set of six micro carving tools. Includes items marked § above.
512-5406 (Marked § above) Set of Six

Set of six micro carving tools. Includes items marked * above.
512-5404 (Marked * above) Set of Four

Micro Carving Tool Set in Wooden Box

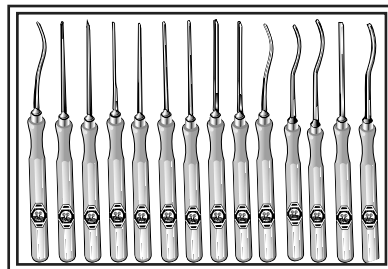

A complete set of fourteen micro carving tools in a fitted wooden box. With this complete set you can tackle most any small carving project that you can imagine!
512-5414 Set of Fourteen



TWO CHERRIES DRAWKNIVES & ACCESSORIES

Leather Apron

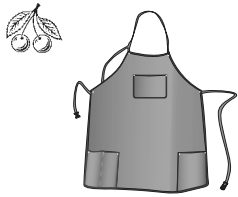

This quality leather apron is made for woodworkers. The velour leather not only provides good body protection, but it is also a long wearing apron. Made from durable materials, it has a fully adjustable nylon waist and adjustable neck straps, both with a quick-release buckle. Stress points are reinforced with rivets. The three bottom pockets and the top pocket are able to keep a variety of tools. The backside of the apron is covered with a black lining. The Two Cherries logo is embroidered on the front.

524-7100..... Two Cherries Leather Apron

Two Cherries Baseball Cap



Stylish, unique and a nod to your favorite chisels and carving tools. Fully adjustable, adult-sized cap.

524-7300..... Baseball Cap

Key Chain



This is the only tool in this series of small tools that does not have a sharp edge. Perfect gift for the woodworker that has everything. Use it for the key to the shop!

515-3250..... Keychain

Leather Tool Roll

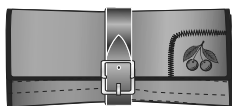

Made of the same high quality velour leather as the Leather Apron. The supple leather is soft and manageable and provides ideal protection for chisels and carving tools. It has 12 pockets and, when closed, it is secured by a belt-like strap. The Two Cherries logo is embroidered on the front.

524-7200..... Two Cherries Tool Roll

Bronze Head Mallets



The heavy, but compact bronze head mallet is ideal for striking use when a compact stroke or limited access area is being worked. Despite its size and weight, it is very controllable and lends itself to both full impact strikes as well as delicate tapping. Available in three weights and each comes with a storage pouch.

- 515-4380..... Bronze Mallet..... 380 Grams
- 515-4550..... Bronze Mallet..... 550 Grams
- 515-4750..... Bronze Mallet..... 750 Grams

Carver's Hook

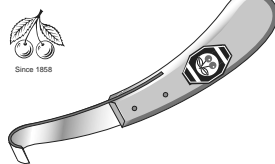

This can be an extremely helpful tool for working in hard-to-reach places of an intricate piece.

- 515-9710..... Right-hand
- 515-9715..... Left-hand
- 515-9720..... Combination

Woodcarvers' Screw

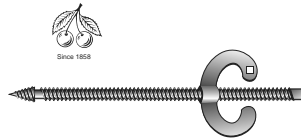

This is an exceptionally well made woodcarver's screw designed to hold projects to the bench top so that the carver has free access to the work from all sides.

515-3506..... Carver's Screw

Inshave



Inshave, with two handles, has a blade width of 170mm. Excellent to cut deep hollows for bowls and chair seats. The blade is carefully forged, heat treated, and ground. Two Cherries

500-2210..... Inshave

Scorp

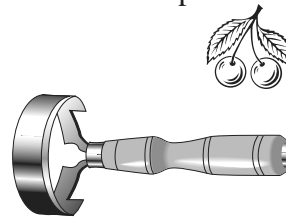

Scorp has a single handle, and smaller (3/2") diameter cutting shape and 1/4" blade width. Two Cherries

500-2250..... Scorp

Adze

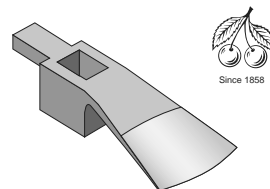

Two styles of adze are available. The flat lip adze has a cutting edge of just over 3", the curved lip adze just under 3". Both weigh approx. 2.5 pounds and come unhandled, order handle separately. Two Cherries

Blade Width	Style
500-1210..... 3/4"	Flat Edge
500-1250..... 2/2"	Curved Edge
500-1275..... 31"	Handle Only

Drawknives



Here is a selection of three drawknives from Two Cherries available in either a curved or a straight edge model. Forged to same high standards as their other tools, each model has a blade that is 1 5/16" wide and 3/16" thick and two solid wooden handles that are about 4" long and perfectly positioned for the task at hand.



500-1320..... 225mm Straight Edge



500-1350..... 140mm Curved Edge

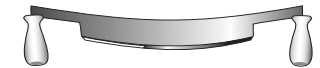

500-1370..... 225 Curved Edge

Millimeters to Inches

Millimeters	Inches
1.....	0.039
2.....	0.078
3.....	0.118
4.....	0.157
5.....	0.196
6.....	0.236
7.....	0.275
8.....	0.314
9.....	0.353
10.....	0.393
20.....	0.787
30.....	1.181
40.....	1.574
50.....	1.968
60.....	2.362

Inches to Millimeters

Inch	Millimeters
1/32.....	0.8
1/16.....	1.6
1/8.....	3.2
3/16.....	4.8
1/4.....	6.4
5/16.....	7.9
3/8.....	9.5
7/16.....	11.1
1/2.....	12.7

Two Cherries Sharpening DVD

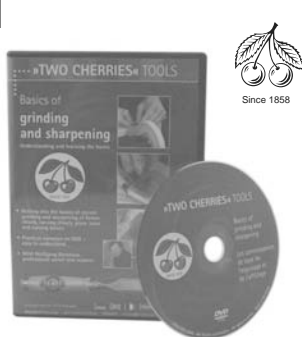

An instructional DVD from Two Cherries covering the sharpening of chisel and plane blades, as well as a wide range of carving tool sweeps and sizes, from 1mm micro gouges to 3" fishtail tools, V-tools, and more. The sharpening methods demonstrated use only easy to find sharpening equipment and shop-made jigs. The techniques do not require the use of hard to find or expensive equipment. The instructor also shows how to repair and restore a damaged cutting edge. DVD can be played in English, Spanish, German, Dutch, or French. Approximately 73 minutes.

524-7500..... Sharpening Video



TWO CHERRIES SCRAPERS SAWS & ACCESSORIES



Two Cherries
Scrapers and Burnishers



Two Cherries brand scrapers and burnishers are manufactured to the highest quality standards. For more than one hundred and fifty years this German brand has been known and respected.

Cabinet Scrapers

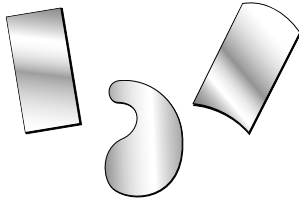

The finest German steel. Ideal tool for refinishers. Regular rectangle, curved on opposite ends, and the classic "gooseneck" shape. Set includes 0.8 mm rectangle, curved, and gooseneck scrapers with or without the oval burnisher. Use a burnisher to sharpen.

- 520-50050.6 mm Rectangle
- 520-50100.8 mm Rectangle
- 520-5060 Curved
- 520-5070 Gooseneck
- 520-5510Set of Scrapers (3)
- 520-5500Scrapers (3) & Burnisher

Burnishers



Oval Burnisher



Triangular Burnisher



Round Burnisher

Burnishers for sharpening hand and cabinet scraper blades. All styles include handle and are approximately 9 1/2" in overall length.

- 520-5080 Oval
- 520-5085 Triangular
- 520-5090 Round

Professional Scraper

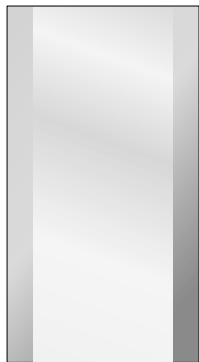

This Two Cherries scraper is specially prepared to let you get to work faster. The two long edges are square and have been worked so that they are smooth, without scratches that will end up showing on the wood surface. This saves you the tedious job of filing the edge square and then honing all the scratches from the area that you have just filed. With this scraper that part of the job has already been done, so just grab your burnisher and turn the edge.

- 520-5750Scraper with Prepared Edges

Scraper Wallet

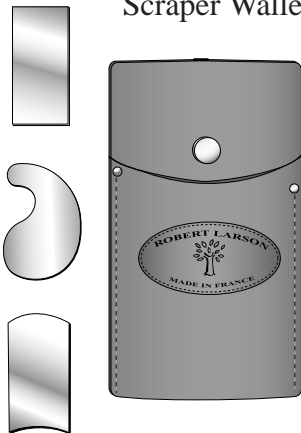

It's almost a wonder that this storage wallet wasn't thought of ages ago. This is the best way to store all of your flat metal scrapers. After spending so much time filing, then honing, and finally turning an edge with a burnisher — why ruin all that work by simply throwing your scraper into your workbox or stacked up in a pile of tools. This will protect all of your hard work. Internal dividers keeps each scraper from working against another. Available alone, or with three Two Cherries scrapers. Fits a maximum of five scrapers.

- 845-1050 Leather Scraper Wallet
- 520-5575 Wallet with Three Scrapers

Brass Back Dovetail Saws

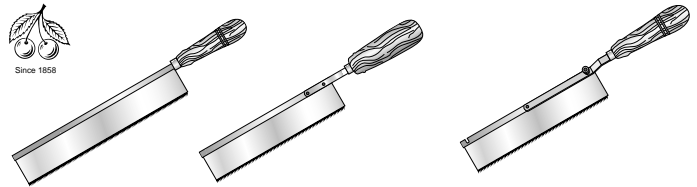

The stiffening back is made out of brass to add guiding weight and aesthetic joy. Highest quality German tool with 15 teeth per inch. Two Cherries

- 520-602010" Dovetail
- 520-605010" Offset Dovetail
- 520-608010" Reversible Dovetail

Dovetail Saws

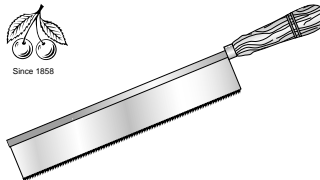

Steel backed dovetail saw of fine German workmanship. Straight, polished handle, set & sharpened. Saw is 250mm (9.6") long.

- 520-2020 Dovetail 15 tpi

Offset Dovetail Saws

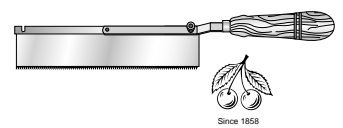

The finest German workmanship with polished cranked handle, set and sharpened teeth. Blade is offset to the steel stiffening back so flush cuts can be made (as in cutting off dowel pins, through mortises, etc.). Reversible handle styles allow greater access. Both saws are 250 mm (9.6") long. Two Cherries

- 520-2050Offset 15 tpi
- 520-2080Reversible 15 tpi

Veneer Cutter

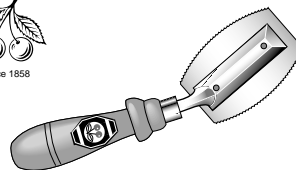

Veneer cutter with oval blade and offset handle. Cutting veneer with a knife leaves a beveled edge on the veneer cut whereas this tool makes a ninety degree cut of your veneer allowing a perfect joining of veneer pieces. Made in Germany.

- 520-2200 Veneer Cutter
- 520-2210 Replacement Blade
- 820-5100 Sharpening File (Not Two Cherries)

Awls

Mark the point where you will start to drill a hole, mark a line against a rule, or pierce a small hole in thin material. There are many uses in the shop for these awls.



- 520-1060 4 1/4" Blade.... 7 1/8" OA Germany

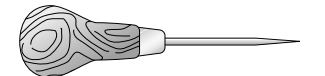

- 520-1050 2" Blade..... 4 7/8" OA Germany



Skilled craftsman forging a Two Cherries chisel.



Robert Larson Company
KELLER DOVETAIL SYSTEM

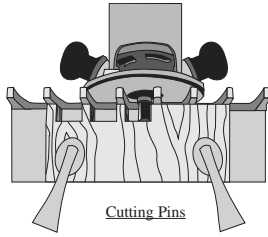

Cutting Pins

The
**KELLER
 DOVETAIL
 SYSTEM**

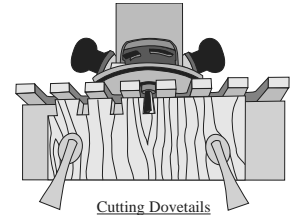

Cutting Dovetails

**Lets You Spend More Time Working With
 Wood, Less Time Adjusting Tools**

Because it is engineered for people who are not engineers, the Keller Dovetail System requires only your common sense and a router to get started. You simply clamp the Keller Dovetail Templates to your workpiece, pick up your router, and start cutting. In only 2 to 5 minutes you will cut both halves of a dovetail joint. The results will be clean, precise, and snug fitting, with beautiful hand-cut proportions

Lets You Cut Any Width Stock, and Vary Wood Thicknesses Easily...

All models give you through-dovetail joints in any width stock. Unlike other jigs, there are no built-in stops to limit the width of your work. If your work is wider than your templates, simply slide the templates along and continue cutting. Keller gives you a consistently tight dovetail joint regardless of the wood thickness or the router bit setting. All other jigs require time-wasting readjustments and test cuts every time you change your wood thickness. In addition, you can join wood of the same or different thicknesses with the same setup.

For Production Runs or Unique Heirlooms...

Classic or avant-garde project, Keller gives you strength, beauty, and speed. Each of the models has preset spacing especially designed in the classic proportions of handcut dovetails. Keller gives you these distinctive dovetail joints of traditional styling.

All Models Include . . .

Two precision templates (one only for The Journeyman models). Two carbide-tipped router bits (standard dimensions), one dovetail and one straight cutter. Two ball-bearing template guides, mounted on each router bit shank. Fully illustrated instruction manual for mounting and use. Each template requires a simple wooden backing block, not included. You can vary the spacing by merely shifting the location of the templates in between cuts, changing the size of the tails or pins, while easily maintaining excellent accuracy and beautiful proportions.

Journeyman Models

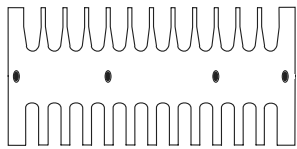

Journeyman Model 135-1500

This model is designed for joining smaller projects such as cabinets, drawers, jewelry boxes, and gift items. The double sided template comes with two router bits each with shank mounted bearings, and instructions.

- Wood Width Capacity:..... Unlimited
- Length of Templates:..... 15"
- Wood Thickness Capacity: 1/8"-3/4"
- with Rabbeted Pins:..... Up to 1"
- Dovetail Angle:..... 7 degree (8:1)
- Pin Spacing, center to center: 1 1/8"
- Minimum Router hp Required:..... 3/4hp
- Router Collet Size Required:..... 1/4"
- Shipping Weight:..... 2 lbs

Journeyman Model 135-2200

The larger 2200 model cuts dovetails for larger furniture, cabinets, casegoods, fixtures, and chests. The double sided template comes with two router bits each with shank mounted bearings, and instructions.

- Wood Width Capacity:..... Unlimited
- Length of Templates:..... 22"
- Wood Thickness Capacity: 1/4"-1"
- with Rabbeted Pins:..... Up to 1 1/2"
- Dovetail Angle:..... 7 degree (8:1)
- Pin Spacing, center to center: 1 3/4"
- Minimum Router hp Required:..... 1 1/4hp
- Router Collet Size Required:..... 1/2" or 3/8"
- Shipping Weight:..... 3 lbs

Professional Models

The templates of all three professional versions of the Keller Dovetail System are made of aluminum and designed to be real workhorses in the professional shop and factory.

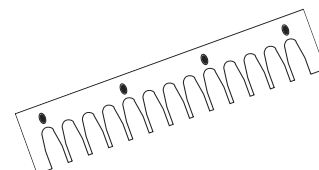
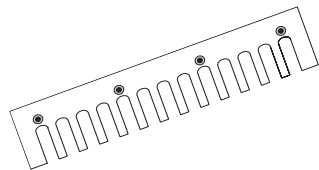

Professional Model 135-2401

Very popular midsize Keller Dovetail System model that was designed especially for furniture, cabinets, and casegoods. Comes with two aluminum templates, two router bits each with shank mounted bearings, and an instruction booklet.

- Wood Width Capacity:..... Unlimited
- Length of Templates: 24"
- Wood Thickness Capacity: 1/4"-1"
- with Rabbeted Pins:..... Up to 1 1/2"
- Dovetail Angle:..... 7 degree (8:1)
- Pin Spacing, center to center: 1 3/4"
- Minimum Router hp Required:..... 1 1/4hp
- Router Collet Size Required:..... 1/2" or 3/8"
- Shipping Weight:..... 8 lbs

Professional Model 135-1601

This model is designed for joining smaller projects, such as cabinets, drawers, jewelry boxes, and gift items. Comes with two aluminum templates, two router bits each with shank mounted bearings, and an instruction booklet

- Wood Width Capacity:..... Unlimited
- Length of Templates:..... 16"
- Wood Thickness Capacity: 1/8"-3/4"
- with Rabbeted Pins:..... Up to 1"
- Dovetail Angle:..... 7 degree (8:1)
- Pin Spacing, center to center:..... 1 1/8"
- Minimum Router hp Required:..... 3/4hp
- Router Collet Size Required:..... 1/4"
- Shipping Weight:..... 5 lbs

Model 135-3600

Industrial workhorse scaled for larger furniture, cabinets, casegoods, fixtures & chests. Improved version of the original Keller Dovetail Template. Comes with two aluminum templates, two router bits each with shank mounted bearings, and an instruction booklet.

- Wood Width Capacity:..... Unlimited
- Length of Templates:..... 36"
- Wood Thickness Capacity: 1/2"- 1 1/4"
- with Rabbeted Pins:..... Up to 1 1/2"
- Dovetail Angle:..... 14 degree (4:1)
- Pin Spacing, center to center: 3"
- Minimum Router hp Required:..... 1 1/2hp
- Router Collet Size Required:..... 1/2"
- Shipping Weight:..... 13 lbs

**Bits & Bearings for the 1500 & 1601
 (with diameter and carbide height)**

- Standard Dovetail (7/16" x 3/4")..... 135-1633
- Standard Straight (5/8" x 3/4")..... 135-1643
- Standard Set..... 135-1695
- Optional Dovetail (11/32" x 3/8")..... 135-1631
- Optional Straight (5/8" x 1/2")..... 135-1641
- Optional Set 135-1690
- Box Joint Bit..... 135-1642
- Bearing for all bits above..... 135-7225

**Bits & Bearings for the 2200 & 2401
 (with diameter and carbide height)**

- Standard Dovetail (5/8" x 1")..... 135-2435
- Standard Straight (7/8" x 1")..... 135-2445
- Standard Set..... 135-2495
- Optional Dovetail (7/16" x 3/4")..... 135-2433
- Optional Straight (5/8" x 3/4")..... 135-2443
- Optional Set 135-2490
- Box Joint Bit..... Use 135-2445
- Bearing for 135-2433..... 135-7227
- Bearing for 135-2443..... 135-7225
- Bearing for all other bits..... 135-7237
- Collet Adapter 3/8" - 1/2"..... 135-2425

**Bits & Bearings for the 3600
 (with diameter and carbide height)**

- Standard Dovetail (1" x 1")..... 135-3637
- Standard Straight (7/8" x 1")..... 135-3645
- Standard Set..... 135-3690
- Optional Dovetail (1 1/8" x 1 1/4")... 135-3639
- Optional Straight (7/8" x 1 1/4")..... 135-3649
- Optional Set..... 135-3695
- Box Joint Bit..... Use 135-3645
- Bearing for 135-3637 & 3639 135-7249
- Bearing for 135-3645 & 3649 135-7237

**Dovetail System
 Video & Instruction Book**

- The Keller Dovetail System Video and Instruction Book show step-by-step demonstrations of the system's basic operation, plus an overview of its other capabilities.
- 135-8000 VHS
 - 135-8500 DVD
 - 135-0026 Instruction Book



THE RAMIA LINE OF WORKBENCHES

ADVANCED WORKBENCHES



Advanced 1500 Workbench
List: \$535.00
SKU: 975-1000



Advanced 2000 Workbench
List: \$599.00
SKU: 975-1200

Manufactured in the town of Pisek, located in the South Bohemian Region of the Czech Republic which has a century long tradition of producing high-quality Workbenches for both Professionals and Hobbyists alike. Ramia is a family business, sourcing the best quality FSC woods to make top-notch workbenches for the past decade.

They produce three different lines to suit most shops and budgets. The premium benches are beautifully made from FSC Beech wood, and perfect for a professional workshop. The Advanced series, made from block laminated Beech wood is an affordable bench for hobbyists and professionals with limited space. The Diamond series is a budget friendly bench but with a solid Beech top, making it a fantastic choice.

DIAMOND WORKBENCHES



Diamond 1500 Workbench
List: \$629.00
SKU: 975-1400



Diamond 1800 Workbench
List: \$689.00
SKU: 975-1600

We know that the Ramia line of workbenches will be a great addition to any workshop.

PREMIUM WORKBENCHES



Premium Plus Workbench
List: \$1,199.00
SKU: 975-2000



Premium Monster
List: \$1,799.00
SKU: 975-2200



Premium Star Workbench
List: \$1,299.00
SKU: 975-2400

CUPBOARDS FOR ADVANCED OR DIAMOND BENCH



Hobby Cupboard I
List: \$210.00
SKU: 975-1700



Hobby Cupboard II
List: \$289.00
SKU: 975-1900



Pro Cupboard I
List: \$369.00
SKU: 975-2500



Pro Cupboard II
List: \$505.00
SKU: 975-2700

CUPBOARDS FOR PREMIUM BENCHES

Order	Description	Ramia	Length Inches	Width Inches	Height Inches	Weight Pounds
975-1000	ADVANCED 1500 WORKBENCH	HB-N1500	54	21	4	103
975-1200	ADVANCED 2000 WORKBENCH	HB-N2000	74	21	4	114
975-1400	DIAMOND 1500 WORKBENCH	HB-D1500	56	25	4	110
975-1600	DIAMOND 1800 WORKBENCH	HB-D1800	67	25	4	132
975-1700	CUPBOARD FOR ADVANCED OR DIAMOND BENCH	HB-I	41	21	4	55
975-1900	CUPBOARD FOR ADVANCED OR DIAMOND BENCH	HB-II	41	18	20	66
975-2000	PREMIUM PLUS WORKBENCH	PRO-AS	87	26	8	200
975-2200	PREMIUM MONSTER WORKBENCH	PRO-ASM	87	26	8	213
975-2400	PREMIUM STAR WORKBENCH	PRO-AN	75	25	8	198
975-2500	CUPBOARD FOR PREMIUM BENCHES	PRO-I	50	22	4	62
975-2700	CUPBOARD FOR PREMIUM BENCHES	PRO-II	48	20	19	88



**Metric Brad Point Drills
High Speed Steel**

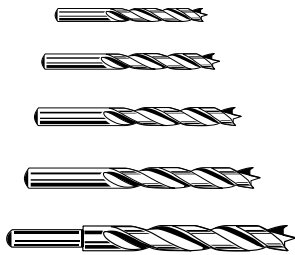

Excellent quality High Speed Steel wood-working bits. These have straight shanks to 10mm. Sizes larger than 10mm have 10mm shanks. Stern - Austria.

	Diameter	Length
570-70202mm48mm
570-70303mm70mm
570-70404mm80mm
570-70505mm90mm
570-70606mm100mm
570-70676.75mm110mm
570-70707mm110mm
570-70757.5mm115mm
570-70808mm115mm
570-70909mm125mm
570-710010mm130mm
570-711011mm140mm
570-712012mm140mm
570-713013mm140mm
570-714014mm140mm
570-715015mm140mm

Plug & Tenon Mill



If you are cutting plugs on a daily basis -- lots of plugs -- then this tool is the answer to your question, "Why doesn't someone make a great plug cutter?". Super heavy duty, suitable for making very long plugs or cutting round tenons. Made in Austria by Stern.

570-80063/8"	570-80161"
570-80081/2"	570-80201 1/4"
570-80123/4"	570-80221 3/8"
570-80147/8"		

**Plug Cutter
Tube Type**

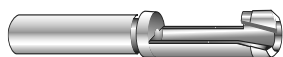

This tool is designed to eject a plug up to one inch long. Easy cutting and well made tool, this can speed up production of plugs significantly. Made in Austria by Stern.

570-85063/8"	570-85161"
570-85081/2"	570-85201 1/4"
570-85123/4"	570-85221 3/8"
570-85147/8"		



Carbide Tipped Bits

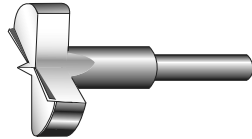

Drilling tools with carbide tipped cutting edges. Several sizes (especially 35mm) are essential for mounting adjustable hidden hinges. Overall length of 60mm.

570-202020mm	570-203030mm
570-202222mm	570-203232mm
570-202424mm	570-203434mm
570-202525mm	570-203535mm
570-202626mm	570-204040mm
570-202828mm		

Countersink



Yes, this looks different than the countersinks that you are used to, but the results are much better! This tool shears the wood rather than scraping the wood, and the results will make you wish that you had found this tool sooner. Wood Magazine calls this "The best countersink bits I've ever seen". Stern - Austria.

570-9216Up to 16mm holes
570-9220Up to 20mm holes

Clockmakers Bit



Three inch bit for installing clockworks. This bit has a 1/2" shank and is 5 1/2" overall length. For drill press only. Maximum speed of 400 RPM for softwoods and 300 RPM for hardwoods.

570-6000Clockmaker's Bit
----------	-----------------------

Adjustable Bit



A fine quality tool that does a good job of producing those intermediate diameter holes not possible with standard size drills. Design is configured like a universal bit to give the cleanest hole possible from this type drill.

Diameter	Length	Cutters	
570-570022-50mm140mmSteel
570-575022-50mm140mmCarbide
570-580034-80mm150mmSteel
570-585034-80mm150mmCarbide

Metric Forstner Bits

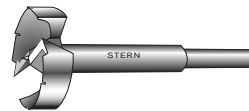

Made to the same very high quality as our inch size forstner bits. Because they are rim guided you can bore any arc of a circle. With the increasing popularity of European hardware these metric sizes are becoming very important. Overall length of 90mm.

570-510010mm	570-528028mm
570-511011mm	570-530030mm
570-512012mm	570-532032mm
570-513013mm	570-534034mm
570-514014mm	570-535035mm
570-515015mm	570-536036mm
570-516016mm	570-538038mm
570-517017mm	570-540040mm
570-518018mm	570-542042mm
570-520020mm	570-544044mm
570-522022mm	570-545045mm
570-524024mm	570-546046mm
570-525025mm	570-548048mm
570-526026mm	570-550050mm
570-527827.8mm		

Universal Bits

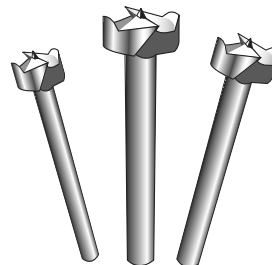

Makes a smooth, flat bottomed hole like a forstner bit, but with a really important difference. These bits are machine sharpenable! No more hand sharpening. These bits are top quality, high carbon steel.

570-35041/4"	570-35201 1/4"
570-35063/8"	570-35221 3/8"
570-35081/2"	570-35241 1/2"
570-35103/4"	570-35261 5/8"
570-35127/8"	570-35281 3/4"
570-35141"	570-35301 7/8"
570-35161 1/8"	570-35322"
570-35181 1/4"	570-35342 1/8"

In 1919 Michael Strasek introduced the trademark "Stern". Today, the company is run by the fourth generation of the founders family.

Forstner Bits

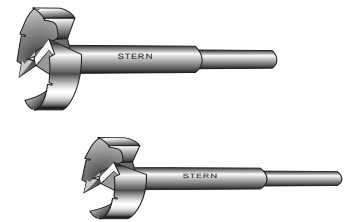

Drawing upon years of experience in making the highest quality forstner bits available, the Stern bit has been redesigned to include a tooth-like pattern on the outside rim of the tool. These teeth assist in the cutting action, and yet still offer the same advantages of the traditional forstner bit. These bits are guided by their circular rim instead of their center, and consequently will bore any arc of a circle and can be guided in any direction regardless of grain or knots. Bore a flat bottom hole. Set of five sizes indicated by *, set of eight sizes by +.

570-30051/4"	570-30191 3/16"
570-3006*+ 3/8"	570-3020*+ 1/4"
570-30077/16"	570-30211 1/16"
570-3008*+ 1/2"	570-30221 3/8"
570-30099/16"	570-30231 7/16"
570-3010+ 5/8"	570-3024+ 1 1/2"
570-30111 1/16"	570-30251 9/16"
570-3012*+ 3/4"	570-30261 5/8"
570-30131 3/16"	570-30271 11/16"
570-3014+ 7/8"	570-30281 3/4"
570-30151 5/16"	570-30291 13/16"
570-3016*+ 1"	570-30301 7/8"
570-30171 1/16"	570-30311 9/16"
570-30181 3/8"	570-30322"

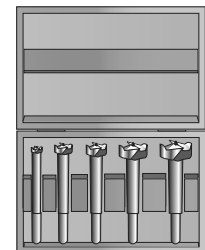

Set of 5 Forstner Bits includes sizes 3/8", 1/2", 3/4", 1", 1 1/4".

570-3100Set of 5

Set of 8 Forstner Bits includes sizes 3/8", 1/2", 5/8", 3/4", 7/8", 1", 1 1/4", 1 1/2".

570-3150Set of 8

Forstner Bit Extension

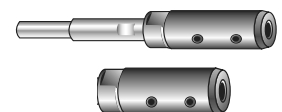

Three piece extension set for our already very useful forstner bits. Fits inch size forstners and multi-spur bits found in this catalog. Adds about 3 1/2" to drill.

570-3004 Extension for 3/16" & 3/8" Shanks



Self-Centering Drill Bits

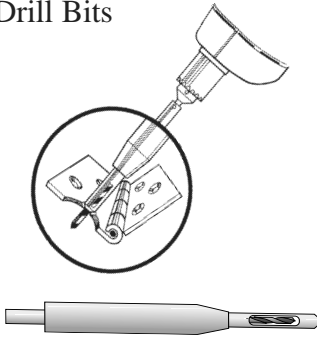

Speedy, accurate drilling tool with self-centering abilities. Saves hours of time drilling holes for hinges, striker plates—all hardware using screws. Save even more time with hex shank bits for screwguns. Denim case conveniently holds bits 305-0995, 1000, 1005. Made in the USA.

Bit # Fits screw size

305-0995	#3	#2 #3
305-1000	#5	#5 #6
305-1070	#7	#7
305-1005	#9	#8 #9 #10
305-1010	#12	#12
305-1015	#14	#14
305-3003	#3 Hex Shank	#2 #3
305-3005	#5 Hex Shank	#5 #6
305-3009	#9 Hex Shank	#8 #9 #10
305-2050	Vix Bit 5mm	
305-2100	Vix Bit 1/4"	

Replacement Parts = 305-xxxx

#	Guide	Drill	Spring	Washers	Set Screw
3.....	0997	0996	0998	1004	0100
5.....	1002	1001	0998	1004	0100
7.....	1072	1071	1008	1009	0100
9.....	1007	1006	1008	1009	0100
12.....	1012	1011	1013	1014	0105
14.....	1017	1016	1013	1014	0105
5 mm	---	2055	---	---	---
1/4"	---	2105	---	---	---
170-2450	---	---	---	3 Pocket Denim Case	---

Plug Cutters

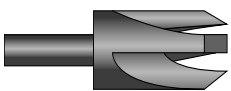

Designed for clean cutting and hardened for long life. Tool cuts fast and makes a smooth chamfered plug for easy starting in counterbored hole. USA.

355-3040	1/4"
355-3050	3/16"
355-3060	3/8"
355-3070	7/16"
355-3080	1/2"
355-3090	9/16"
355-3100	5/8"
355-3120	3/4"
355-3140	7/8"
355-3160	1"
355-3180	1 1/8"
355-3200	1 1/4"
355-3220	1 3/8"
355-3240	1 1/2"

Hex Shank Countersinks



Each countersink combination has a HSS tapered drill bit, countersink and stop collar. In one drilling application the tapered bit and the countersink will create the correct pilot hole for a wood screw. The hex drive allows for a secure grip in drill chucks. Select the bit size to match drilling needs. Generally, it is helpful to have more than one size in order to match different screw sizes.

357-4050	#5 with Hex Shank
357-4060	#6 with Hex Shank
357-4070	#7 with Hex Shank
357-4080	#8 with Hex Shank
357-4090	#9 with Hex Shank
357-4100	#10 with Hex Shank

Plug Cutters



Plug cutters are the only cutting tool which allows you to make wood plugs to fill-in drilled holes. Ideally, use the same wood as the project to make plugs, the holes will almost disappear when filled with matching plugs. See chart on this page for the plug cutters that match the counterbore of the countersinks above.

357-3060	3/8" with Hex Shank
357-3080	1/2" with Hex Shank

Stop Collars

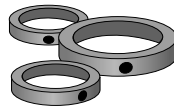

Use these stop collars on the countersinks above. Stop collars provides the operator control over how deep to drill. The collar is easy to use, simply slide it on the countersink and tighten with a hex wrench.

357-7060	3/8"
357-7080	1/2"

Replacement Taper Drills



Tapered to match screws sizes and perfect for drilling sized pilot holes which maximize thread grip along the full length of the screw. For use with the Fuller TPS adapter that comes with the countersinks above.

357-5050	HSS Taper Drill Only 1/8" (#5)
357-5060	HSS Taper Drill Only 9/64" (#6)
357-5070	HSS Taper Drill Only 5/32" (#7)
357-5080	HSS Taper Drill Only 11/64" (#8)
357-5090	HSS Taper Drill Only 3/16" (#9)
357-5100	HSS Taper Drill Only 13/64" (#10)

All of the items in the column above come in point-of-purchase packaging.

Countersink Drills

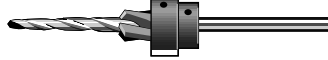

Drills the hole for the threaded and shank portion of wood screw, countersink for bevel under head, and if required, counterbore for wood plug. Complete with countersink, taper drill, & stop collar. All parts available separately. Size indicates wood screw sizing. Made in USA. Replacement parts are shown on this page.

Cs Complete	Screw Size	Cs
355-4030	3	1/4"
355-4040	4	3/16"
355-4050	5	3/8"
355-4060	6	3/8"
355-4070	7	3/8"
355-4080	8	3/8"
355-4090	9	3/8"
355-4100	10	7/16"
355-4120	12	1/2"
355-4140	14	1/2"
355-4160	16	3/4"
355-4180	18	5/8"

Countersink & Drill Sets

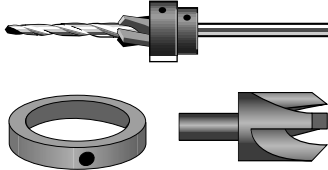

Set containing sizes 5 to 12 countersinks, drills, and stop collars comes in a special wooden block.

355-4000Set/7
Contains four drills, four countersinks, one each stop collar and plug cutter.

355-4010#5 Set
Contains five countersinks, five taper drills and two each plug cutters and stop collars in hardwood case.

355-4015#8 Set

Countersink Stop Collars

355-7040	1/4"
355-7050	5/16"
355-7060	3/8"
355-7070	7/16"
355-7080	1/2"
355-7100	3/4"
355-7140	7/8"
355-7160	1"

Countersink Drill Parts



Taper drills are available in regular length or long length. The countersinks (CS) do not come with stop collars, which are found elsewhere below. Made in USA.

Regular Length Taper Drills

Item	Fits CS	Item	Fits CS
355-5030	3	355-5100	10
355-5040	4	355-5120	12
355-5050	5	355-5140	14
355-5060	6	355-5160	16
355-5070	7	355-5180	18
355-5080	8	355-5190	24
355-5090	9	355-5200	7/16" Drill

Long Length Taper Drills

Item	Fits CS	Item	Fits CS
355-5035	3	355-5095	9
355-5045	4	355-5105	10
355-5055	5	355-5125	12
355-5065	6	355-5145	14
355-5075	7	355-5165	16
355-5085	8	355-5185	18

Countersink Only

Countersink	Screw Size	Plug Only
355-6030	3	1/4"
355-6040	4	3/16"
355-6050	5	3/8"
355-6060	6	3/8"
355-6070	7	3/8"
355-6080	8	3/8"
355-6090	9	3/8"
355-6100	10	7/16"
355-6120	12	1/2"
355-6140	14	1/2"
355-6160	16	3/4"
355-6180	18	5/8"
355-4991	---	Set Screw
355-4992	---	Allen Wrench

Drill Stop Collars



These collars are precision machined from solid bar stock, cold-rolled steel, and are balanced carefully. Set contains five collars 1/4" to 1/2" by 16ths of an inch. Made in USA.

355-7205	Set/5
355-7040	1/4"
355-7050	5/16"
355-7060	3/8"
355-7070	7/16"
355-7080	1/2"
355-7100	3/4"
355-7120	3/4"
355-7140	7/8"
355-7160	1"

Countersink Sizing Table

Size	Setscrew	Counterbore Diameter	Counterbore OL	Drill Size
3	1/8"	3/4"	3/4"	3/32"
4	3/16"	5/16"	7/8"	7/64"
5	3/16"	3/8"	7/8"	1/8"
6	3/16"	3/8"	7/8"	9/64"
7	3/16"	3/8"	7/8"	5/32"
8	3/16"	3/8"	7/8"	11/64"
9	3/16"	3/8"	7/8"	7/16"
10	1/4"	7/16"	7/8"	13/64"
12	1/4"	7/16"	7/8"	9/32"
14	1/4"	1/2"	7/8"	1/4"
16	3/16"	3/4"	1 1/16"	9/32"
18	5/16"	5/8"	1 1/16"	5/16"



DRILLING TOOLS & VISES

Brace

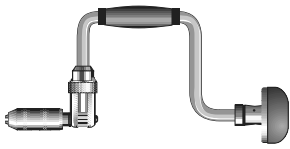

This is an extremely high quality brace with a three jaw chuck that will securely grip round shank drills and hex shank tools. When using a traditional auger bit, the end of the bit sits in a square hole in the bottom of the chuck -- that bit is not going to spin for any reason. Ratchet mechanism allows the brace to work in confined spaces with ease. Many woodworkers find that this old-fashioned tool is not something easily replaced in this modern world! Made in France.

838-4000 10" Brace - Three Jaws

Jennings Pattern Auger Bits



These are the highest quality auger bits available -- and live up to those made a generation and more ago. These bits are well balanced with a fast clearing action preferred by furniture makers and craftsmen. The bits are eight to ten inches in overall length. Two cutting spurs cut the fibers of the wood as the screw thread tip pulls the bit through the wood. Made in England.

635-7904 1/4"	635-7912 3/4"
635-7906 3/8"	635-7914 7/8"
635-7908 1/2"	635-7916 1"

Spiral Ratchet Screwdriver



For generations of woodworkers the spiral ratchet screwdriver was a must have tool. This screwdriver will drive and remove screws quickly and is as useful today as it was when it was first introduced. The spiral ratchet mechanism can be set to clockwise or counter-clockwise rotation, and even locked in place for extra turning power. These two models accept standard 1/4" insert bits so that you can work with any type of fastener. Made in Germany.

538-1335 335mm Screwdriver
538-1480 480mm Screwdriver



Also available are phillips replacement bits -- special alloy for long life. Length of 50mm (about 2") is perfect for the ratchet screwdrivers.

538-2131 #1
538-2132 #2
538-2133 #3

Hand Drills

Hand drills offer more than just slower RPMs. They provide control, safety and management of woods prone to splintering. These are quality hand drills meant for real work and for everyone, from students to seasoned craftsmen.

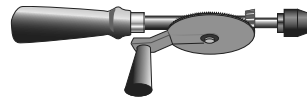

This 1/4" drill has a quality three-jaw chuck, smooth gears and a comfortable wood handle. Overall length is 9 1/4". Made in Germany.

538-3010 1/4" Capacity

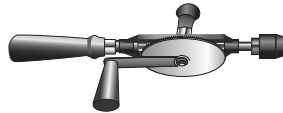

Similar to 538-3010, this 5/16" sturdy drill offers a thick casting and smooth running single pinion gearing. Overall length is 11". Made in Germany.

538-3030 5/16" Capacity

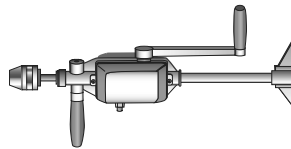

This Heavy-Duty 3/8" hand drill features a three-jaw chuck, chest plate, metal casing around the gears, polished finish and two speeds. The crank and side handles are wood. Overall length is 13 1/2". Made in Germany.

538-3050 Breast Drill 3/8" Capacity

Gimlets

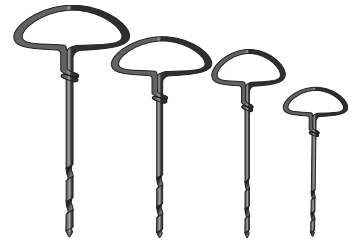

No need to find an electrical outlet! These high quality tools are hardened to the end of the flute, and the screw thread is specially annealed to make sure that it is not easily broken. The double spiral flutes are machined, rather than twisted, and will quickly and easily allow wood chips to clear the hole. Keep a set in the house, in the kitchen, and with your garden tools. An inexpensive, traditional, and extremely useful tool! Made in France.

849-3050 3mm
849-3060 4mm
849-3070 5mm
849-3080 6mm
849-3099 Set of Four Gimlets

Hand Countersink

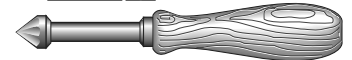

Handy and quick, this beautifully made countersink is a tool every woodworker should have. Easy to control and very high-quality with seven flutes for exceptionally smooth countersink boring. Overall length of 150mm, with wooden handle. Stern - Austria.

570-6100 16mm

Bench Stops

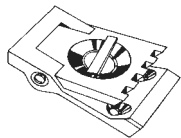

This bench stop will increase the size of materials that can be handled on your bench. Body is made aluminum to prevent damage to your tools.

800-1900 Bench Stop

Holdfast

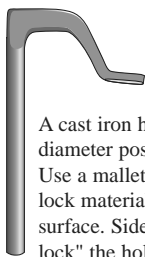

A cast iron holdfast with an 11/16" diameter post and a reach of 31/2". Use a mallet and a vertical blow to lock material tight against the bench surface. Sideways blows will "unlock" the holdfast.

800-3700 Bench Holdfast

Bench Dogs



Two styles of bench dogs. The square dogs are 3/4" x 5/8" across and 6 3/4" long. The brass face on the square dog is 1" x 5/8". The round dogs are 3/4" in diameter and constructed of solid brass. Clamping face on the round dog is 1/4" x 1 1/16".

825-6325 Round Bench Dogs (Pair)
825-6350 Square Bench Dogs (Pair)

Quick Release Vise with Dog

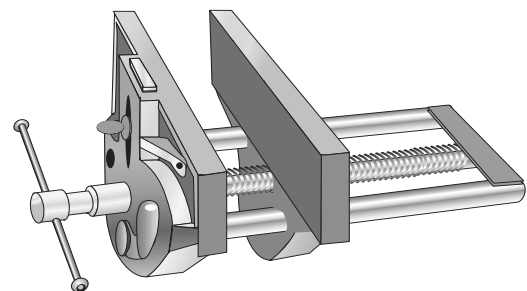

These efficient steel bench vises have time saving quick release mechanisms for the rapid movement of the vise jaw. Additionally, all have adjustable bench dogs. All models mount to the workbench edge and are fastened from underneath the bench. The 7 1/2" model requires approximately 12" of space under the bench and the 9" requires approximately 18". There are holes through the vise jaws so that they can be lined with wood faces. The 7 1/2" vise opens approximately 8" and the 9" vise opens approximately 13". Made in India by Anant.

896-5200 7 1/2" Wide Vise
896-5250 9" Wide Vise
896-5300 10 1/2" Wide Vise



FILES - RASPS - SANDING

Hand Cut Rasps

These rasps are made to the highest level of quality. Hand cut by journeymen file and rasp makers, these rasps are made the original way in a small workshop in Portugal. Far superior to typical machine made rasps, these are appreciated by all fine workers in wood, especially by patternmakers.



- 820-1500Cabinet Rasp 150mm Cut 5
- 820-1510Cabinet Rasp 200mm Cut 5
- 820-1520Cabinet Rasp 250mm Cut 5
- 820-1530Cabinet Rasp 300mm Cut 5

Not Illustrated

- 820-1610 Hand Rasp 200mm Cut 5

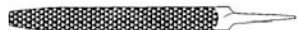

- 820-1710 .. Half Round Rasp 200mm Cut 5

Not Illustrated

- 820-1810 Round Rasp 200mm Cut 5

Cabinet Files & Rasps



Essential for all woodworkers. We offer a broad selection of both cabinet files and cabinet rasps. These are quality machine cut tools, made in Portugal.

- 555-1320 8" Cabinet File
- 555-1340 10" Cabinet File
- 555-1360 12" Cabinet File
- 555-1520 6" Round 2nd Cut
- 555-1540 8" Round 2nd Cut
- 555-1560 10" Round 2nd Cut
- 555-1620 8" Cabinet Rasp Regular
- 555-1640 8" Cabinet Rasp Smooth
- 555-1720 10" Cabinet Rasp Regular
- 555-1740 10" Cabinet Rasp Smooth
- 555-1820 12" Cabinet Rasp Regular



- 820-1050 Four Way Rasp+File 150mm

Abrasive Cleaner

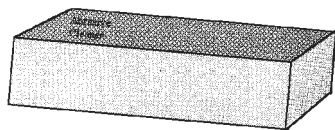

Inexpensive abrasive cleaning blocks that will lower your abrasive budget the first time they are used. Essential for anyone using abrasives on power equipment.

- 222-2000 1 1/2" x 1 1/2" x 8"

Saw Files



High quality machine cut saw file. This selection should offer a file for virtually any typical Western hand saw. Made in Portugal

- 555-1120 7" Regular
- 555-1140 7" Extra Slim
- 555-1160 6" Extra Slim
- 555-1180 6" Double Extra Slim
- 555-1190 5" Extra Slim
- 555-1200 4" Extra Slim
- 555-1220 4" Double Extra Slim

Mill Files



Single-cut mill files are used by the woodworker in sharpening both the saw and cabinet scraper. Very high quality machine cut tool. Made in Portugal

- 555-1000 6" Second Cut
- 555-1010 8" Second Cut
- 555-1020 10" Second Cut

Saw Files



These 'feather edge' files are essential for maintaining the cutting edge of Japanese saws. Two sizes are available.

- 740-1010 3"
- 740-1030 4"

Saw Set



Proper alignment of handsaws is a must. With the aid of a few tools, handsaws can be kept sharp. Once the saw teeth are filed sharp, the saw set is then used to reset the teeth. This tool sets blades up to 1.5mm thick. Made in Germany.

- 580-6400Saw Set 180mm Long

Python File Handles

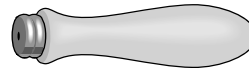

Python file handles are manufactured from the finest quality timber, and pressed inside the center of each handle is a steel spring, firmly secured and covered by a ferrule of special design. Together they take up all pressure when the file is driven in the handle. Use the file length indicated below as a guide only, as file tangs can vary. Made in England.

- | Number | Size | Fits File Length |
|----------|------|------------------|
| 610-1000 | #0 | 3" to 6" |
| 610-1100 | #1 | 6" to 10" |

Universal Handle



Designed to firmly grip the tang of files, rasps and awls, this handle measures 4" long and has a tightening-loosening flat knob at the base of the handle which engages wedge-shaped grippers at the other end.

- 825-3650 Universal Handle

Chainsaw File



A handy file for touching up dull chain saw blades. Take with you to the job site and save time by keeping the chain saw blade at its best. Made in Portugal.

- 820-6000Chainsaw File 4mm (5/32")
- 820-6020Chainsaw File 4.8mm (9/16")
- 820-6040Chainsaw File 5.5mm (7/32")

Horse Rasp

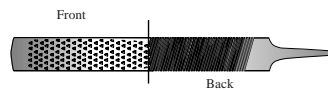

Sometimes referred to as a "Ferrier's Rasp". One side of the Horse Rasp has a rasp for coarser work and the opposite side has a file for smoother work. This 2 in 1 feature is very handy when working at the bench. Made in Portugal.

- 820-5500Horse Rasp

Cork Sanding Block

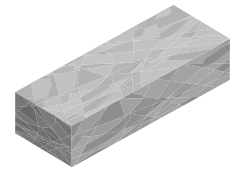

This sanding block is made of compressed cork with beveled edges. Inexpensive, and yet one of the most useful sanding blocks available. Can be carved to the shape of various mouldings with ease. Length of 4 5/8", width of 2 3/8", and thickness of 1 3/8".

- 560-5500Sanding Block

Sleeveless Sanding Drum Set

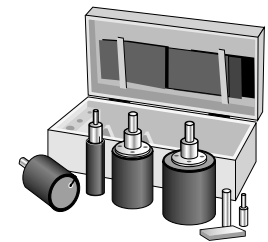

An economical set of sanding drums. Cut and fit sandpaper to the drum, lock it into place with the specially designed locking tube. Use in 1/2" motor arbors or in a drill press chuck. Drums are 3" in length and include diameters of 1", 2 1/8", 2 5/8", and 3 1/8". Also included are 1/4" and 1/2" shank adapters. Imported.

- 825-2150Sleeveless Sanding Drum Set

Contour Sanding Set

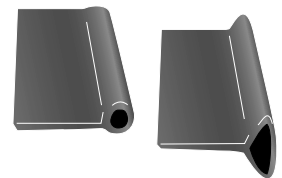
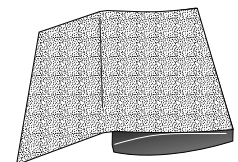

Ingenuous sanding aids made of flexible rubber ideal for sanding curved, round or grooved shaped surfaces. To use, simply wrap standard sanding paper around the different profiles. Set of eight includes three sanding pads and five profiles.

- 825-6575 Contour Sanding Set



RIFLER FILES & RIFLER RASPS

Hand Cut Riffler Rasps

These specialty rasps are made to an exceptional level of quality. Hand cut by a journeyman file and rasp maker, these rasps are made in the original way in a small workshop in Portugal. Sets in three sizes with the larger size tools being available individually. Fantastic quality!

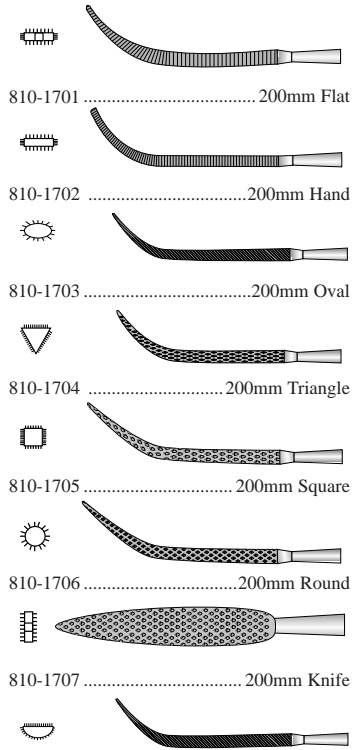

- 810-1701200mm Flat
- 810-1702200mm Hand
- 810-1703200mm Oval
- 810-1704200mm Triangle
- 810-1705200mm Square
- 810-1706200mm Round
- 810-1707200mm Knife
- 810-1708200mm Half Round
- 810-0460Set of Eight - 200mm

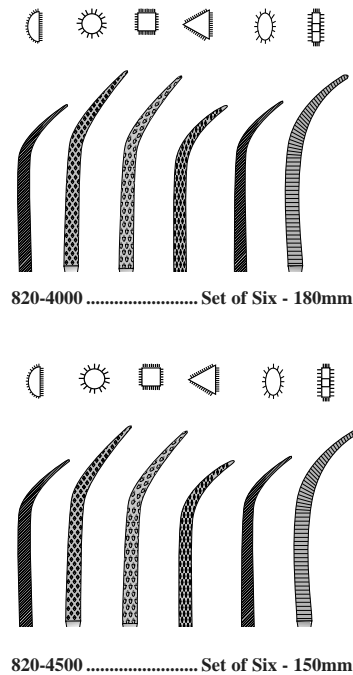

- 820-4000Set of Six - 180mm
- 820-4500Set of Six - 150mm

Riffler Rasp Sets



An economical set of riffler rasps for the beginner or occasional carver. Set of eight riffler rasps are made in China. 825-3600Riffler Rasp Sets

Needle File Set

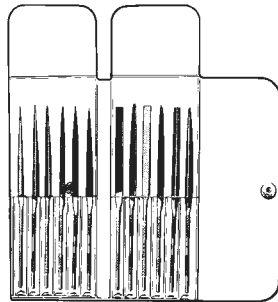

Needle file sets are in an assortment of twelve #0 cut needle files, in a plastic wallet. All files are 140mm in overall length and are machine cut. These files are made in Portugal. 810-0405Set of 12

Sander/Rasp

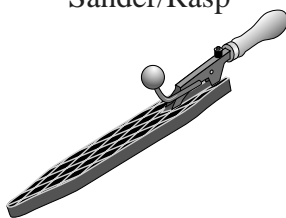

This unique shaping tool cuts like a rasp, but leaves a finish like that of a sanding tool. The adjustable style tool (illustrated) has a replaceable blade. Both tools feature fine and coarse teeth on opposite sides of the tool, and make quick work of any wood shaping and finishing job. Made in Japan. 745-0500Fixed Handle 11" x 1 1/16" blade
745-0000Adjustable Raised Handle
745-0001Blade Only for 745-0000

Riffler File-Rasps

Similar to the other riffler rasps found on this page, these quality rifflers are file-cut on one end, and rasp-cut on the other. Both sides of the tool have the same shape, so that you can rough shape with the rasp side, and immediately turn the tool around to finish with the file side. Hand cut in Portugal, these riffler and file combinations are 210mm in overall length.

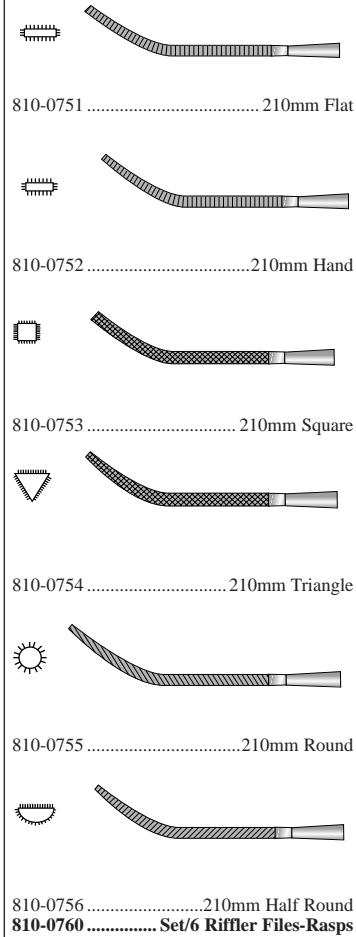

- 810-0751210mm Flat
- 810-0752210mm Hand
- 810-0753210mm Square
- 810-0754210mm Triangle
- 810-0755210mm Round
- 810-0756210mm Half Round
- 810-0760Set/6 Riffler Files-Rasps

Staircase Makers Rasp

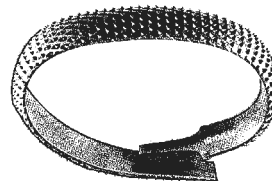

This tool was originally designed to assist the staircase-maker in his work, but has now found it's way into the woodcarvers tool box. Once you have this unique rasp, you will not know how you got along without it! Size is the approximate circumference. Made in Portugal. 820-5050150mm
820-5075250mm

Needle Rasp Set

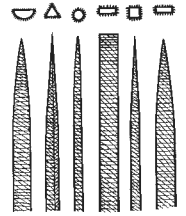

A set of six very useful needle rasps of assorted configurations. All are 140mm long and the set is packed in a plastic wallet. Made in Portugal, these high quality needle rasps are cut by hand. Overall length of 140mm

- 810-0440Needle Rasp Set

Handy Rasp Set

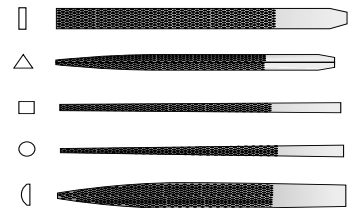

For heavier or larger work these square handled riffler rasps are just the tool. Slightly longer (215mm) than our other rifflers, these tools are made from heavier stock presenting a larger cutting surface. Hand cut, these rasps are made in Portugal.

- 820-2000Set of Five

Riffler Rasp

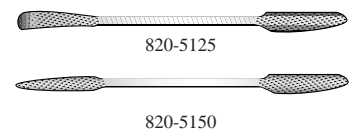

These two larger rifflers are hand cut and will prove extremely useful in carving and general woodworking applications. Overall length is ten inches, so these tools are larger than others found on this page. Hand cut in Portugal. 820-5125Half-Round
820-5150Oval

Large Riffler Rasp

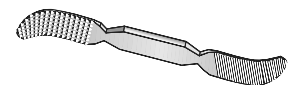

Similar to smaller riffler file-rasps, this single shape tool was originally designed for the staircase-maker. There are simply some jobs where size is important, and at 9 1/2" in length this tool will take care of those situations like nothing else will. Made in Portugal. 820-5025Stair Case Rasp



HIGH SPEED STEEL TURNING TOOLS

Robert Larson™ turning tools are manufactured to the highest quality. A wide variety of tools are available that will allow the best possible selection for the woodturner.

The Blades

The most important issue in a well designed turning tool is the quality of the blade. All Robert Larson™ blades are manufactured to precise specifications.

The steel is M2 molybdenum based high speed steel which is machined from the solid in most cases. A few tools are entirely forged into shape. Next the tool is heat treated, being hardened and tempered to sixty-two degrees on the Rockwell "C" scale.

By no means is this the end of the manufacturing process as the blades are next machine ground and, in a number of cases, hand ground as well. The cutting edge is carefully ground, with this being followed by hand glazing and polishing of the tool surface. Polishing is linear to the blade length, unlike other manufactur-

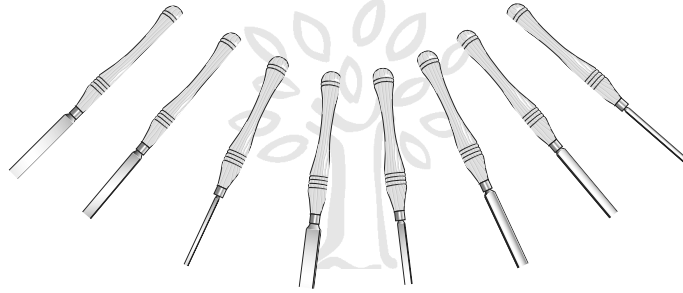

ers that leave circular polishing markings on the blade. In the case of fluted tools, polishing is accomplished with specially shaped abrasive impregnated rubber wheels.

A thorough quality inspection is made on each and every tool before it is proudly marked HSS Steel, Made in Sheffield England.

The Handles

While the blades may be the most

important part of a woodturning tool, the handle can make a tremendous difference in the accuracy of your turning, as well as how long you can turn before getting tired. Robert Larson™ turning tool handles were designed in consultation with a leading woodturning company (established over a century ago) to provide both a firm as well as comfortable grip that will let you do your best work for hours on end! The handle starts with a blank of quality ash wood which is shaped into a unique style with beaded

grips. While other manufacturers will apply a lacquer finish to the handle, our handles have an oil finish which provides a firmer grip. A solid brass sleeve is mounted on the front of the handle to strengthen the fitting of the blade tang into the handle. Each tool has been given the best size handle for the job.

Sets

A number of sets have been assembled to provide help in selecting the basic turning tools to begin your turning with. As you become more involved in turning simply add tools from the wide range available.

Specifications

Each tool is listed with a part number, overall handle length, blade length without handle, and the cutting edge size.



TURNING TOOL SETS

Set of Three Spindle Tools

Spindle tools are possibly the most commonly used and useful tools available to the woodturner. This set of three tools contains 1/4", 3/8", 1/2" full-size spindle tools.

920-0375Set/3 Spindle Tools

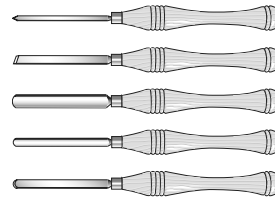
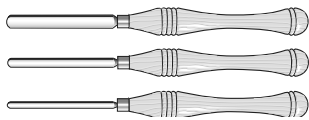

Set of Five

Great set for the beginning turner. Add more tools as your skill and needs grow. Includes 3/8" spindle gouge, 3/4" roughing out gouge, 1/2" skew chisels, 1/4" parting tool, and 1/2" round nose scraper.

920-0100Set/5 Turning Tools

Set of Three Micro Spindle Tools

Here is a set of three micro spindle tools. Set contains 1/8", 5/32", and 3/16" tools, all mounted on six inch handles.

920-0350Set/3 Micro Spindle Tools

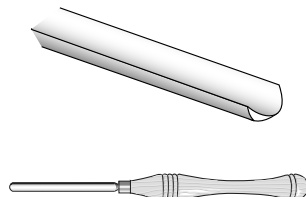

Set of Eight

This set will allow you to undertake a variety of scraping and cutting operations. Includes 1/4" and 1/2" spindle gouges, 3/4" roughing out gouge, 1/2" and 1" skew chisels, 1/4" parting tool, 3/4" round nose scraper, and 1" square nose scraper.

920-0150Set/8 Turning Tools

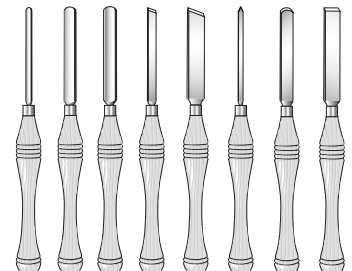

Set of Three Mid-Size Tools

Three of the most popular mid-sized tools. Great for those getting started with lathe turning. Includes the versatile 3/8" Bowl Gouge, the very useful 1/2" Oval Skew and the essential 1/8" Parting Tool. All have 6" handles.

920-0400Set/3 Mid-Size Tools

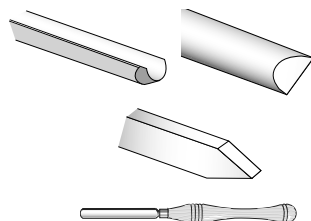

Miniature Set

If you enjoy doing smaller work, or take a great deal of time turning details on larger work, this will be an essential set of five tools. Includes 1/8" and 1/4" spindle gouges, 1/4" skew chisel, 2mm parting tool, and 1/4" round nose scraper.

920-0300Set/5 Miniature Tools



HIGH SPEED STEEL TURNING TOOLS

Spindle Gouge

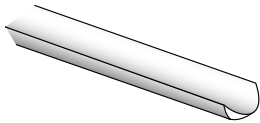

This well established, basic tool is used for a wide variety of work, including light roughing work and finishing between centers. A lighter and shorter tool than bowl gouges.

- 920-0530 10"200mm 1/4" (6mm)
- 920-0535 10"200mm 3/8" (10mm)
- 920-0540 10"200mm 1/2" (13mm)
- 920-0545 14"300mm 1/2" (13mm)
- 920-0550 10"200mm 3/4" (19mm)
- 920-0555 14"200mm 1" (25mm)

Bowl Gouge

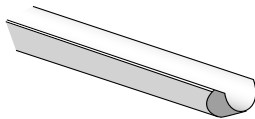

Indispensable, traditional tool with a round and thicker profile for making bowls. The 1/4" gouge is for more delicate work and the 1/2" and 3/4" gouges are for roughing out and general work.

- 920-1010 14"300mm 1/4" (6mm)
- 920-1015 14"300mm 3/8" (10mm)
- 920-1020 14"300mm 1/2" (13mm)
- 920-1025 16"300mm 3/4" (19mm)

Parting Tool

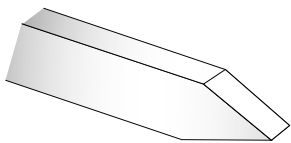

Traditional rectangular cross-sectioned tool used to part, or separate, workpieces done between centers.

- 920-4525 10"150mm 1/8" (3mm)
- 920-4530 10"200mm 1/4" (6mm)

Round Nose Scraper

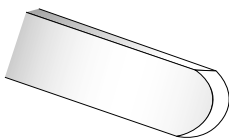

A very useful scraper for spindle and face turning work. Designed for concave shaped surfaces and general embellishments.

- 920-5015 10"200mm 1/2" (13mm)
- 920-5020 10"200mm 3/4" (19mm)
- 920-5025 10"200mm 1" (25mm)
- 920-5030 14"200mm 1 1/4" (32mm)

Roughing Out Gouge

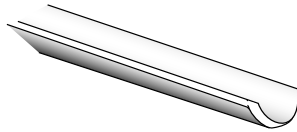

One of the basic and necessary turning tools for both beginners and advanced turners. Used to remove waste from spindle and faceplate turnings.

- 920-1510 10"150mm 1/2" (13mm)
- 920-1515 10"200mm 3/4" (19mm)
- 920-1520 14"200mm 1 1/4" (32mm)

Oval Skew

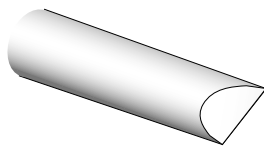

The oval skew offers smooth usage and won't cut into the tool rest. It is also quite nice for shaping beads and cylinders.

- 920-2010 10"200mm 1/2" (13mm)
- 920-2015 10"200mm 3/4" (19mm)
- 920-2020 14"200mm 1" (25mm)
- 920-2025 14"200mm 1 1/4" (32mm)

Diamond Side Cutting Scraper

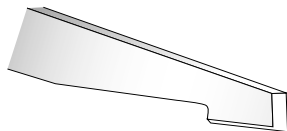

Designed to undercut when making square edges or corners at the bottom of boxes. The square shape allows for smoothing straight side walls.

- 920-6510 10"200mm 3/4" (19mm)

Bedan Tool

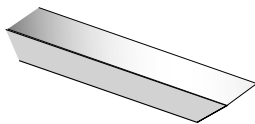

This parting tool quickly makes accurate and repetitive sizing cuts on spindles. It's outstanding when making bead cuts or smoothing small diameter spindles. The tool's sides slope inward to reduce potential binding.

- 920-7010 10"266mm 3/8" (10mm)

Skew Chisel

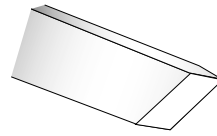

An essential turning tool: the skew chisel is used for paring and trimming surfaces. Also for shaping beads and other detail configurations.

- 920-2515 10"200mm 1/2" (13mm)
- 920-2520 10"200mm 3/4" (19mm)
- 920-2525 10"200mm 1" (25mm)
- 920-2530 14"200mm 1 1/4" (32mm)

Skew - Rounded Edge

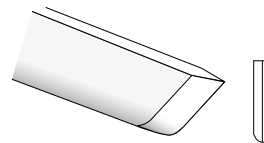

Instead of a flat bottom edge, this skew has a rounded surface which permits the tool to smoothly roll and slide on the tool rest. It offers superior performance when making rolling cuts as is done when beading.

- 920-3010 10"200mm 1/2" (13mm)
- 920-3015 10"200mm 3/4" (19mm)
- 920-3020 10"200mm 1" (25mm)
- 920-3025 14"200mm 1 1/4" (32mm)

Square Nose Scraper

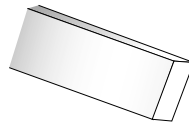

The square nose scraper is an essential tool used to improve the surface of flat bottoms in boxes or make straight cuts down the side of boxes or hollow cylinders. It is also excellent for outside faceplate work.

- 920-5510 10"200mm 1/2" (13mm)
- 920-5515 10"200mm 3/4" (19mm)
- 920-5520 10"200mm 1" (25mm)
- 920-5525 14"200mm 1 1/4" (32mm)

Round Nose Side Cutting Scraper

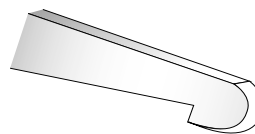

Designed to undercut when making vessel or bowl openings or lips. The round shape allows for radius undercuts and smoothing curved side walls.

- 920-6010 10"200mm 1/2" (13mm)
- 920-6015 10"200mm 3/4" (19mm)
- 920-6020 10"200mm 1" (25mm)

Beading & Parting Tool

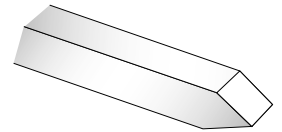

A 3/8" square chisel used for sizing, making beads or v-grooves on cylinders between centers.

- 920-7510 10"266mm 3/8" (10mm)

Combination Ring Tool

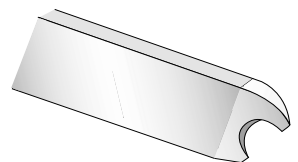

A specialized tool for making loose decorative rings which are captive to the neck of a vase or goblet.

- 920-8010 10"200mm 1/4" (6mm)
- 920-8015 10"200mm 3/8" (10mm)
- 920-8020 10"200mm 1/2" (13mm)

Diamond Parting Tool

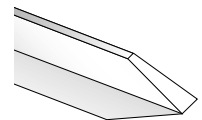

A first rate variation of the standard parting tool. The tool's cutting edge is 3/16" wide and tapers to less than 1/8" at the top and bottom thus reducing the cross sectional profile and reducing friction when parting.

- 920-4510 10"200mm 3/16" (5mm)

Fluted Parting Tool

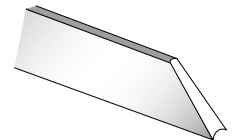

A uniquely designed parting tool featuring a radius groove at the cutting edge with two spur-like points to score the wood before the center radius makes the parting cut thus reducing or eliminating end-grain tearing. The tool's taper profile also reduces friction.

- 920-4515 10"200mm 3/16" (5mm)



HIGH SPEED STEEL TURNING TOOLS

Hollowing Tools

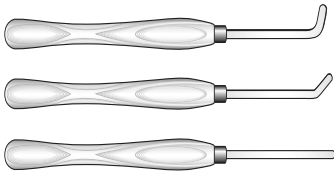

Three different shapes are offered for working within vessels or bowls. The two bent hollowing tools are designed for enclosed structure turning while the straight hollowing tool can be used for any turning where access is limited.

- 920-5310 6"125mm Straight
- 920-5320 6"125mm45° Bent
- 920-5330 6"125mm80° Bent

Ring Tools



A tool specially designed to hollow into end grain and leave a smooth cut. It is also a useful tool for bowls, goblets and other vessel shapes.

- 920-8210 10"200mm1/2"
- 920-8220 14"300mm 1"

Bowl Scraper

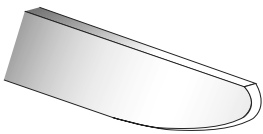

The gradient shape of the bowl scraper is ideal for shear scraping curved bowl walls. This unique cutting edge design reduces the tendency associated with straight edge tools of digging into curved surfaces.

- 920-8510 14"200mm1 1/2" (32mm)

Heavy Duty Scraper

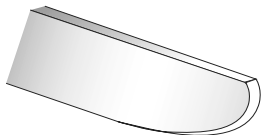

A larger and heavier version of the bowl scraper. The weight and size helps to reduce vibration and tool chatter when performing the final smooth finishing of a turning.

- 920-9010 16" 254mm ... 1 1/2" (38mm)

Round Skew Chisel

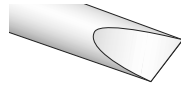

Designed to overcome the limitations of square skew tools, the round shape permits more maneuverability while sliding smoothly on the toolrest. The round shape is also very strong and tends to dampen vibrations while producing smooth wood surfaces. The skew shape, besides making smoothing cuts, is easily used to form beads. Available in three worthwhile sizes.

- 920-9510 10"150mm1/4" (6mm)
- 920-9515 10"175mm3/8" (10mm)
- 920-9520 10"200mm1/2" (13mm)

Shear Scrapers

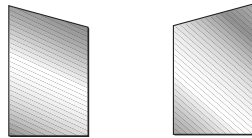

Left to Right Right to Left

The ideal tools for smoothing the rough surface left by gouges. These are thick and heavy and made to minimize vibrations while producing flawless surfaces, especially on the outer surfaces of bowls. Available for smoothing actions, Left to Right and Right to Left.

- 920-5610 10"200mm L-R-1"
- 920-5620 10"200mm R-L-1"

Box Scrapers

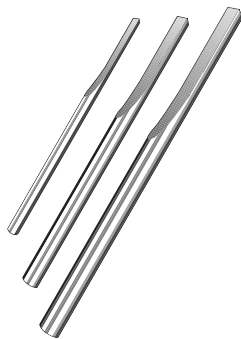

The box scraper is ideal for cleaning up rough end grain in open turnings, such as, goblets, boxes or other vessels. It is made from round stock, facilitating a smooth rolling action on the lathe rest and when making shear scraping types of cuts on end grain. Available in three sizes for different sized work.

- 920-5810 10" ..150mm 1/4"
- 920-5820 10" ..175mm 3/8"
- 920-5830 10" ..200mm 1/2"

Diamond Point Tool

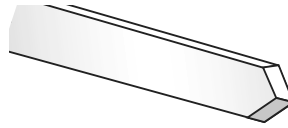

A favorite tool of experienced turners and one of the basic turning tools for beginners. Useful for a variety of applications, including fitting lids on boxes, truing tenons and recesses, making jam chucks and shear scraping on the outside of small pieces. Highly recommended.

- 920-6550 10"200mm 1/2"

Wedge Tools



Easy to use tool which leaves a smooth surface. It's used to create coves in spindle work but it is also useful as a scraping and cutting tool in both spindle and faceplate work. The cutting surface is flat thus reducing the tool's catching or digging into the turning surface.

- 920-7410 10"200mm3/8"
- 920-7420 10"200mm1/2"

Dovetail Tool

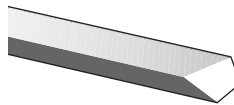

This tool is designed to quickly make a precision fit dovetail recess for chuck jaws.

- 920-6350 10" 200mm.....3/8"

Spiral Shell Auger Bit

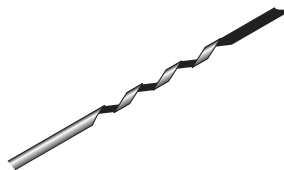

An improved design for boring long holes. The spiral shape facilitates the removal of waste material thus reducing the frequency of pulling it out of the hole for cleaning. Because the boring process is done by hand, a handle needs to be used, preferably one with sufficient length and diameter. The bit is 26" in overall length, and is fitted to a ten inch handle.

- 920-98063/8"

Miniature Tools

Small tools for small work or details on larger pieces. The blades without handles are an overall 125 mm in length, then mounted on our six inch handle.

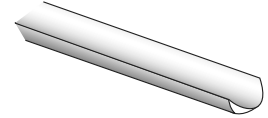

Spindle Gouge

- 920-0510 6"125mm 1/8" (3mm)
- 920-0515 6"125mm 5/32" (4mm)
- 920-0520 6"125mm 3/16" (5mm)
- 920-0525 6"125mm 1/4" (6mm)

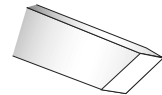

Skew Chisel

- 920-2510 6" 125mm.....1/4" (6mm)

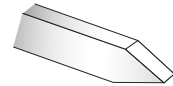

Parting Tool

- 920-4520 6" 125mm..... 2mm

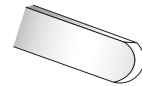

Round Nose

- 920-5010 6" 125mm..... 1/4" (6mm)

Mid-Size Tools

Three different mid-size tools. These turning tools are a little shorter than their full-size counterparts and can be extremely useful for smaller turnings, including pen turning. All three tools are fitted to a six inch handle.

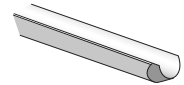

- 920-1050 Mid-Size Bowl Gouge 3/8"

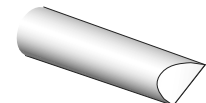

- 920-2050 Mid-Size Oval Skew 1/2"

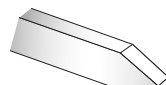

- 920-4550 Mid-Size Parting Tool 1/2"



TURNING - DIVIDERS & CALIPERS

Turner's Sizing Caliper

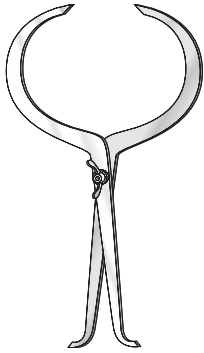

These high quality French turner's calipers make gauging the thickness of a turned bowl easy and fast. Simply close the caliper on the piece being gauged and measure the thickness on the other end of the caliper!

Maximum:	Inside	Outside
850-2222	110mm	170mm
850-2225	125mm	200mm
850-2230	150mm	250mm
850-2240	200mm	350mm
850-2250	500mm	450mm

Replacement Handles

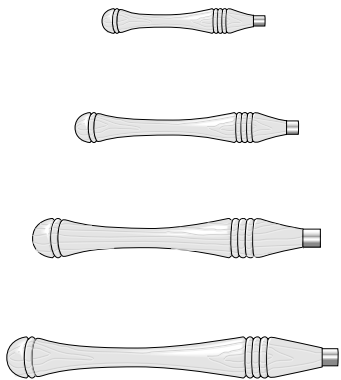

Same ash handle, with brass sleeve and oil finish, found on all Robert Larson™ woodturning tools.

926-80106"
926-802010"
926-803014"
926-804016"

Brass Sleeves

Solid brass sleeves or ferrules for making your own turning tool handles. Tumble polished. All measurements are in inches.

926-90100.5625 od 0.500 id 0.4375 long
926-90200.750 od 0.6875 id 0.6875 long
926-90301.00 od.09375 id 0.875 long
926-90401.125 od 1.00 id 0.875 long

Compasses, Dividers and Calipers

These French made tools are all superb quality and will make measuring and layout work easier and more accurate. All tools are nicely polished with brass fittings where feasible. In addition, all feature a unique quick-nut adjustment that is easy and fast to use. This is a broad assortment of styles and sizes, with all being hand finished and tested as the last step in the production process. Size indicates the maximum capacity.

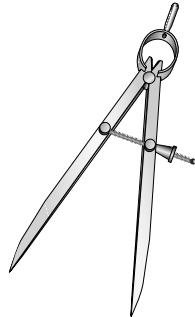

Dividers

850-1010100 mm
850-1015150 mm
850-1020200 mm

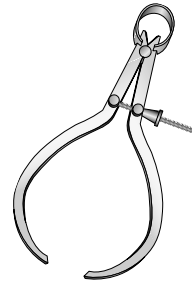

Outside Calipers

850-1210100 mm
850-1215150 mm
850-1220200 mm
850-1225250 mm

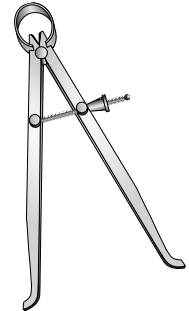

Inside Calipers

850-1100100 mm
850-1115150 mm
850-1120200 mm

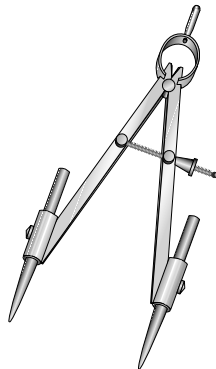

Compass with Carbide Points—B

850-2110100 mm
850-2115150 mm
850-2120200 mm

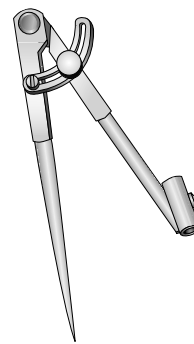

Compass with Quadrant—C

850-2316160 mm
850-2319190 mm
850-2322220 mm
850-2325250 mm
850-2331310 mm
850-2340400 mm

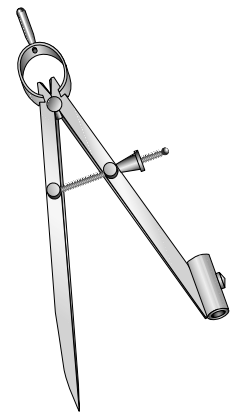

Compass—A

850-1310100 mm
850-1315150 mm
850-1320200 mm

Turner's Sanding Pack

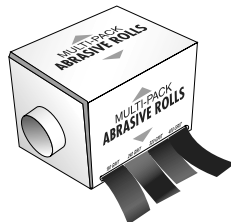

This dispenser contains four one inch by twenty foot rolls of cloth backed aluminum oxide abrasive. Contains rolls of 150, 220, 320, and 400 grit abrasive. The convenient design allows you to quickly obtain the length of abrasive you need.

825-2200 Turner's Sanding Pack

Moisture Meter

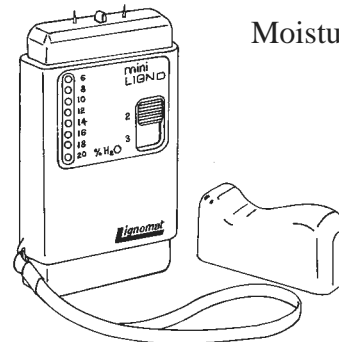

Comes with two sets of probes that allow the meter to measure moisture content at depths of 3/16" and 7/16". As probes are pressed into the wood, an on-off switch between the pins turns the meter on automatically. The moisture content is indicated in percent by a red LED light. In case of interim values, two LED's light up at the same time. Powered by one nine volt battery. Meter will read from 6% to 20% moisture range.

Lignomat

180-0000 Moisture Meter
180-1350 Short 3/16" Pins Only - Pair
180-1400 Long 7/16" Pins Only - Pair



MEASURING & LAYOUT TOOLS

Center Finder

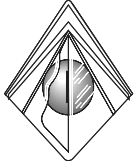

Finds exact center in seconds with no calculations. Gives center of round, square, hexagon and octagon stock for turning in a lathe or other purposes. Maximum 8" circle and octagon; 8" square; 5 3/4" hexagon.

800-2875 Center Finder

Bevel Gauge

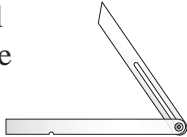

This all-metal bevel gauge is slim, sturdy and easy to use. A small notch is provided for releasing the blade from its storage slot. The blade is then locked at the desired location via a knurled knob. Available in two lengths and both easily fit in apron or pants pockets. Shinwa.

730-4500 Bevel Gauge 150mm (6")
730-4550 Bevel Gauge 250mm (10")

Transfer Bevel

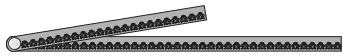

This nicely finished stainless steel bevel has a strong friction joint that allows easy setting yet holding strength to prevent movement. Blades are 19/32" wide and 3/64" thick. Leg lengths of about seven and eleven inches. Shinwa.

730-4000 Transfer Bevel

Brass Caliper

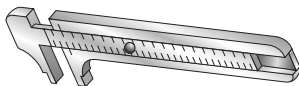

Solid brass caliper will quickly determine the thickness of material. Perfect tool to keep in your pocket or in your shop apron.

885-2050 Caliper

Thickness Gauge



Use for quick measuring of stock from 1/32" to 2" in 1/32" increments. Great for measuring the wall thickness of bowl and other turnings.

825-5100 Thickness Gauge

Combination Square Set

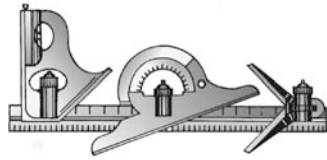

This combination set is great for the woodworker and includes a mitre square head, center head, and protractor head -- all on a 12" stainless steel blade marked in both inch and metric measurements. The square head has a built-in spirit level that is viewable from the top, bottom, and sides. A small scribe is also located in the square head. This scribe screws into the storage spot, so there is less chance of it being lost. The protractor head allows any angle between 0° and 180° to be worked. The centering head makes it easy to find the center of round work, making it ideal for turners. All heads are removable and adjustable.

630-4200 Combination S square Set

Combination Square

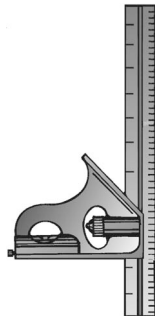

Heavy duty combination square. A cast iron stock distinguishes this square from others. Faces are ground for accuracy, and the head incorporates a high visibility vial, scribe, and brass adjusting screw. Blade is 12" long overall.

630-5000 Combination Square

Small Combination Square

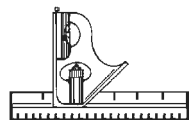

This finely made combination square can be just the tool for certain layout work. The blade is 6" long and made of aluminum. Unlike some smaller combination squares, the stock and blade of this quality tool are made to work together.

630-4110 6" Combination Square

Mitre Square

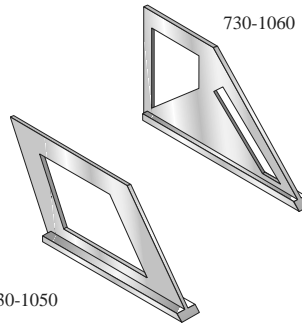

Finely made tools which are extremely useful for layout and machine setup. The mitre square checks 45 or 135 degree angles. The Combination square adds ninety degree capability and useful markings.

730-1050 Mitre Only
730-1060 Combination Square

Wrap-Around Mitre Square

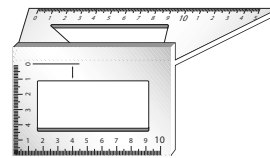

A clever layout tool comprised of two right angle elements attached to one another. One element shape is rectangular with a rectangular opening. The other element has 45° and a 90° shaped edges with a similar cut out. In this configuration, the mitre square is unique for doing layout work on two surfaces on a board. The outer edges have millimeter calibrations. The Wrap-Around Mitre Square is ideal for laying out mortise and tenons, picture frame corners, chair legs and a myriad of other applications. Shinwa.

730-1070 Wrap-Around Mitre Square

Angle Divider

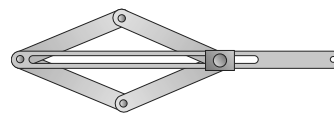

This tool makes it easy to divide an angle in half for accurate mitering as well as transferring angles from 10° to 170°. Makes finish carpentry significantly easier and faster. Commonly used angles are marked for ready reference.

800-2000 Angle Divider

Folding Rules



Folding rule, made from well seasoned hardwood with brass joints. Accurately machined with large markings. This is the same measuring device that has been used by generations of woodworkers and craftsmen. European made.

650-1167 Three Foot Folding Rule

Steel Rules

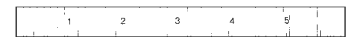

Rustless stainless steel ensures that these rules retain their finish. Permanent etched graduations show metric graduations of 0.5 mm, mm, cm. Imperial graduations of 1/16", 1/32", 1/64".

900-1040 6" w/Hanging Hole
900-1060 12" w/Hanging Hole
900-1080 24" w/Hanging Hole

Engineer Square

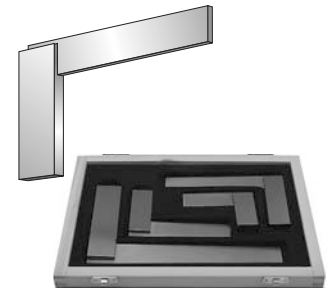

Engineer's try squares are workshop grade with hardened blade. Both blade and stock are ground for straightness and accuracy. All sizes are extremely useful for machine setup, and the smaller sizes can be helpful when working on miniature projects. Set contains squares 2" through 6" in a wooden box.

885-1002 2" | 885-1006 6"
885-1003 3" | 885-1009 9"
885-1004 4" | 885-1012 12"
885-1500 Set in Wooden Box

Trammel Heads

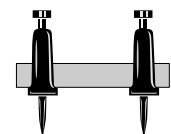

One pair of heads, when mounted on a beam 1/2" to 1 1/8" wide, provides an efficient and convenient means of laying out points, arcs, and circles. Can hold a pencil as well. Kunz

580-4100 Trammel Heads



MEASURING & LAYOUT TOOLS

Contour Gauge

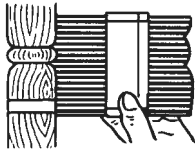

Quickly copies and holds irregular shapes when the steel teeth are pressed against the work. The outline can then be transferred by marking along teeth. Extremely helpful in cutting floor coverings to fit, coping work, and other jobs where work is cut to fit. Two six inch gauges can be joined together. Made in Japan.

- 799-10006" Contour Gauge
- 799-200012" Contour Gauge

Contour Gauge

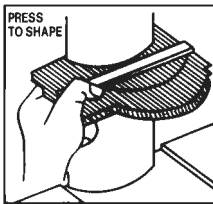

Professional contour gauge with plastic pins is ideal for joinery work, fitting tiles, carpets, linoleum, etc. Two gauges can be combined for a longer length if necessary.

- 800-2510 5"
- 800-2520 10"

Hooked Rules



Steel rules in two lengths. Both are marked in both metric and inches. The hook easily grabs the end of a board or it can be adjusted so that one side is hook-free and the other remains as a hook. The hook assembly can also be removed for standard scale type uses.

- 825-517512" Hooked Rule
- 825-520018" Hooked Rule

Self-Adhesive Rule

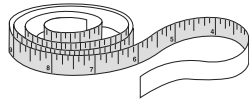

Save time and effort by not hunting for a bulky tape pocket measure by attaching this self-sticking 48" rule to workbenches or other work surfaces. Available for Left-to-Right or Right-to-Left applications.

- 825-610048" Left To Right
- 825-612548" Right To Left

Wheel & Circle Cutter

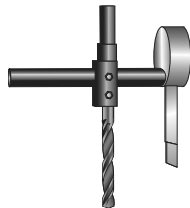

This wheel (disc) and circle cutter is designed to give clean cut edges for both the hole and the cutout wheel. This is accomplished because the HSS cutter has two cutting edges. It also has a 1/4" pilot drill bit and is adjustable to cut wheels from 1" to 6" in diameter. Designed for use in a drill press at speeds no greater than 500 rpm. Used properly, it can also cut plastics and soft metals, such as copper or aluminum.

- 825-6510 Wheel & Circle Cutter

Flexible Curve Rule



Laying out and marking an irregular line can throw any woodworker a "curve", but with this useful tool the job can be done simply and with accuracy. A lead core is surrounded by a vinyl body that includes a raised "inking" edge. This rule is twenty-four inches long, is infinitely adjustable, and will lay flat on your drawing board or workpiece.

- 730-3060Curve Rule

Bevel Scale



Tired of frustrating attempts at setting bevel gauge (T-bevel) angles to an exact angle? This very handy device makes it effortless to set angles. Simply place the Bevel Scale next to the bevel gauge and adjust to the well-marked angle of choice. Marked in quarter degrees from 0 to 50° it is 3" x 12". The reverse side features a centering scale in centimeters and a left reading-right reading scale. One end of the scale has a vertical height scale, ideal for height adjustments on table saw blades or router cutters. All markings are chemically etched and highly accurate. T-Bevel not included.

- 825-5300Bevel Scale

Mite-R-Gage

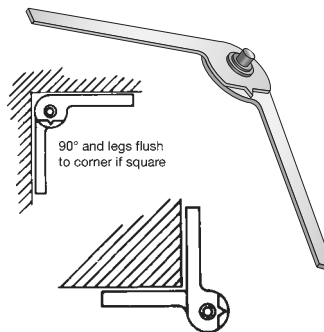

Take the guess work out of angles. Fully rotational through 360° the Mite-R-Gage uses two legs that allows you to measure both inside and outside angles, transfer exact angles direct to stock, check corners for squareness or set alignment of arm or table saw. It can layout simple or compound miters. Overall length of each leg is 11 1/2". USA.

- 238-1000Mite-R-Gage

Protractor

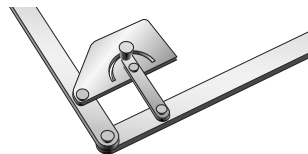

A multipurpose addition to your lay out tools. The built in protractor makes for accurate measuring and transferring of all angles. Also indispensable as a ruler and marking & cutting guide. This aluminum tool features extra length 20" and 9" arms, easy-to-read markings, and brass tightening screws.

- 800-2010 20" long

True Angle

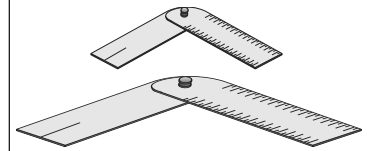

The True Angle™ is a superior measuring and layout tool that makes angles faster! Make and measure inside and outside corners with great accuracy. Available in four sizes to accommodate every variety of work. USA.

- 148-1106 Pocket Size
- 148-1112 Folder Size
- 148-1118 Desk Size
- 148-1123 Shop Size

Attachable Dial

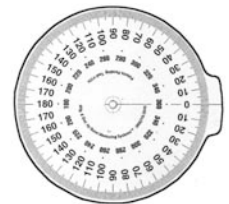

This is the perfect accessory for the True Angle marker. This four inch dial is quickly attached to any True Angle so that you can more easily read degrees directly and instantly. USA.

- 148-1104Attachable Dial - 4"

Crown Molding Book



Install crown molding and trim like a Pro! Easy to follow three step method is written for the novice do-it-yourselfer. Over 350 photographs with easy to understand instructions. Includes many tables and charts for faster work. Kit contains the book along with pocket and desk size True Angle tools.

- 148-2000Crown Molding & Trim (Book)
- 148-2025 Kit with Book and Tools



MEASURING & LAYOUT

Marking Gauge

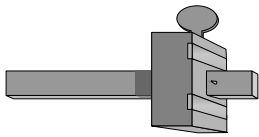

Essential for marking parallel lines to an edge with the grain. Made from the best quality beech, this marking gauge features a square head with inset brass wear plates, and locks with a thumbscrew so that no screwdriver is needed. Overall size is approximately 9", and tool is made in England.

605-1050 Beechwood Marking Gauge

Cutting Gauge

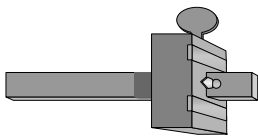

Made from the best quality beech, this cutting gauge features a square head with inset brass wear plates, and locks with a thumbscrew so that no screwdriver is needed. The tool is used for scoring across the grain, and it can also be used for cutting strips of wood veneer and small rebates. The cutter is securely held in place by a brass wedge, which enables the cutter to be removed for sharpening. Overall size is approximately 9", and tool is made in England.

605-1100Beechwood Cutting Gauge

Mitre Squares

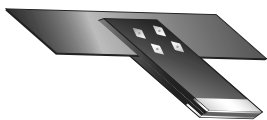

Accurate marking of mitre joints at 45° and 135° angles. Same high quality as our rosewood try squares using the best quality rosewood and tempered steel blades. Blade is securely held by steel rivets with surrounding inlaid brass diamonds. Made in England.

605-2300Rosewood 10" Mitre Square



Miniature version for model making, or other small work. Round rivets hold the blade in place. Made in England.

605-4050 4 1/2"

Mortise Gauges

A selection of mortise gauges, all of the highest quality and made for discriminating craftsmen by craftsmen in Sheffield, England.

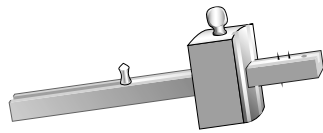

Highest quality beechwood has brass wear strips on the rubbing face. One side is for marking mortises and has a sliding adjustment mechanism. The other side has a single pin which allows the tools to be used as a traditional marking gauge. Thumbscrew locking mechanism. Overall approximately 7 3/4"

605-1250Beechwood Gauge

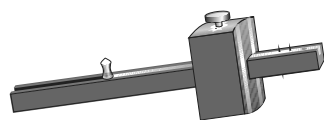

Similar to the beechwood mortise gauge above, but made from the finest rosewood available. Also features a knurled brass thumbscrew for locking the gauge in place. Overall size is approximately 7 3/4"

605-1150Rosewood Gauge

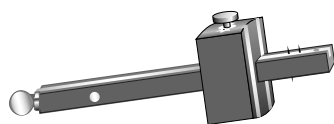

Here is an exquisite tool that is easy to adjust and wonderful to use. Brass wear strips on the rubbing face, an extra pin for use as a marking gauge, and a brass knurled thumbscrew are all here. In addition, this tool features an inlaid brass head shield and a screw adjustment of the second pin for precise adjustment. This is truly a fine tool that will last a lifetime! Overall size is approximately 8"

605-1200Screw-type Rosewood Gauge

Small Levels



These fine tools are based upon a traditional design having a full upper brass plate and lower brass tipped ends. The body of the level is made of the best quality rosewood. Made in England.

605-3506 6" Level
605-3512 9" Level

Rosewood Try Square

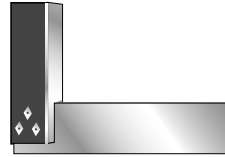

Made from the best quality rosewood and tempered steel blades, these squares have a brass face for protection against damage and wear. The blade is securely held by steel rivets with surrounding inlaid brass diamonds. Made in England.

605-2250Rosewood 6" Try Square
605-2260Rosewood 9" Try Square
605-2270Rosewood 12" Try Square

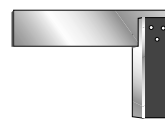

Miniature version try square is great for model work, or anywhere that a small square is needed. Round rivets hold the blade in place. Made in England.

605-40103"

Rosewood Marking Knife

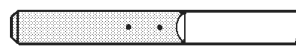

Made with a carbon steel blade and rosewood handle, this often overlooked little item is essential for accurate marking out. Overall length is 6 1/2" with the blade measuring 3/4" by 2 1/4". Made in England.

605-5000 Rosewood Marking Knife

Awl

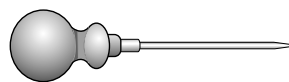

With a round ball handle that perfectly fits in the hand, and a long five inch tapered blade, this awl is extraordinarily useful for a wide variety of marking purposes. Made in England.

620-1200 5" Blade..... 7 1/4" OA

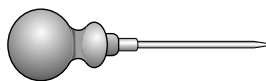

Similar to the awl above, but with a 2 1/2" blade and a bubinga wood handle. Made in England.

620-1250 2 1/2" Blade

Sliding T-Bevels

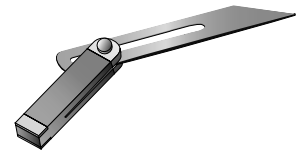

Adjustable to any angle, use this fine tool for marking or checking angles. The stock is made of rosewood with brass fittings, while the tempered steel blade is secured by a brass locking knob. Made in England.

605-3150 7 1/2"
605-3160 9"
605-3170 10 1/2"

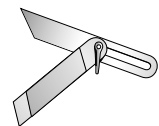

Miniature sliding bevel for model making, or other small size work. This tool locks with a turnscrew. Made in England.

605-4060 4 1/2"

Sliding T-Bevel

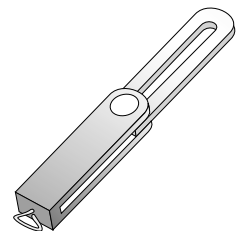

Sliding bevels are a must for every shop, and Shinwa bevels are finely made entirely of metal. Secure locking is achieved by means of an end tightening mechanism. Made in Japan

730-3008 8"
730-3010 10"

Dovetail Markers

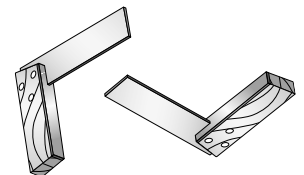

Two high quality tools made from the finest rosewood, brass, and tempered steel. One tool has a 1:6 ratio while the other 1:8. These are the most useful and traditional angles for handcut dovetails. Made in England.

605-4020 Set of Two Dovetail Squares



RICHARD KELL TOOLS - VERITAS TOOLS

Angle Master



Never again worry about machine tool setup when preparing multisided pieces. These precisely made gauges give you the exact angle needed for seven of the most commonly used angles. Constructed of durable plastic for long life. Made in England by Richard Kell.

625-4000 Angle Master

Conventional & Skew Honing Guide



The correct working face is used as the datum. Accurate hardened steel dowels provide the 90° datum for plane irons and chisels. A spring loaded pin provides location for Lie Nielsen skew blades, otherwise any skew can be held by using a slip of hardwood against the appropriate steel dowel. Clamping is by a wooden wedge, pattern provided. Full and comprehensive leaflet included. Exceptional quality in solid brass and stainless steel.

625-5700 0 to 2 1/2" capacity

Brass Caliper

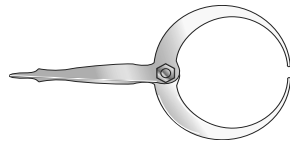

This beautiful double-ended caliper is 5" in overall length and has a high quality center point featuring very close tolerance parts. By rotating the two elements it can precisely measure either internal or external thicknesses. It is ideal for measuring wood thickness, such as the walls of turned bowls. Made in England by Richard Kell.

625-1000 Double Ended Brass Caliper

Drill and Dowel Gauge

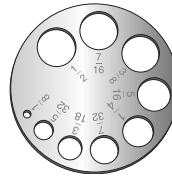

Made of solid brass, this tool should be accurate enough for anyone. (Tip: place over plugs before cutting off with a veneer saw, then chisel remainder.) Accurate to +/- .001" and made in England by Richard Kell.

625-4500 Drill & Dowel Gauge

Bevel Gauge



Indispensable quick check for grinding and honing. Has the twelve most common angles between 15° and 120°. Comes with hole for key chain so you can keep it handy. Made in England, of solid brass, by Richard Kell.

625-3000 Bevel Gauge

Center Finder

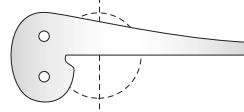

This tool makes finding the center of 3/4" to 8 1/2" stock a pleasure as well as a breeze. Made in England, of solid brass, by Richard Kell.

625- 2500 Center Finder

Adjustable Bevel

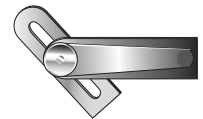

The sliding section of the adjustable bevel is 2 3/4" long and the base is 3 1/2" and 1/8" thick. Featuring a knurled lock and high quality construction, this handsome T-bevel is sized for convenience and a wide range of shop applications. Made in England by Richard Kell.

625-0500 4" Adjustable Bevel

Try/Setup Gauge

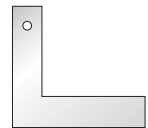

This solid brass tool lets you have a 90 degree angle available at all times (hole is for key chain). Overall tool size is 2 3/8" x 1 7/8". Richard Kell.

625-3500 Try/Setup Gauge

Brass Dovetail Marker



Double ended marker has 1:5 slope on one end for softwoods and 1:8 for hardwoods on the other. Deluxe model (illustrated) with right angle slot means there is no need to switch back & forth to a try square. Solid brass. Richard Kell.

625-2000 Standard Model
625-2050 Deluxe Model



VERITAS SAWS

DOVETAIL AND CROSSCUT SAWS

All three of these saws (top three tools in the photo to the right) are 14-1/4" long overall with blades that are 9-1/4" long and 0.020" Thick, with a cut depth of 1-9/16".

Choose from either the 14 or 20 rip-cut teeth per inch. The blades have only 0.003" Of set per side, with a 14° rake angle and included 60° angle. The 14 tpi model is most efficient on stock thicker than 1/2", while the 20 tpi version is best for stock under 1/2" thick.

The crosscut saw has 16 tpi filed with alternating bevels, again 0.003" Of set per side, and 15° rake and bevel angles. This is the saw to use for cutting across or perpendicular to the grain.

860-6200Dovetail saw 14 tpi
860-6250Dovetail saw 20tpi
860-6300 Crosscut saw 16tpi



CARCASS SAWS



These carcass saws (bottom two tools in the photo to the left) have a larger depth of cut than the dovetail and crosscut saws. Each saw is 16-3/8" long overall and weighs just under a pound. The high-carbon steel blade is 11" long and 0.02" Thick. The depth of cut is about 2-3/8". 12 Tpi rip saw has 10° rake angle and included 60° angle and 14 tpi crosscut saw has 15° rake angle, included 60° angle and teeth filed with alternating 15° bevels teeth have 0.003" Of set per side.
860-6350 Crosscut carcass saw 14tpi
860-6400 Rip carcass saw 12tpi

GENT'S SAWS



The gent's saws have a 7-7/8" long high-carbon steel blade that is 0.015" Thick with 0.003" Of teeth set per side. Available in both a 20 tpi rip saw tooth, or a 22 tpi crosscut saw configuration. Both saws have 1-5/8" cut depth.
860-6450 Rip gent's saw 20 tpi
860-6500Crosscut gent's saw 22 tpi



VERITAS TOOLS

Mk.II Honing Guide



860-8510 860-8520

Designed to make honing a chisel or plane iron fast with great accuracy. The blade registration system assures that the blade is square and the bevel is correct quickly and accurately. The clamping mechanism registers on the face of the blade, and is designed to accept flat and tapered blades. A three-position eccentric roller allows a microbevel to be honed easily. The tool will easily handle chisels 1/4" and blades as wide as 27/8" and 1/2" thick. The skew registration accessory allows you to quickly set both skew and bevel angles of chisel and plane blades, while the camber roller assembly facilitates putting a slight curve on the edge of a plane iron – desirable when using a smooth plane on large surfaces.

- 860-8500Mk.II Honing Guide
- 860-8510Skew Registration Jig
- 860-8520Camber Roller Assembly

Honing Compound



Made from a blend of abrasives that will quickly hone steel tools (both carbon and high-speed) to a mirror finish. For use on leather wheels, leather strops and shaped wooden forms.

- 860-6550 6.5 oz Honing Compound

Polished Burnisher



The traditional burnisher has been refined and perfected by Veritas. Given a new shape, this tool can take the place of separate oval, round, and triangular tools. In addition, the properly hardened steel is highly polished to make the job of burnishing a hook on your scraper even easier and more accurate.

- 860-2180 Burnisher

Grinder Accessories

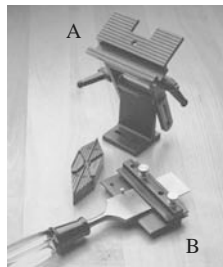

This tool mounts directly to the bench in front of your 6" or 8" bench grinder (it can be readily folded out of the way). It's 4" wide table straddles up to 1" wide wheels. Perfectly suited to the Veritas grinding jig and skew grinding jig.

- 860-2095A..... Grinder Tool Rest
- 860-2085B..... Grinding Jig

Clamp the tool to be sharpened in the jig adjusting the amount of blade projection you need for the bevel angle you want. Index lines ensure perfect alignment. Design will work with virtually all hand or power grinders.

Honing Guide & Angle Jig



The Veritas Honing Guide has a very wide roller, and is uniquely suited to adding a micro bevel after sharpening. Simply hone then turn the guide setting knob and give it a few more strokes. Especially useful when used with the angle jig which has the five most common bevel angles built into a pentagon wheel.

- 860-3010 Honing Guide
- 860-3020 Angle Jig
- 860-3021 ..Set / Honing Guide & Angle Jig

Variable Burnisher



Set the hook angle you want and burnish a clamped scraper. A precision-ground tungsten carbide rod in the brass angle-setting knob is held at exactly the right angle as you burnish. The ergonomic, injection-molded body keeps hands safely clear of sharp edges, and allows you to apply as much pressure as you wish. Nylon body with brass fittings.

- 860-2175 Variable Burnisher

Surface Clamp



Fast-acting surface clamp can be used anywhere you can drill a 3/4" hole. Can be used in material as thin as 5/8" so that it is ideal for use in jigs and fixtures. Precision machined from brass, steel, and anodized aluminum.

- 860-8600 Surface Clamp

Cornering Tool Kit



Two cornering tools giving you cuts with a radius of 1/16", 1/8", 3/16", and 1/4". Easy to use, they cut on either the push or pull stroke. Kit includes both tools and a sharpening block used with 600x silicon-carbide paper to keep the tools in great cutting condition.

- 860-2030 Veritas Cornering Tool Kit

Scraper Burnisher



This tool turns scrapers into cutters. Turners who are used to using scrapers with a grinder produced burr will be amazed at the difference a smooth edge-hook can make. After grinding the scraper you simply deburr the flat face and roll a hook on the edge. The pressure that you use determines the size of the hook. Designed for use with either full size, miniature, high speed, or carbon steel tools.

- 860-2250 Scraper Burnisher

Veritas Wonder Dog

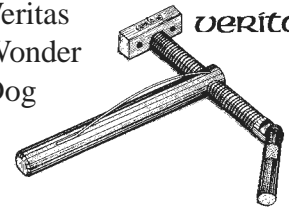

With a standard 3/4" diameter shank, these 6" long dogs can be used anywhere you can drill a 3/4" hole. Allows for a multitude of uses including long bar clamps, jigs, fixtures, and bench fittings.

- 860-2055 Wonder Dog

Bench Hold Down



Clamp your work to your bench or anywhere else that a 3/4" hole can be drilled. Clamping capacity is 8" and throat capacity 8" as well.

- 860-8200 Hold Down

Bench Dogs

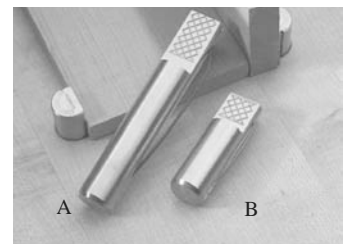

Smoothly ground dogs of excellent quality. Round in shape, style A is 4 3/8" long and 3/4" in diameter. Style B "Pups" are 2 1/2" long and are great for benches with tops up to 1 1/2" thick. They are also the perfect thing for use in bench sides; just drill holes in the skirt or edge of the top.

- 860-2070 Round (A)
- 860-2050 "Pup" (B)

Scraper Holder



Holds a scraper of 6"/150mm of any thickness. Simply clamp the scraper in position and set the amount of bow with the screw-actuated center pad. Made to fit your hands comfortably. Veritas

- 860-2200 Holder



VERITAS TOOLS

Power Tenon Cutter

veritas®



Designed for cutting tenons with shoulders in round workpieces. Available in eight cutting diameters, the smaller diameter cutters are ideal for building rustic furniture and the larger diameter cutters can be used for bed frames or fence rail to posts. Made of anodized aluminum and balanced for vibration-free usage. The cutters also have an integral bubble level for making more accurate cuts and they have a built-in honing guide for sharpening the blades on a drill press mounted drum sander. The Tenon Cutters are to be used with a hand held electric drill or a hand brace. Sizes 5/8" to 1" cut 2 3/4" long tenons and require a 3/8" or larger drill chuck. Sizes 1 1/4" to 2" cut 4 1/4" long tenons and require more torque to drive. They are for use in larger electric drills with a 1/2" or larger chuck.

- 860-5210 5/8"
- 860-5212 3/4"
- 860-5214 7/8"
- 860-5216 1"
- 860-5220 1 1/4"
- 860-5224 1 1/2"
- 860-5228 1 3/4"
- 860-5232 2"
- 860-5250 Replacement Blade Only

Mini Tenon Cutter



Designed for cutting tenons in smaller diameter workpieces, such as, chair rungs or trellis and lattice work. Available in six cutting diameters from 1/4" to 9/16". All sizes have straight blades which cut a 60° shoulder tenon. The 1/4", 5/16" and 3/8" sizes cut tenons up to 1" long and the 7/16", 1/2" and 9/16" sizes cut tenons up to 1 3/8" long. All sizes have a 3/8" shank diameter.

- 860-5404 1/4"
- 860-5406 3/8"
- 860-5408 1/2"
- 860-5409 9/16"
- 860-5410 5/16"
- 860-5414 7/16"
- 860-5450 Replacement Blade Only

"Snug-Plugs"

veritas®



These plug cutters cut a slightly tapered plug so that you can always get a good fit between the plug and the hole. Sides of the plugs will be smoother, due to the shaving cut that these cutters produce. Lastly, plugs will have a chamfered end for easy insertion! (Veritas)

- 860-3104* 1/4"
- 860-3105 5/16"
- 860-3106* 3/8"
- 860-3107 7/16"
- 860-3108* 1/2"
- 860-3100 Set/3 Inch marked * above

Transfer Scribe

veritas®



Used for transferring the contours of one shape onto another, this scribe simplifies any number of jobs. Fully adjustable from 0" to 12". Includes a bidirectional compass and an extra-hard indelible pencil.

- 860-1300 Transfer Scribe

Indelible Pencils



These pencils will leave a mark or line longer than others - and require very little pressure in use.

- 860-4040 Package of Ten Pencils

Square Fence



A clever and handy accessory for the standard carpenter's square. By attaching the fence to a square it quickly and accurately aligns the square to the workpiece edge. Secured by two brass screws, the 8" anodized aluminum extrusion fence can also be used as a handle. Works on straight and round-edge materials.

- 860-5510 Square Fence

Saddle Square



Nifty square for transferring a layout line from one perpendicular surface to another. Allows the easy location of one surface line on to the corresponding perpendicular surface.

- 860-5520 Saddle Square

Wheel Marking Gauge

veritas®



This marking gauge features a cutting wheel that solves many problems commonly associated with marking gauges. The sharp wheel cuts the grain of the wood cleanly, and the cutting edge is beveled in such a way that it forces the gauge face against the stock.

- 860-1400 Wheel Marking Gauge
- 860-1405 Spare Blade Only

Dovetail Markers



Handy aluminum markers can be flipped to mark both slopes of a dovetail. Color coded for convenience.

- 860-1045 Set of two

Center Finder



Set square or cylinder work (up to 6" across) in the marker, tap it with a mallet, turn the wood ninety degrees and tap it again. The knife-edged blade scores the dead-center of the wood.

- 860-1200 Center Marker

Saw Setting Gauge



The beauty of this gauge is that it is a full 3/4" thick ensuring that teeth are being gauged at the top of the arc, and it can stand on its own. Will set precisely any height or width from 1/8" to 2" in 1/8" increments.

- 860-6010 Saw Setting Gauge

Straightedges



A straightedge can prove of great benefit in setting up machines such as planers and jointers, but you will find them useful for layout work as well. The twenty-four inch steel tool is ideal for machine set-up. It is 1 1/2" wide by 1/4" thick. Both edges are ground flat to within 0.001" over the length of the tool. The thirty-eight inch aluminum straightedge is 1 1/4" wide and 7/16" thick. The reference edge is machined flat to within 0.003" over the length. Both tools have hanging holes for easy storage.

- 860-9050 24" Steel
- 860-9200 38" Aluminum

Dado Shims



Slotted and color coded dado shims make adjusting your dado set a breeze. Set includes four each .020", .010", and .002" shims and two .005" shims. Slots allow you to add or subtract the shims without pulling the dado set entirely off the saw arbor. Arbor size 5/8".

- 860-5000 Shim Set



Soft Arkansas Stone

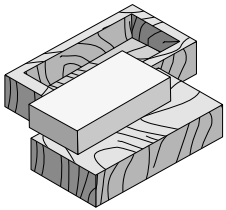

The soft Arkansas Stone is the best general purpose stone, and will quickly produce a sharp edge on your knives and tools.

- 340-1050 4" x 2" x 1"
- 340-1100 6" x 2" x 1"
- 340-1125 6" x 2" x 1/2"
- 340-1150 8" x 2" x 1"

Hard Arkansas Stone

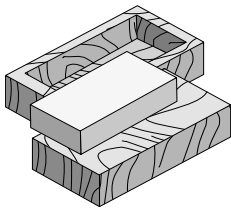

The hard Arkansas stone is for polishing an already sharp blade. Sharpening with this stone takes a little longer, but the exceptional edge is well worth it.

- 340-1200 4" x 2" x 1"
- 340-1250 6" x 2" x 1"
- 340-1300 8" x 2" x 1"

Black Hard Arkansas Stone

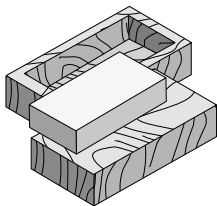

After an edge is prepared on a softer stone, the Black Hard Arkansas Stone is traditionally used as the final finishing stone. It provides a polished surface and reduced edge raggedness. It can be used to touch-up slightly dull edges but it is not meant for coarse grinding type applications. Definitive sharp edges require use of the Black Hard Arkansas stone.

- 340-1430 4" x 2" x 1/2"
- 340-1435 6" x 2" x 1/2"
- 340-1440 8" x 2" x 1/2"

Honing Oil



Honing Oil. This oil is the right "weight" for use with all oil stones.

Three ounce bottle.

- 340-2600 Honing Oil

Combination Arkansas Stone

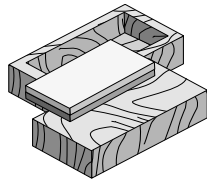

Begin sharpening on the soft Arkansas side, and finish the edge on the hard Arkansas side.

- 340-1450 4" x 2" x 1/2"
- 340-1500 6" x 2" x 1/2"
- 340-1508 8" x 2" x 1/2"

Soft/Black Combination

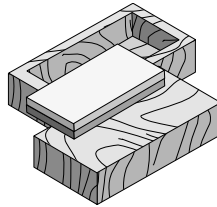

This combination stone offers the general-purpose qualities of a Soft Arkansas stone with the finishing capabilities of the Hard Black Arkansas stone. If you want just one sharpening stone, this combination stone is a good choice.

- 340-1530 4"
- 340-1535 6"
- 340-1540 8"

Pocket Stones

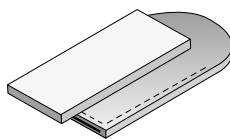

Natural Arkansas Stone in top grade genuine leather pouch. Excellent for small pocket knives.

- 340-1550 3" x 1" x 1/4" Soft
- 340-1600 3" x 1" x 1/4" Hard

Combination Stone

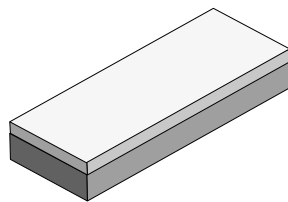

These rapid cutting stones will prove a pleasure to use. Coarse India on one side for basic sharpening and fine India stone on the other for the final edge.

- 340-1526 6" x 2" x 1"
- 340-1528 8" x 2" x 1"

Slip Stones

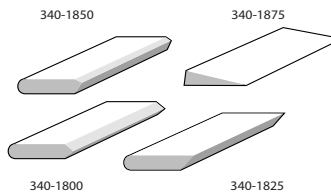

Four varied profile India slip stones for those hard to get angles and corners. All stones 2 1/4" x 7/8" x 3/16".

- 340-1800 Slip Stone - A
- 340-1825 Slip Stone - B
- 340-1850 Slip Stone - C
- 340-1875 Slip Stone - D
- 340-1900 Set of Four**

Round Edge Slip Stone

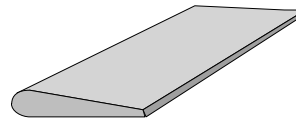

This round edge stone is for working with curved edges and for deburring and polishing. Excellent for woodcarver's tools.

- 340-1700 Soft Arkansas 4 x 2 x 1/2
- 340-1650 Hard Arkansas 4 x 2 x 1/2
- 340-1720 Fine India 4 1/2 x 1 3/4 x 3/8

Gouge Slip

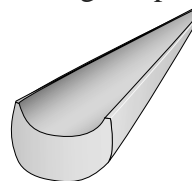

The one tool that no carver likes to be without when it's time to sharpen a gouge. Fine grit tapering India gouge slip is a must for anyone who needs to put an edge on a curved surface. Size is 6" x 2" x 1/2" x 3/8".

- 340-2000 Gouge Slip

Combo Slip Stones

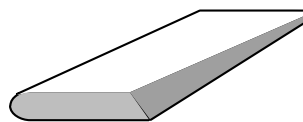

With different edge configurations, these stones will sharpen just about any carving tool from gouges to V-grooves. One edge is shaped round and tapers from approximately 1/8" to 1/2". The other edge is straight and has an angled taper. Stones measure approximately 2" x 4".

They are best used in conjunction with each other, with the Soft Arkansas as the first to be used followed by the Hard Arkansas to finish the cutting edge.

- 340-1775 Soft Arkansas
- 340-1785 Hard Arkansas

Sharpening Stone Materials

Arkansas stones are found in the state with the same name. Experts sort and grade this natural material carefully so that you will get the sharpening characteristics you expect. Still, some differences in color and other characteristics are to be found when comparing one stone with another. Arkansas stones have proven themselves to generations of tool users.

Arkansas File Set

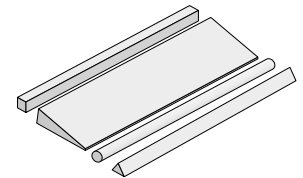

File Set contains the most used files for woodcarvers, gunsmiths, and machinist. Boxed for protection. Each stone is 4" long.

- 340-1750 File Set

Tri-Hone

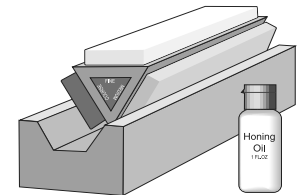

Quality edge tools cannot be properly sharpened with only one stone. You need a courser stone to start, and then work your way through finer stones for a truly sharp edge! Here are three oil stones mounted on a triangular cedar base so that you can easily work your way to a great cutting edge. Includes Aluminum Oxide stone (course), Soft Arkansas, and Hard Arkansas stones.

- 340-2550 6"
- 340-2580 8"

Sharpening Kits



Comes complete with a soft Arkansas, hard Arkansas, & bottle of honing oil—all in a plastic storage box. Great for all pocket knives and small hunting knives.

- 340-2500 Small
- 340-2525 Large



SHARPENING ACCESSORIES

Japanese Water Stones

A superior quality water stone, made to the finest Japanese specifications. These stones cut very fast, but still leave the finest edge! Stones need be soaked for thirty minutes before using, but can remain in the water indefinitely after the first use. This is a full line of quality sharpening stones for the serious woodworker.

Gouge Stones



Tremendously helpful stone is six inches long and tapers from 2 5/16" to 9/16". Makes sharpening gouges much easier.

- 705-4005Coarse 180 grit Gouge Stone
- 705-4010Medium 1000 grit Gouge Stone
- 705-4015Fine 4000 grit Gouge Stone

Bench Stones

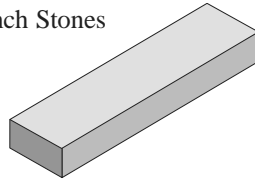

Start sharpening with a coarser stone, then proceed progressively to finer grits. For some, the 6000 grit finish stone will provide a perfect edge, while others will require the use of the still finer 8000 grit gold stone.

- Size 8 7/16" x 2 5/8" x 1 1/4"
 - 705-0800800 grit
 - 705-10001000 grit
 - 705-12001200 grit
- Size 8 1/2" x 3 7/8" x 1 1/2"
 - 705-20001000x6000 double sided
- Size 7 1/4" x 2 3/8" x 3/8"
 - 705-20106000 grit Small Finish
- Size 8 3/8" x 2 7/8" x 3/4"
 - 705-20406000 grit Large Finish
- Size 8 3/8" x 2 1/8" x 7/8"
 - 705-30008000 grit Gold Finish

Tool Sharpener



Three extremely useful and easy to use sharpening tools each with diamond sharpened tungsten carbide inserts. All feature the same comfortable-to-hold aluminum handle with incorporated guard and tapered head. Each of these tools comes with a pouch for storage and protection while not in use. Clearly worded and illustrated instructions are also included with each. Made in France.



Fitted with a V form solid tungsten carbide insert, where the tops of the V form the cutting edges and are used with a stroking action along the edge of the tool that requires sharpening. Excellent for sharpening axes, drawknives, scissors, scythes, shovels and any number of tools that do not need a polished razor's edge.

- 847-6100One Insert



Fitted with the same V form insert in solid tungsten carbide as the 847-6100 above, but on the other side of the tapered head, has a second insert, this one round with a diamond ground helical chip-breaker which is used after the V insert to remove any burrs and refine the edge. This second insert also works as a quick touch-up between sharpenings. Excellent for sharpening pocket, shop

or kitchen knives whether in stainless or carbon steel. With this tool a truly refined and polished edge can be achieved on most any tool.

- 847-6150Two Inserts

Makes burnishing easy! Diamond ground inserts in solid tungsten carbide make short work of preparing and turning the burr on even the hardest of cabinet scrapers, both curved and rectangular. The incorporated hand guard and the fact that the inserts are very near the hand permit the user to apply a strong and constant pressure with great precision. On one side, a round polished insert is perfect for "ticketing" or case hardening the scraper edge. This insert also is excellent for fine turning of scrapers. On the other side, a triangular insert with a polished acute angle is excellent for aggressive turning of even the thickest of scraper blades.

- 847-6200Burnisher



Nagura Stone

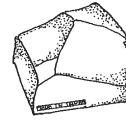

This carefully selected natural stone is used for creating a slurry on the surface of finish stones during sharpening procedures. Made in Japan.

- 205-6000Nagura Stone

Carving Tool Slip

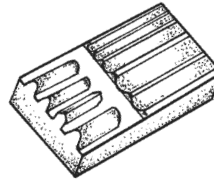

These 1000 grit waterstone slips have several shapes for sharpening all types of tools. The size of the stone is 150mm x 56mm x 25mm. Made in Japan.

- 700-9010Carving Tool Slip

Sharpening Strops



"Wood is Good" tool strops come in two sizes, and enables one to put that razor edge on cutting tools. The smaller strop is perfect for most carving tools, while the larger version was designed to give the space needed to sharpen plane iron blades. Both have 'rounded' and 'V' edges for those hard-to-sharpen shapes. Sizes shown are for the strop excluding handle. USA.

- 170-41001 7/8" x 7"
- 170-41503" x 9 1/2"
- 170-4200Abrasive (1 oz)

Resurfacing Stone



An 8" x 2 1/8" x 1" resurfacing stone comes with wide diagonal corrugations or channels and is designed for flattening waterstones. Typically well-used waterstones develop hollow areas and the stone's usefulness is then minimized. The resurfacing stone's coarse grit and the water/debris clearing diagonal channels can quickly return worn sharpening stones to a flat condition. Highly recommended.

- 705-5000Resurfacing Stone

Honing Guide



This product was originally designed for use with traditional Japanese tools, but can be put to good use with Western style tools as well. Great for flattening the backs of cutting tools. Made in Japan.

- 760-2050Honing Guide

Water Stone Base

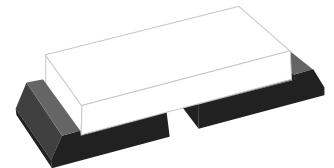

Here is a great solution to holding water stones securely during use. Rubber base consists of two parts which go on opposite ends of the water stones. Works like a charm. Made in Japan.

- 705-0010Stone Base

Stone Holder

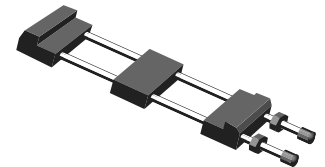

Great for diamond and Arkansas stones, this stone holder has rubber ends that hold the stone, as well as keep the stone from moving on your bench. Fits stones 5 1/2" to 9" long. Arms are chrome plated. Made in Taiwan.

- 825-2475Stone Holder

Wheel Dresser



In order to keep your grinding wheels in top-notch condition use this diamond tipped wheel dresser on a regular basis. Not only trues the face of the wheel, but cleans the face so that the grinding wheel will sharpen your tools faster and with less chance of burning the steel of the tool. Made in India.

- 885-5025Wheel Dresser



HONING GUIDE - HOCK TOOLS

Honing Guide

If order to get best performance from chisels and plane blades it is mandatory for them to be razor sharp. Sharpening requires a back and forth motion and, when holding the tool without a guide, it's impossible to maintain the same angle during this motion and impossible to know what the bevel angle actually is. This easy to use guide attaches to the cutting tool and the sharpening angle can be easily determined. With a simple rolling motion razor sharp edges are gained. When using, keep firm pressure on the cutting edge and less on the roller thus minimizing stone wear. Creating precise secondary angles are also a snap. For chisels up to 1 5/8" wide and plane blades up to 2 5/8" wide.

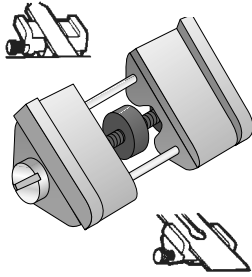

800-1800 Honing Guide

Two Cherries Sharpening DVD



An instructional DVD from Two Cherries covering the sharpening of chisel and plane blades, as well as a wide range of carving tool sweeps and sizes, from 1mm micro gouges to 3" fishtail tools, V-tools, and more. The sharpening methods demonstrated use only easy to find sharpening equipment and shop-made jigs. The techniques do not require the use of hard to find or expensive equipment. The instructor also shows how to repair and restore a damaged cutting edge. DVD can be played in English, Spanish, German, Dutch, or French. Approximately 73 minutes.

524-7500 Sharpening Video

Hock Bench Plane Irons

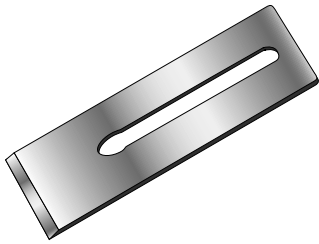

These single irons are replacements for most bench planes such as Anant, Foot-print, Stanley, etc. All are now available in A2 steel as well! High carbon steel blades can be honed easier and sharper, while cryogenically treated A2 blades will hold an edge longer.

Number	Fits	Width
110-3175	0 3	1 3/4"
110-3200	04-05	2"
110-3238	4 1/2-5 1/2-6-7	2 5/8"
110-3262	8	2 5/8"
110-0110	A2 Bench Plane Blade	1 3/4"
110-0120	A2 Bench Plane Blade	2"
110-0130	A2 Bench Plane Blade	2 5/8"
110-0140	A2 Bench Plane Blade	2 5/8"

Plane iron for a number ten bench rebate plane (sometimes called a Jack Rabbit).
110-3010 Iron for #10

Hock Double Irons

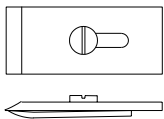

Extraordinary quality rarely found today. Great for producing your own wooden planes. All are double irons. Radius edged irons also available.

110-1100	1"
110-1125	1 1/4"
110-1150	1 1/2"
110-1175	1 3/4"
110-1200	2"
110-2125	1 1/4" (4"r) Radius-Edge Iron
110-2150	1 1/2" (5"r) Radius-Edge Iron
110-2175	1 3/4" (6"r) Radius-Edge Iron



The world's finest blades for hand woodworking tools for over twenty years! Hock Tools is a small metalworking cottage industry located in the middle of Mendocino's renowned woodworking enclave. For many years Hock tools have been handcrafted to satisfy the demands of the most discriminating professional.

Hock Wooden Spokeshave Irons

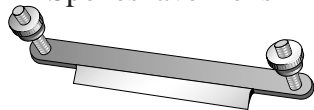

Two-threaded-post style spokeshave irons that lend themselves nicely to making your own wooden body spokeshave. Brass thumbnuts are included. The larger iron has a 2 3/4" cutting edge and is 4 7/16" x 5/8" overall. The smaller iron has a 1 1/2" cutting edge and is 2 1/2" x 7/16" overall. There is a wealth of information on the internet about wooden body spokeshaves. In particular, look for John Gunterman's TEACHSHAVE page for a lesson from the master.

110-7044	1 1/2" Edge
110-7062	2 3/4" Edge

Violin Knife

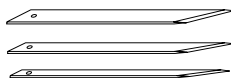

We offer three sizes of chip-carving blades suggested by the late master violin-maker, Hans Weishaar. These knives are beveled on both sides (not one side like a marking knife) and are sold as blades only, no handles. Hock Tools.

110-8025	1/4" X 7"
110-8050	1/2" X 7"
110-8075	3/4" X 7"

Hock Block Plane & Spokeshave Irons

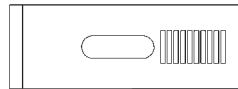

The highest quality replacement irons for block planes, spokeshaves, and radius-edge planes. All block plane irons and the adjustable spokeshave iron are now available in A2 steel!

110-4138	1 3/8" Plane Iron 7/16" Slot
110-4162	1 3/8" Plane Iron 7/16" Slot
110-4238	1 3/8" Plane Iron 5/8" Slot
110-4262	1 3/8" Plane Iron 5/8" Slot
110-0210	1 5/8" A2 Plane Iron 7/16" Slot
110-0220	1 5/8" A2 Plane Iron 7/16" Slot
110-0230	1 5/8" A2 Plane Iron 5/8" Slot
110-0240	1 5/8" A2 Plane Iron 5/8" Slot



110-7151	Adjustable Spokeshave Iron
110-0310	A2 Adjustable Spokeshave Iron
110-7175	1 1/4" Spokeshave Iron
110-7200	2" Spokeshave Iron

Hock Burnisher Rod

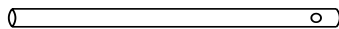

This 3/8" x 6" burnisher is hardened to Rc64 & polished to a mirror finish. For the woodworker wanting the finest quality in a burnisher, this is it. Handle may be easily fitted. (Hock)

110-1375	Burnisher
----------	-----------

Hock Marking Knife



This right-hand or left-hand, spear point marking knife (the bevels are on one side only) is perfect for scribing fine lines against a straight edge. Overall size is 1/2" x 1/4" x 7".

110-8575 Marking Knife by Ron Hock

Chip Breakers

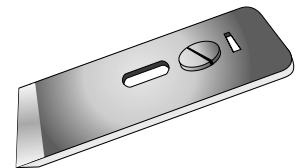

Upgrading the chip breaker in your old or new plane can be one of the best things that you can do to prevent chatter and tear-out. Available in three sizes, adding a Hock chip breaker to your planes will be a great investment in improving your work. Better yet, combine a Hock blade with one of these chip breakers - you will be glad you did!

110-3328	1 3/4"
110-3332	2"
110-3338	2 5/8"

Hock Scraper Irons



Two high quality scraper plane irons that allow you to upgrade your scraping tools quickly and easily. One is made for the Stanley #12 and #112 scraper planes, and the other for the #80 cabinet scraper. These blades have a forty-five degree bevel on the cutting edge. Hardened for a balance of long edge life and burr "rollability".

110-5080	Fits #80
110-5112	Fits #12 and #112



KUNZ SPOKESHAVES & PLANES



Pocket Planes

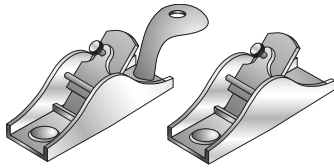

Both of these pocket planes are 3/2" long with a 1" blade. The raised handle model (sometimes referred to as a palm plane) is more comfortable to use for longer periods of time, while the plain pocket plane will fit into more and varied spaces. Handy for small, light work. The replacement blade will fit either models. These fine tools are made in Germany by Kunz.

- 580-2200 ..Pocket Plane Raised Handle
- 580-2300 Pocket Plane
- 580-2301 Blade Only

Bullnose Rebate Plane

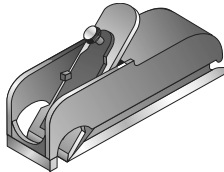

Bullnose rebating plane from the Kunz company of Germany. This is the classic model number 75 plane, 1 1/16" wide and 3 7/8" long.

- 580-2400 #75
- 580-2405 Iron for #75

Kunz Rebate Plane

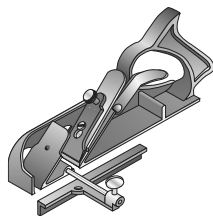

Rebating plane has a lever adjustment of the iron as well as a fence for guiding the work. In addition, the iron can be put into a front bullnose position.

- 580-2600 Rebate Plane
- 580-2605 Iron Only

Side Rebate Plane

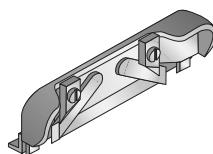

Side Rebate Plane #79 for right or left hand working. Nose pieces removable. Depth gauge. Blades can be individually set. Manufactured in Germany by Kunz.

- 580-2500Kunz #79
- 580-2501 Pair Kunz Iron Only

Spokeshaves

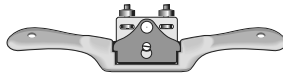

Kunz adjustable spokeshaves in both flat bottom and round-bottom versions. Every shop should have, at least, the flat bottom style -- which you will use. Blade fits both styles. Made in Germany.

- 580-1000.....Flat BottomKunz #151
- 580-1050.....Round Bottom Kunz #151R
- 580-1095 Blade Only



Spokeshave with hollow edge that is 10" long and fitted with a 2 1/16" blade. Certainly useful for working the wooden spokes of a wheel, but just as useful for the oars of a kayak as well!

- 580-1100Kunz #55
- 580-1105 Iron Only



Long out of production, this chamfering spokeshave with adjustments for various settings is once again being made by Kunz.

- 580-1700 Kunz #65



These spokeshaves are perfect for light work as might be found in miniature woodworking or model making. About 9" long overall with a 1 3/4" blade. Flat or round bottom model.

- 580-1400 Flat - Kunz #64
- 580-1500 Round - Kunz #63
- 580-1505 Iron Only fits #64 or #63

Cabinet Scraper

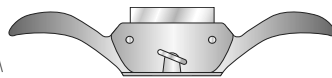

Cabinet scraper in the traditional #80 style will produce the finest possible surface. Use a burnisher for sharpening the blade.

- 580-2000Kunz Scraper #80
- 580-2005 Blade Only



Double spokeshave has a 1 1/8" hollow cutter and a 1 5/8" flat cutter. Depending upon the work that you are doing, this tool can speed things up a great deal! It certainly makes switching from flat to hollow spokeshave a breeze.

- 580-1300Kunz #60
- 580-1301 Iron only Flat
- 580-1302Iron only Hollow

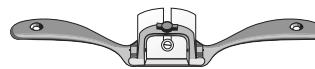

Spokeshave with adjustable mouth. This is the same spokeshave mentioned by James Krenov in the *Fine Art of Cabinetmaking*. If you are doing rough work, open the mouth to provide maximum clearance. If you are doing fine work, close the mouth for a finer cut.

- 580-1200 Kunz #53
- 580-1205 #53 Iron only



Comes with 2 1/16" iron. If you are doing hollowing work, you will find this spokeshave to be essential to your work.

- 580-1600 Kunz #50
- 580-1605 Iron Only



This may be called a cooper's spokeshave, but many woodworkers will find a wide variety of uses for this extra long spokeshave.

- 580-1800 Coopers #56 Spokeshave
- 580-1805 Blade Only

Circular Plane

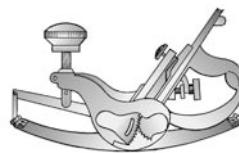

Circular plane with flexible steel bottom which can be adjusted to plane convex and concave surfaces. Kunz

- 580-2700Circular Plane
- 580-2705Iron for Circular Plane

Kunz PLUS Bench Planes



This plane combines all of the high-quality features of traditional bench planes, with innovative details and new design. The casting is stress-relief annealed grey-cast iron, and the iron is made from tool steel hardened to 60-62 HRC. It is seated optimally to prevent chattering. Easy and precise setting of the mouth opening is made by turning just a single screw. The sole is precision ground, and the sides are square to the bottom. Handle and knob are produced from native woods. Made in Germany

- 580-3300.....#3 Plus Smooth Plane
- 580-3400..... #4 Plus Smooth Plane
- 580-3500.....#5 Plus Jack Plane
- 580-3600.....#6 Plus Jack Plane

Replacement Irons

- 580-3310.....#3 Plus Iron Only
- 580-3410.....#4-5 Plus Iron Only
- 580-3610.....#6-7 Plus Iron Only

9 1/2 Block Plane



The one hand plane for every woodworker. This one has been improved with better finishing on the heavy-cast body. Other improvements include a substantial brass knob, cap with easy to use tightening screw and an adjustable throat which can be closed to a very small/fine opening. The blades are cut on a CNC machine producing cleaner, better blades. This is a block plane superior to others, and will be the one reached for over and over again. Made in Germany

- 580-4600 9 1/2 Block Plane

Scraper Plane



For the final finish operation on your wood, nothing can compare to scraping. This scraper plane is similar to a bench plane in style. Comes standard with a plain edge blade, but a toothed blade is offered as an accessory. Kunz

- 580-2150 #112 Scraper Plane
- 580-2155 Blade Only
- 580-2160 Toothed blade Only



SPOKESHAVES & PLANES

Clifton Spokeshaves

Clifton spokeshaves are made out of virtually unbreakable spheroidal graphite/malleable iron; the surfaces are finished and polished to give maximum comfort in the hand. These are not inexpensive tools, but neither are they compromised in any way.



635-6100Convex #500
635-6150Spare Iron for #500



635-6200Concave #550
635-6250Spare Iron for #550

Clifton Wedged Rebate Plane



A beautiful metal body plane with rosewood wedge to guarantee that the 3/8" blade is held securely. Body is machined from quality grey iron casting, accurately machined, and precision ground on the sole and sides. Overall length is 3 1/8"

635-4500 #400
635-4501Cutter for #400

Clifton Plane Irons and Cap Irons

Irons are hand forged of high carbon steel, and are nearly 50% thicker than normal blades. Used as a replacement iron in a standard metal body plane, you can be assured of the best cutting edge possible. For even better results, use in combination with the Clifton two piece cap iron below.

635-2134 1 3/4"
635-2200 2"
635-2238 2 7/8"
635-2258 2 3/4"

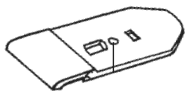

Two piece cap iron applies pressure specifically to the end of the plane iron. Two-piece cap iron facilitates honing of the cutting iron, as the lower part can be easily removed without having to lose the original cap iron setting.

635-1134 1 3/4"
635-1200 2"
635-1238 2 7/8"
635-1258 2 3/4"

Clifton 3 in 1 Rebate Plane

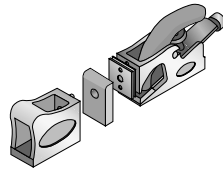

An extremely versatile tool, combining the features of shoulder rebate, chisel plane, and adjustable mouth bull-nose plane. The body is machined from a quality grey iron casting and precision ground on the sole and sides. Cutter is 1 1/8" wide, and overall length is 6"

635-3110 #3110
635-3111 Cutter for #3110

Clifton 5/8" Rebate Plane

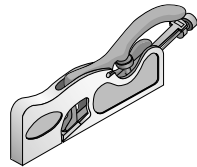

Tool provides a narrow, light, and accurate shoulder plane. Body is machined from quality grey iron casting, and precision ground on the sole and sides. Iron is 1/16" wide, and the overall length of this plane is 5 1/2"

635-4100 #410
635-4101 Cutter for #410

Clifton 3/4" Rebate Plane

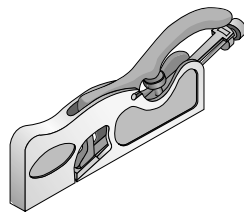

A light accurate shoulder plane. Body is machined from quality grey iron casting and precision ground on the sole and sides. Blade is 3/4" wide. Length is 8"

635-4200 #420
635-4201 Cutter for #420

HSS Round Burnisher

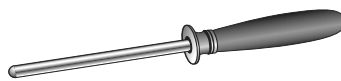

Clifton saw the need for an exquisitely designed and executed burnisher. The smooth high speed steel round blade will turn an edge easily. The wooden handle is comfortable to hold, and the brass extended shank protects your hand should you slip while turning the edge of your cabinet scraper. Made in England.

635-9700 Hss Round Burnisher

Miniature Planes

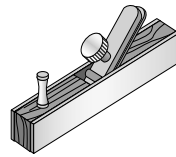

672-7050

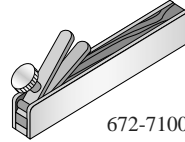

672-7100

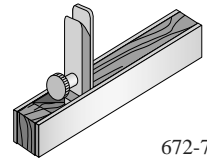

672-7150

Available in three distinct designs: block plane, bullnose plane and scraper plane. These are typically used when making models, jewelry boxes, doll houses and other fine items. They can also be used for delicate work on full-sized projects. Beautifully made of Rosewood and brass with 1/2" wide HSS blades. Each is under 3" in overall length. Made in India.

672-7050 Block Plane
672-7100 Bullnose Plane
672-7150 Scraper Plane

Radius Plane

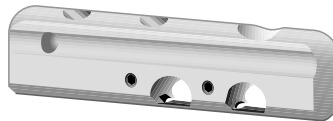

This is the easiest way to quickly radius the edge of your work. No need to set-up a router, simply reach for this radius plane and go to work. What makes this tool unique are the two carbide blades that make the cut. The leading blade takes off most of the material, while the second blade finishes the radius to a smooth finish. You will find yourself reaching for this tool over and over again.

825-5500 Radius Plane
825-5510 Pair of Blades Only

Scraper Holder

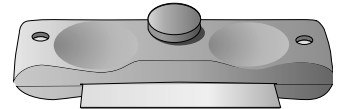

The Scraper Holder completely eliminates burned and tired fingers from intensive blade use. Made to fit all standard scraper blade thicknesses. Made in Taiwan.

825-6590 Scraper Holder

Block Plane Holster



Keep the block plane close at hand and free from tool box wear and tear. Whether using a ladder or out on the job side, this belt holster will keep the ever-needed block plane at arms reach.

845-1150 Block Plane Holster

Millimeters to Inches

Millimeters	Inches
1	0.039
2	0.078
3	0.118
4	0.157
5	0.196
6	0.236
7	0.275
8	0.314
9	0.353
10	0.393
20	0.787
30	1.181
40	1.574
50	1.968
60	2.362

Inches to Millimeters

Inch	Millimeters
1/32	0.8
1/16	1.6
1/8	3.2
3/16	4.8
1/4	6.4
5/16	7.9
3/8	9.5
7/16	11.1
1/2	12.7



PLANES

These planes, made in India, are nicely finished and will not destroy your budget! Spend a little time "tuning" these tools and you will neither regret your investment, nor the money saved. In fact, you might be able to consider getting an extra plane or two with the savings! Consider adding a Hock replacement iron and chip iron to upgrade an already fine product.

Bench Planes

The body of these planes are ribbed to ensure strength and rigidity. The machined faces of the frog bed sit firmly onto similar machined faces on the body of the plane and then fastened in position by two screws. This positive positioning helps prevent chattering. The cut iron is made of high carbon steel, hardened and tempered under scientific control for accuracy and uniformity. Handle and knob are hardwood.



The traditional finishing or smooth planes. The number four can also be used as an all purpose plane for a variety of work.
895-1300 Bench Plane A3 - Smoothing
895-1400 Bench Plane A4 - Smoothing



The number five plane is typically considered to be the "jack of all trades" and is the correct choice if you will only have one plane in your tool box.
895-1500 Bench Plane A5 - Jack
895-1600 Bench Plane A6 - Fore



These planes are long enough not to ride the peaks and valleys of your material making them the choice for flattening timbers.
895-1700 Bench Plane A7 - Jointer
895-1800 Bench Plane A8 - Jointer

Bench Rebate Plane

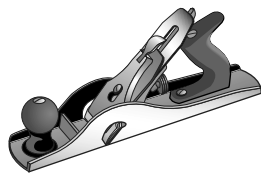

Same quality construction as the bench plane series. This thirteen inch long plane is fitted with a two inch wide blade that matches its two inch wide body. Recommended for general rabbeting work where a heavy section is being cut.
895-4100 Bench Rebate Plane A10

Circular Plane

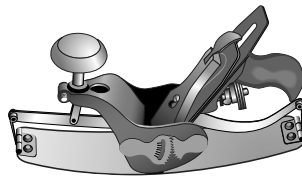

Designed for use on concave and convex surfaces. This plane features a flexible steel face that is anchored at each end to the body of the plane. Center screw adjustment enables the desired curvature of the sole to be set quickly and positively.
895-4200 Circular Plane A113

Plough Plane

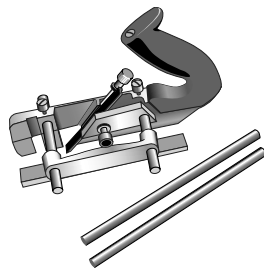

Ploughs nine sizes of grooves from 1/8" to 3/8" in width to a depth of 3/8" at any distance up to five inches from the edge of your work. There is a certain sense of satisfaction that one gets when using a tool that has been in use by generations of woodworkers. Wooden handle is comfortable to use. You may find that this versatile tool is easier and faster to use than setting up and using power tools for certain applications.
895-3100 Plough Plane A52 (8 Cutters)

Block Plane



This plane is fully adjustable and capable of fine accurate work. The screw adjusted cut iron is held firmly in position by a lever and cam. The mouth of the plane is adjustable for fine or coarse work.
895-2000 Block Plane A9 1/2

Bullnose Rebate Plane



This 1 1/2" inch rebate plane has an adjustable mouth that is adjusted by use of the provided shims. Removing the front turns this into a chisel plane.
895-4400 Bullnose Rebate Plane A77

Adjustable Spokeshaves

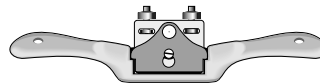

Spokeshaves offer smooth plane-like finishes and can be used on a variety of straight, flat and curved, concave and convex surfaces. Ideal for furniture makers and wood carvers. Easy to adjust.
895-1000 Flat Bottom
895-1050 Round Bottom

Multi Plane



This tool will perform a wide range of planing operations including ploughing, dadoing, beading, rabbeting, and slitting. Irons are set by means of a screw adjuster. Includes twenty-three irons as standard. Packed in a wooden box.
895-3000 Multi Plane A405 (23 Cutters)

Low Angle Block Plane



This is an indispensable plane for any woodworking shop. It can be used on plastic laminates, end grain, edges and touch-up work on any flat surface. The low angle blade is fully supported, thus minimizing annoying blade vibrations. It is accurately machined and finished with a durable high gloss stoving enamel. The cutter sits at 131/2 degrees. Overall plane length is six inches.
895-2500 Low Angle Block Plane 60 1/2

Rebate Plane

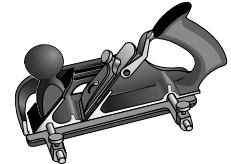

The model 78 rebate plane will cut accurate rabbets up to 1 1/2" wide. The adjustable fence is held in position by two fence arms. Bullnose blade position is provided for use when needed.
895-4300 Rebate Plane A78

#39 Rebate Plane

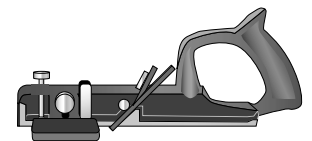

This traditional plane is eight inches in length and has a 1/2" blade which is the full width of the plane body. The blade is set at an angle for smooth cuts and features a screw adjustment depth gauge. Includes a depth stop.
895-4500 Rabbet Plane #39

Replacement Irons

These are the same irons found on the planes on this page. While you might not need a replacement iron for years to come, having a spare iron, already sharpened, can speed your work along when you would rather be planing than sharpening and honing.

- 895-9100 Spare Iron for Spokeshaves
- 895-9145 Spare Iron 45mm for A3
- 895-9150 Spare Iron 50mm for A4 & A5
- 895-9160 Spare Iron 60mm for A6 & A7
- 895-9166 Spare Iron 66mm for A8
- 895-9200 Spare Iron A9 1/2 Block Plane
- 895-9250 Spare Iron A10 Bench Rebate
- 895-9300 Spare Iron A78
- 895-9350 Spare Iron A77
- 895-9400 Spare Iron 60 1/2
- 895-9450 Spare Iron 39



JAPANESE SAWS

Flush Cutting Saw

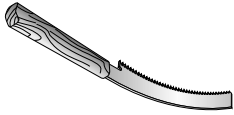

This flexible bladed saw is the perfect solution for trimming dowels or pegs. This tool will not mar the surrounding surface area.

720-3000 Saw

Small Tapered Flush Cut Saw



A flexible saw for flush trimming dowels and other small wood projections, the blade is meant for pulling towards the operator thus the blade is taut when in use. There is no set to the teeth so, used correctly, it will not mar the work surface. Approximately 8 1/2" in overall length with a 4" blade. It is 0.3mm in thickness with 26 teeth/inch and a 1.0mm pitch. Wood handle. Made in Japan.

770-4000 Flush Cut Saw

Azebiki Saw



The azebiki saw is a mortise saw capable of starting a cut in the middle of the board by using a series of rocking strokes with the curved blade.

720-4100 Azebiki Saw

Ryoba Saw

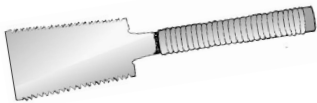

The Ryoba saw is a traditional Japanese carpenters saw. One side is used for rip cutting, the other for cross cutting. Handle is fully wrapped on all models. These saws cut on the pull stroke.

720-1200 Regular Quality
720-1210 Better Quality

Dozuki Saw



The Dozuki Saw is the traditional Japanese dovetail or joint cutting saw. No other saw can equal the fineness of cut, thinness of kerf, or accuracy of cut. The dozuki, as all Japanese saws, cuts on the pull stroke. Two saws available.

720-2100 150mm Blade
720-2200 240mm Blade

Replaceable Blade Saws

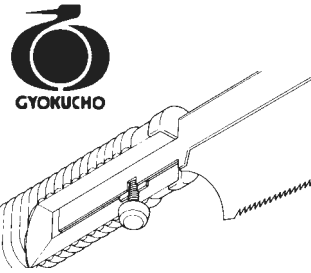

These replaceable blade saws combine modern and traditional design. Where indicated saws have hardened points -- giving extremely long life.

Ryoba (Carpenters Saws)



720-1500 240 mm - Hard Points
720-1505 Ryoba Noko Blade Only

Dozuki Saws

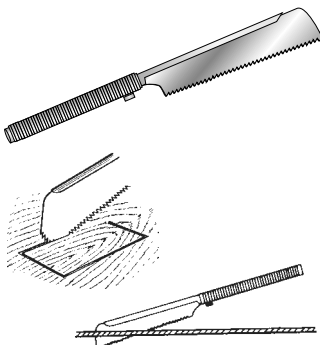

720-1550 240 mm - Hard Point
720-1555 Dozuki Noko Blade Only

Edo-Me Crosscut Saw

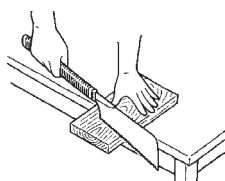

720-5600 ... Edo-Me ... 240 mm Saw
720-5605 ... Edo-Me ... 240 mm ... Blade Only

Keyhole Saw

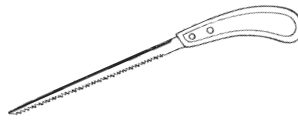

Very sharp teeth, cutting on the pull stroke enables this keyhole saw to do a fine job starting the cut from a small predrilled hole. Pull stroke cutting eliminates any buckling of the blade.

740-3100 Pistol Grip

Adjustable Keyhole Saw

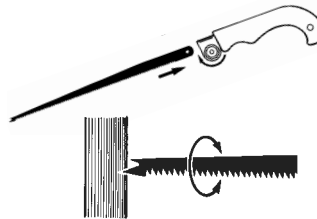

Nicely balanced tool with an adjustable blade. The very sharp teeth are designed to cut on the pull stroke, eliminating buckling of the blade while cutting. The specially designed tip allows you to "drill" into the material to start the cut.

740-3400 Keyhole Saw

Mini Saws



720-6510



720-6520



720-6530

Here is one of those "small can be better" situations . . . three small saws, all designed with a special purpose. If your work is smaller or perhaps a bit difficult to reach, one of these saws will work wonders. Pistol grip handles are comfortable to hold, and makes using these saws easier. Hole in handle is for hanging the tool when not in use.

720-6510 Green Wood Saw 120 mm
720-6520 Fine Cutting Saw 120 mm
720-6530 Keyhole Saw 105 mm

Razor Saws

These saws all share some basic design elements that make them a pleasure to use -- overall length of about 18" and a fantastic, comfortable, contoured plastic grip. All are modern variations of the traditional Japanese pull-stroke saw and each fills a specific need in the shop. Small kerfs and accurate cuts will result from the quality, balance, and design of these saws. Replaceable blades makes the maintenance of the saws very easy.



Use this dozuki saw for small joinery in most woods. Cuts a thin and straight kerf. Blade has seventeen teeth per inch.

770-3500 Dozuki with 0.3mm blade
770-3510 Dozuki 0.3mm Blade Only

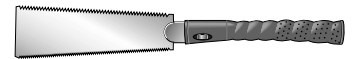

Perfect for cross cutting or ripping of smaller stock. Blade has seventeen teeth per inch on the cross cutting side and six teeth per inch on the rip side.

770-3600 Ryoba 0.5mm blade
770-3610 Ryoba 0.5mm Blade Only



Craft saw that is perfect for cutting plastics and hardwoods. Blade has seventeen teeth per inch.

770-3700 Craft Saw 0.3mm blade
770-3710 Blade Only

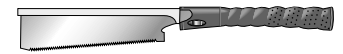

Excellent saw for the very finest cutting of small pieces of wood. Intricate joinery is possible with this twenty-five teeth per inch blade.

770-3800 Very Fine 0.3mm blade
770-3810 Blade Only

Beading Saw



Beading saw of traditional Japanese saw design makes finest cuts.

720-2900 Beading Saw



JAPANESE TOOLS - LARGER SCULPTING TOOLS

Awls



Mark the point where you will start to drill a hole, mark a line against a rule, or pierce a small hole in thin material. There are many uses in the shop for this awl.
730-2000 ... 3" Blade ... 5 1/2" OA..... Japan

Camilia Oil



Long used in Japan as a rust preventative measure. Pump spray bottle for easy use. An alternative applicator is also available which allows you to daub the oil on the tool rather than spray.
785-9000 8 ounce Spray Bottle
785-9100 Applicator Bottle Only

Oire Nomi Chisel Set



These are our finest chisels which are offered as a set only. They are produced using laminated steel construction for an edge that can hold an incredible sharpness (hard steel) and yet is backed up with a softer steel, giving tremendous strength. Set of five chisels includes 6-9-12-18-24 mm sizes. All chisels are between eight and nine inches in overall length.
710-1085 Set/5

Wood Carving Tool Set

Here are two great beginner woodcarving sets. Both sets are light duty and low cost. Choose between a set with a regular handle or one with a palm grip type handle. Both sets contain the same blade configurations -- two chisels, two gouges, a skew, and a "V" tool. If you want to do some occasional carving, or want to try out carving for the first time, either of these sets will be perfect. Overall length is about six inches on the regular handled tool set, and a bit shorter on the palm grip. Made in Japan.

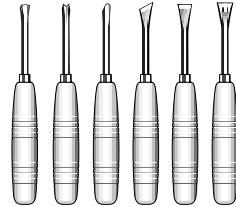

765-5000 Regular Handled Set of Six

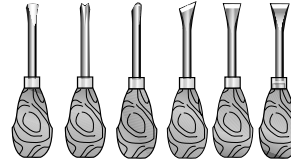

765-5100 Palm Handled Set of Six

Oire Nomi Chisels



These chisels are produced using laminated steel construction for an edge that can hold an incredible sharpness (hard steel) and yet is backed up with a softer steel, giving tremendous strength. All chisels are between eight and nine inches in overall length. All chisels have beveled sides, with the exception of the 3mm and 6mm chisels that have straight sides.

- 710-1003 3 mm
- 710-1006 6 mm
- 710-1009 9 mm
- 710-1012 12 mm
- 710-1018 18 mm
- 710-1024 24 mm
- 710-1030 30 mm
- 710-1042 42 mm

Leather Chisel Roll

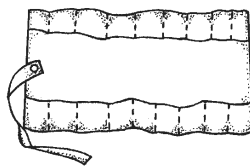

These leather chisel rolls are especially designed for Japanese chisels. Larger size is for longer chisels and measures twelve inches wide by eighteen inches long. Chisels can be up to about eleven inches in length. The smaller chisel roll measures nine inches by fifteen inches and will accommodate chisels up to about eight inches in length. Both rolls have pockets to accommodate ten chisels and a single leather strap to keep the roll closed.

- 780-1050 Large Size Chisel Roll
- 780-2000 Small Size Chisel Roll

Japanese Carving Tools

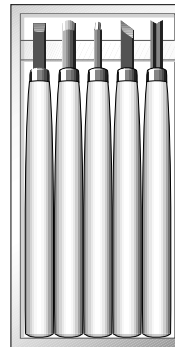

Economical set of five traditional style Japanese carving tools. Made of Yasuki special steel, the cutting edges are sharpened so that you can get to work right away. Comes in a fitted wooden case.
765-9100 Set of Five Carving Tools

Carver's Drawknife



This is the perfect size drawknife for the woodcarver! The razor sharp edge is 100mm (4") in length. A nicely made tool that is hot-forged and specially sharpened on felt wheels. Protective leather case is included. Quality forged out of quality steel and well finished! Made in France. Be certain to see the wide selection of other drawknives elsewhere in this catalog.
847-1050 Flat 100mm Drawknife

Carvers Spoon



This is a very useful tool for hollowing out your work. The tool itself is made of solid brass. You will find a tremendous range of uses for this tool. Made in Taiwan.
825-6550 Carvers Spoon

Wood Carver's Adze



Wood carver's adze are hand-forged from the toughest steel. Super keen edges and two sizes to choose from. Small adze has a 6 1/2" overall length head, while the larger head is 9". Curved blade on the small adze is 1", and the flat edge 1 3/4". Both blades on the larger adze are 2 3/4". Made in Austria.

- 310-1080 Small Carver's Adze
- 310-1500 Large Carver's Adze

Sculpting Adze

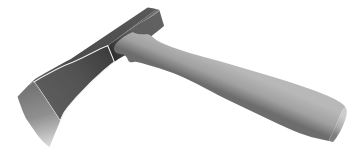

These efficient adzes are designed for the fast removal of wood. The Sculpting Adze's cutting edge is approximately 2 3/4" and is available in two sweeps. The wood handles are sized for balance and the proper striking motion. Use either adze for shaping large pieces. Made in Austria.

- 823-2004 70mm Blade Sweep 4
- 823-2007 70mm Blade Sweep 7

Riffler Rasp Sets

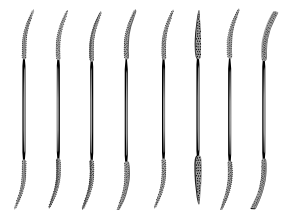

An economical set of riffler rasps for the beginner or occasional carver. Set of eight riffler rasps are made in China.
825-3600 Riffler Rasp Sets



CARVING ACCESSORIES

"Wood is Good" Mallet

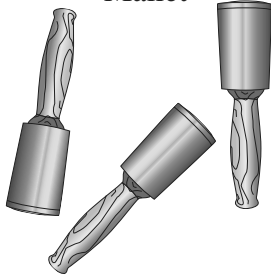

The "Wood is Good" mallet maintains the same hand grip on the wooden handle throughout the range of sizes-- twelve ounces through thirty ounces. A long lasting tool that does not harm the chisel handle, and is easy on the carvers hand and arm during extensive carving sessions. This is thanks to the synthetic striking surface that will absorb shock before it can get to your arm, and yet transmits the striking force to the tool. USA

- 170-101212 oz
- 170-101818 oz
- 170-102020 oz
- 170-103030 oz

Carvers' Mallets



Hardwood carvers' mallets of traditional design. Available in two sizes which can vary slightly between mallets.

- 310-1065 3" Head.....Small
- 310-1070 3 1/2" HeadMedium

Hand Guard

A protective guard for the entire palm, including the heel. Split leather pad can be worn under most gloves. One size fits all.

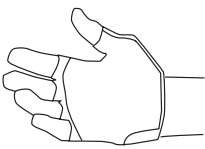

- 233-4010 Shock Pad.....Left
- 233-4030 Shock Pad.....Right

Kevlar Gloves

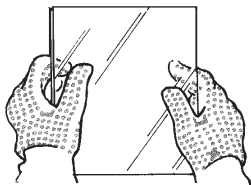

Kevlar®, the same Du Pont miracle fiber that makes police vests bullet-resistant, makes these gloves seven times more slash resistant than cotton gloves. They'll give your hands greater protection against slashes and cuts. Sold in pairs.

- 183-1000 Small
- 183-2000 Medium
- 183-3000 Large

Carving Stand

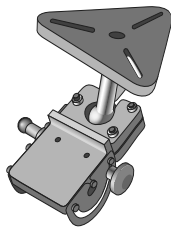

This is the perfect accessory for the serious carver. With this stand you can position your work in the absolute best position for accurate carving -- allowing you to do your finest work!

- 800-3650 Carving Stand

Wood is Good Tool Cases

These Wood is Good tool rolls and pouches are the perfect answer to tool storage needs!

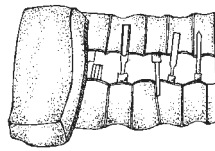

Choose from a simple six pocket or twelve pocket roll, or the twenty-four pocket vinyl or denim zip-up cases, or the twelve pocket roll made specifically for smaller tools.

- 170-2006 Tool Roll - 6 pocket
- 170-2012 Tool Roll - 12 pocket
- 170-1912 Small Tool Roll - 12 pocket
- 170-2100 Roll with Vinyl Case
- 170-2200 Roll with Denim Case

Thumb & Finger Guards



Comfortable fit provides controlled grip. Slip-on, hard-working, white grain leather guards. A must for carvers or anyone handling cutting tools on a regular basis.

- 233-1020 Thumb Guard..... Medium
- 233-2020 Finger Guard..... Medium
- 233-2500 Thumb & Finger Guard Set

Shock Pad

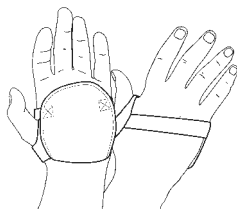

A reversible, split leather pad designed to absorb shock to the palm. Two wear surfaces make this pad suitable for either the right or left hand. One size fits all.

- 233-3020 Shock Pad

Dockyard Micro Carving Tools
 Made in the U.S.A. to exacting specifications. Each tool is mounted on a 3/8" diameter octagon handle of Cherry wood. The overall tool length is approximately five inches.

Micro Carving Tools



Set of five tools include plough, paring, 'V', 'U', and skew.

- 380-10003mm Standard Set
- 380-20002mm Standard Set
- 380-30001.5mm Standard Set

Micro Carving Tool Expansion Set



Five piece micro carving tool set contains tools in the 2.4 mm to 5mm size range.

- 380-6000 Expansion Set

Whittler's Apron

This very heavy duty denim apron has two permanent pockets and a very large pouch held with velcro so that you can empty out those shavings that inevitably collect. The pouch can also be kept open, giving the woodworker an extra long apron.

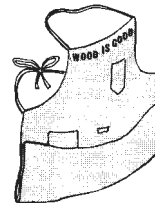

- 170-2300 Whittler's Apron

Micro Sculpture Set



Handy set of five tools. 2mm paring, 2mm 'V', and 2mm, 3mm, 4mm 'U'.

- 380-4000Sculpture Set

Micro Bench Chisels



Four carefully made micro dog-leg bench chisels -- 2mm, 2.4mm, 2.75mm, and 3.25mm.

- 380-7000Bench Chisel

Micro Gouge Set



Five useful gouges in sizes 1.5mm, 2mm, 3mm, 4mm, and 5mm.

- 380-5000Gouge Set

Carving Tool Roll

Denim tool roll will hold twelve of the Dockyard Micro Carving tools.

- 170-2410 Tool Roll

Magnifying Hood

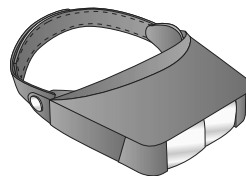

Lightweight, and with a wide-view, this magnifying headgear allows you to use both eyes at once for three-dimensional close-up viewing. Even fits over eyeglasses. Use the main lens for 2.2x magnification - quickly and easily lower the second lens to switch to 3.3x magnification. Especially useful for woodcarvers, this is the perfect answer for any type of close-up and intricate work.

- 665-1000Magnifying Hood

Whittling Kits

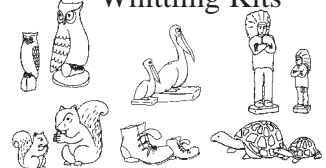

Created to show the way into the fascinating world of wood carving. Major facets are pre-cut, holes drilled, and, where called for, shoe laces, glass eyes, etc. are included. With EACH kit comes a small plastic model that shows how the kit should look when finished!

- 170-5010Owl
- 170-5020Frog
- 170-5030Indian
- 170-5040Pelican
- 170-5050Old Shoe
- 170-5060Turtle
- 170-5070Squirrel
- 170-5080Duck



PINCH DOGS - GLUING - CHECKERING - WOODBURNING

Glue Applicator

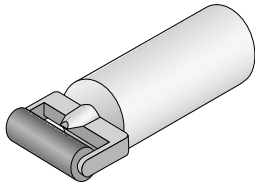

Fill the bottle with glue and you can easily apply a wide and even coat of adhesive. Application wheel is 2 3/8" wide and 1" in diameter. Bottle holds eight ounces of glue.

800-2855Glue Applicator

Glue Injector

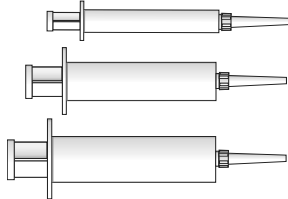

Plastic construction, these injectors can be used over and over again. Also useful for grease, oil, etc. Available in three different sizes, or in a set containing one of each. USA.

320-0500 Five 6 cc Injectors
320-1000 Five 15cc Injectors
320-1500 Five 30 cc Injectors
320-2000 Set of Three

Bellows Glue Applicator

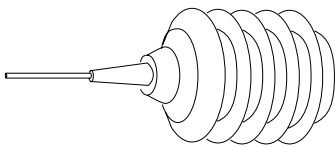

Designed for pinpoint gluing accuracy on detail work. One ounce bellows-style plastic body collapses with thumb pressure for easy glue control and placement. Stainless steel needle tip.

182-1000Glue Applicator

Glue Bottle With Brush



This is the easy way to apply glue. Gives you complete control in where you apply the glue on your work. The bottle holds approximately eight ounces.

825-4300Glue Bottle with Brush

Biscuit Slot Glue Bottle

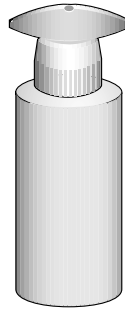

This glue bottle has a specially designed head that allows perfect application of glue into biscuit slots which makes the job quick and easy.

825-4400Biscuit Slot Glue Bottle

Glue Spreader Set

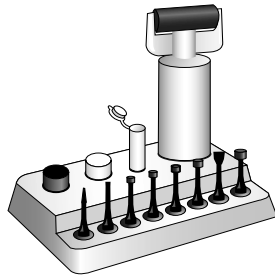

This kit gives you a complete gluing solution. The empty eight ounce bottle comes complete with a storage base block and a number of interchangeable heads (roller head, flat nozzle, pinpoint head, round head, five dowel heads). Includes wet well.

825-4375 Glue Spreader Set

Checkering Tools

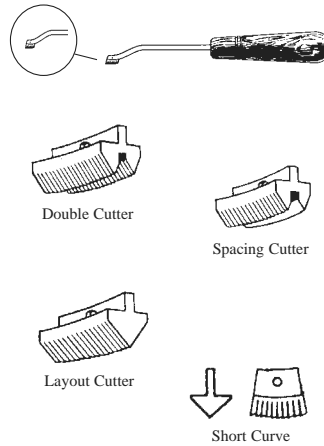

Starter set contains a complete S-1 tool, two regular handles as well as a fine layout cutter, coarse layout cutter, double cutter, spacing cutter, and a wide bordering cutter. The master set contains a fine layout cutter, coarse layout cutter, double cutter, left spacing cutter, right spacing cutter, and S-1 short cutter with a handle for each. (Dem-Bart)

153-4018Starter Set 18 lines/in
153-5018Master Set 18 lines/in
153-2500Checkering Instruction Book

Intarsia Knife

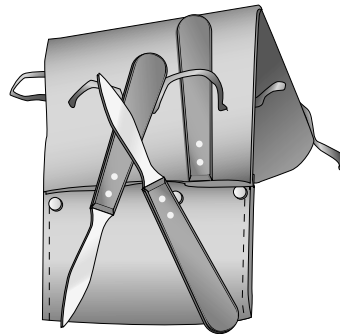

Intarsia takes exceptional skill and exceptional tools. These fine knives are designed for detailed, controlled usage, and hand comfort. The blades are razor sharp and feature blunt backs so that you can place your thumb against it for control and precise use. The set includes three knives — right hand bevel, left hand bevel, and double bevel. They have wood handles and come with a leather storage leather. In addition to their use for intarsia, they make great knives for carving. Made in France.

852-1000Trimming Knives In Case

Woodburner



This woodburner is the finest available. The tip of the tool is hot enough to burn wood, as the woodburner desires, and yet the handle stays cool. Lightweight, slim design, 64" cord, UL approved. The Dial-Temp provides infinite burning control, and allows the finest "shading". Temperature of 900 to 950 degrees without using the "dial-a-temp."

270-1000 Woodburner with one tip
270-3000Accessory Stand
270-2000 Dial-a-Temp

- 270-1005Standard
- 270-1010Needle
- 270-1015 Blank
- 270-1020 1/16" Circle
- 270-1025 1/8" Circle
- 270-1030 3/16" Circle
- 270-1035 1/16" Round
- 270-1040 1/8" Round
- 270-1045 3/16" Round
- 270-1050Button Tip
- 270-1055 Multi Groove Tip #44
- 270-1060 Multi Groove Tip #56
- 270-1065 Long Blank Tip
- 270-1070Knife Blade Tip
- Not Illustrated
- 270-1075Soft Feather Tip
- 270-1090 Stencil Tip

Pinch Dogs

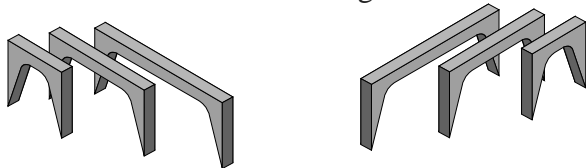

Pattern and cabinet maker steel pinch dogs. Square corners over the legs make for easy driving. Makes it a breeze to pull any two boards together. You will find endless uses for these reusable clamps. For instance, if you are installing wainscoting in a room and need to pull together the boards, these are the perfect solution. Use one pinch dog at the top and one at the bottom of the two pieces exactly where you will later install moulding that will

cover the small holes produced while using the pinch dogs. Keep a few of each size handy for those unexpected clamping needs. Made in the USA.

160-3003 3/4"
160-3004 1"
160-3005 1 1/4"
160-3006 1 1/2"
160-3008 2"
160-3010 2 1/2"
160-3011 2 3/4"
160-3012 3"
160-3014 3 1/2"



SAWS

Coping Saw Frames

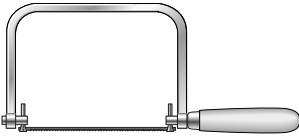

Blade can be adjusted to any angle, providing the best approach to your work. The tension is adjusted by means of turning the handle, and the saw frame accepts standard coping saw blades with pins. A quality tool that will last for many years. Blades for both metal and wood can be found below. This nicely made tool is from Germany.

540-2000 Coping Saw Frame

Coping Saw Blades



High quality coping saw blades with pinned ends. Fits our 540-2000 coping saw. Made in Germany.

540-7500 12 Blades for Wood
540-7550 12 Blades for Metal

Jeweler's Saw Frame

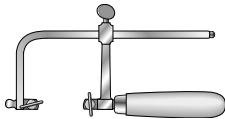

Solidly made saw frame with wooden handle. Broken saw blades can be accommodated by means of the back adjustment. The saw blades below are designed to be used with this frame. Made in Germany.

540-4000 Jewelers Saw - Adjustable

Jeweler's Saw Blades



Top quality hardened saw blades for precision work in cutting gold, silver, bronze, and other precious metals. Blade length is 130 mm. Reference #0 is the larger blade in the selection while reference #8/0 is the finest blade of the selection. Use these blades in our jeweler's saw frame 540-4000. Package of twelve blades. Made in Germany.

Teeth Per Inch	Ref #
830-4003 55.9	0
830-4203 61.0	2/0
830-4303 66.0	3/0
830-4403 71.1	4/0
830-4503 76.2	5/0
830-4603 81.3	6/0
830-4703 86.4	7/0
830-4803 88.9	8/0

Fret Saw Frame

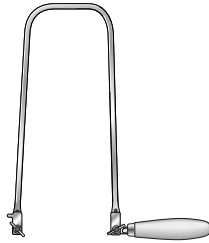

Quality fretsaw frame for accurate fretwork, marquetry, or other intricate and detailed work in thin material. Blades are securely held by clamps on each end. One of the easiest ways to hold your work while using a fretsaw is to clamp one of our fretsaw boards (also on this page) on your bench. Place the work on top of the board and use the saw in a vertical motion. Has a wooden handle. Made in Germany.

540-1000 Fretsaw

Fret Saw Blades



This is a popular and useful style of blade. Perfect for use in the fretsaw frames shown on this page. The teeth are designed for cutting wood, and are hardened for long life. Blade length is 130 mm. The smaller reference number (#0) is the finer blade, while the larger reference number (#12) is the biggest blade in the selection. These blades can also be used in a fretsaw machine. Package of twelve blades. Made in Germany.

Teeth per Inch	Ref #
830-1003 27.0	#0
830-1013 25.0	#1
830-1023 22.5	#2
830-1033 20.0	#3
830-1043 18.0	#4
830-1053 17.0	#5
830-1063 16.0	#6
830-1083 14.0	#8
830-1103 12.0	#10
830-1123 9.5	#12

Fretsaw Boards

Clamp one of these fretsaw boards on your bench then place the work on top of the board and use the saw in a vertical motion.

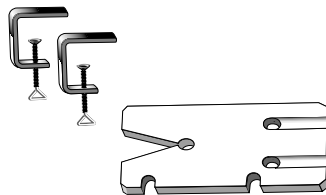

This fretsaw board makes use of two clamps for secure fastening to the bench. Made in Germany.

540-4750 Board with two clamps

Junior Saws

These saws are meant for all-around use in the shop and in the home. Whichever model you choose, you will find a multitude of uses for it. The blades are designed to cut metal, wood, and plastics. High quality German product.



540-3100 Wire Frame



540-3200 Wood Handle

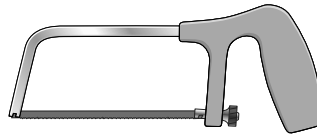

540-3300 Plastic Handle

Junior Saw Blades

Package of junior saw blades to fit all saw frames above. Choose between blades for metal or wood. Made in Germany.

540-8550 12 Blades for Metal
540-8500 12 Blades for Wood

Blade-Gard

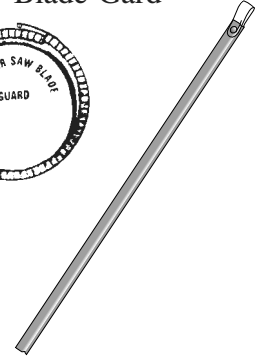

Nothing is so frustrating as having a newly-sharpened saw get accidentally damaged. With Blade-Gard your hand and circular saw blades are protected the moment you snap them on. Hand saw guard for saws up to 26" and circular saw guard for blades to 10". Made in the USA.

150-5000 Hand Saw Guard
150-6000 Circular Saw Guard

Sliver Gripper

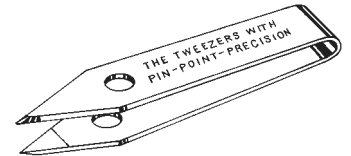

Uncles Bill's "Sliver Gripper" is one of the most important tools for any woodworker. The precise design and construction of these tweezers make them work where others cannot. USA.

300-1000 Sliver Gripper
300-2000 Sliver Gripper for key chain

Miter Box and Saw

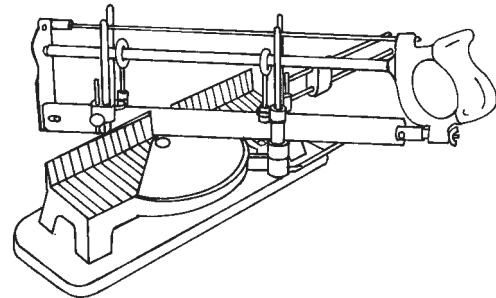

You can use this precision miter saw for cutting four, six, or eight angle frames and profiles in wood, aluminum, iron, or synthetic materials. The table is pressure cast and the four guide rods guarantees exact and solid work. The saw is equipped with standard wood cutting blade. Replacement blades available.

800-2800 Mitre Box and Saw
800-2814 Mitre Box Saw Blade 14 tpi
800-2830 Mitre Box Guide Rod— Steel
800-2831 Setting Deeply Saw Cut
800-2832 Long Clamp
800-2833 Short Clamp
800-2834 Saw Guide



MITER CUTTING - CLAMPING

Mitre Cutter

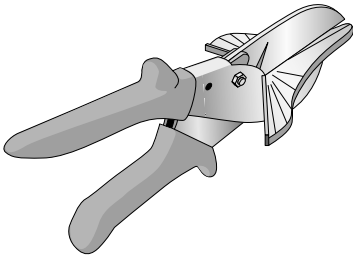

This is an essential tool for any woodworker or tradesman who needs to cut forty-five degree mitres in small mouldings on a regular basis. Base also



has markings for cuts of fifteen degrees, thirty degrees, and ninety degrees. Similar to a garden shear, the built-in fence allows you to cut mitre joints quickly, easily, and with accuracy. Not only used by hobbyists, this tool has an essential place in many trades from finish carpenter to concrete former. Makes quick work of cutting shoe moulding and chamfer strip. Made in Germany.

- 815-1000 Mitre Cutter
- 815-1025 Compound Action Cutter
- 815-1050 Replacement Blade
- 815-1060 Replacement Base

Mitre Trimmer

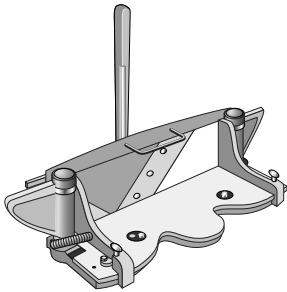

Miter trimmer makes perfect miters up to four inches, and when squaring stock up to six inches. Both right and left cuts can be made at angles between forty-five degrees and ninety degrees. The ground base surface and two razor-sharp knives offer controlled shaving and leave a glass smooth finish on the stock. This is the perfect tool for the picture framer, but is useful anywhere that a "perfect" mitre is necessary. Made in Taiwan.

- 800-3500 Miter Trimmer
- 800-3510 Pair of Blades Only
- 800-3525 Left "Wing" Only
- 800-3530 Right "Wing" Only

Frame Clamp

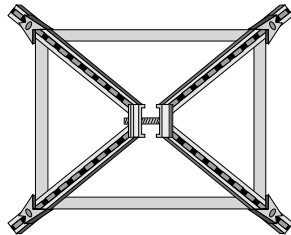

Quickly and accurately clamps a frame from 5" x 7" to 26" x 30". All four corners of the frame are clamped at one time, and equal pressure is applied to all joints. Aluminum railings with glue resistant plastic jaws.

- 800-2880 Frame Clamp

Mitre Vise

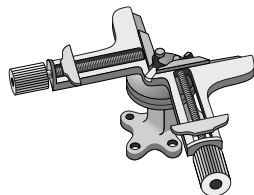

Clamps your work in position for perfect miter joints. Vise tilts from 0 to 90 degrees, rotates 360 degrees, and has 4" jaw openings. Five holes in the base allows for secure mounting to the workbench.

- 800-3600 Miter Vise

Picture Frame Brad Set

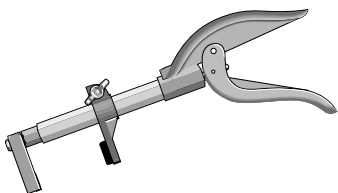

Installing those small nails on the backs of picture frames can be a laborious and frustrating job -- this tool takes care of it with ease. Position the nail where it is needed and squeeze it home with this clever tool.

- 190-1000 Brad Set

The Original Mitre Clamps



Mitred corners are one of the most difficult joints to clamp in all of woodworking. This very efficient mitre clamp system is like no other clamping method. It draws the two mitred pieces together and effectively holds them together with powerful spring-like rings. The rings have sharp points that do not drift or move once they are positioned. There are six ring sizes (A-F) for various sized workpieces. Ideal for picture frames, moulding, decorative trim and other mitre-type assemblies. The rings must be installed with the special application tool. Both sets come with application tool, and eight each of all ring sizes. Made in Germany.

Mfg Nbr	Capacity
560-3130	Mitre Ring A 3/8" to 5/8"
560-3140	Mitre Ring B 5/8" to 1"
560-3150	Mitre Ring C 3/4" to 1 1/4"
560-3160	Mitre Ring D 1" to 1 3/4"
560-3170	Mitre Ring E 1 1/2" to 2 1/4"
560-3180	Mitre Ring F 2 1/2" to 3 1/2"
560-3100	Application Tool Only
560-3190	Complete Kit
560-3250	Kit In Wooden Box
560-3275	Wood Box Only

Small Mitre Clamp Kit - The Original

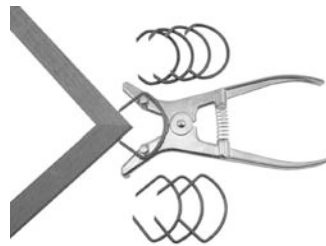

Made to meet the needs of carpenters, furniture restorers, boat builders, wood carvers and others with tricky clamping needs. It is ideal for securing mitered picture frames, crown moldings, corner baseboards, door and window casings and other finished and trim carpentry needs. The kit includes the same mitre clamp tool as shown above and is packaged with the most commonly used ring sizes. Kit comes with clamp tool and four each high-strength spring

steel B and D rings. With these two ring sizes molding widths from 5/8" to 1 1/4" can be clamped. Other ring sizes can be purchased separately.

- 560-3300 Miter Clamp with Eight Rings

Band Clamp

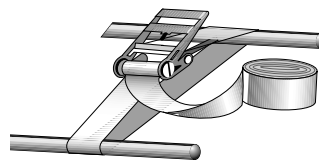

The one inch wide nylon web band is tightened by a ratcheting action that needs no tool to operate. The clamp can exert a pressure of 1500 pounds. You will find that this band clamp will easily help you in gluing up chairs, circular glue-ups for turnings, and other uneven clamping situations that bar clamps and other clamps will not handle.

- 825-1575 25' Band

Mitre Clamps

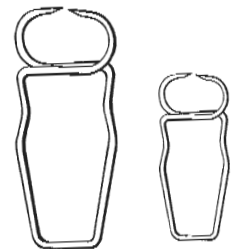

Open these clamps by squeezing with your fingers, then apply to mitre joint. Extremely handy. Use small for mouldings up to 5/8" and large up to 1". Made in Germany.

- 560-3050 Small
- 560-3060 Large



POWER TOOL ACCESSORIES - MISCELLANEOUS

Threadbox & Tap

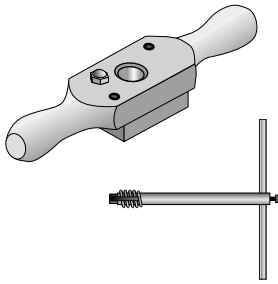

Nicely made wooden thread box for cutting threads on wooden dowels. Each size of thread box comes with a matching tap to complete the set. Available separately are bottoming taps that carry the threads produced by the standard tap nearly to the bottom of blind holes.

- 800-1008 Threadbox & Tap 1/2" x 8 TPI
- 800-1012 Threadbox & Tap 3/4" x 6 TPI
- 800-1016 Threadbox & Tap 1" x 6 TPI
- 800-1020 Threadbox & Tap 1 1/4" x 6tpi
- 800-1024 Threadbox & Tap 1 1/2" x 6tpi
- 800-1208 Bottoming Tap 1/2" x 8 TPI
- 800-1212 Bottoming Tap 3/4" x 6 TPI
- 800-1216 Bottoming Tap 1" x 6 TPI
- 800-1220 Bottoming Tap 1 1/4" x 6 Tpi
- 800-1224 Bottoming Tap 1 1/2" x 6 Tpi
- 800-1090 Cutter only for Threadboxes

Saw Step Gauge

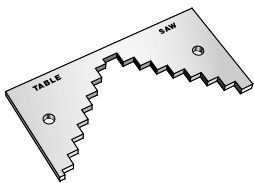

Makes accurate setup of table saws, radial arm saws, and other shop tools a quick and easy process. Gives an exact setting instantly!

- 825-3275Saw Step Gauge

T-Track

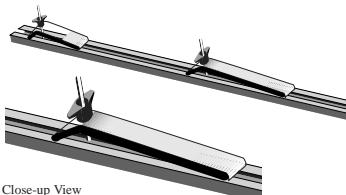

Close-up View

Fit this track in tool bases or into jigs and fixtures to save a tremendous amount of set-up time. Hold-down fits easily into the aluminum T-track and is secured by a knob. Track is available in three lengths and comes with hold-downs. Extra hold-downs are available as shown below. Imported.

- | Number | Track Length | Hold-Downs |
|----------|-----------------|------------|
| 825-3150 | 24" T-Track | 2 |
| 825-3175 | 36" T-Track | 3 |
| 825-3200 | 48" T-Track | 4 |
| 825-3125 | Extra Hold Down | |

Wooden Feather Board

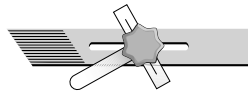

Handy when ripping long pieces of narrow stock. Fits into your miter gauge slot and locks securely. Puts pressure on the work to keep the work where you want it to be. Board is 10 7/8" long, 1 3/4" wide, and 7/16" thick.

- 825-1425 Wooden Feather Board

Feather Board

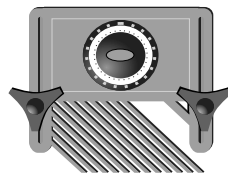

Lock this safety device into a standard mitre slot. Not only will it make your process safer, but it will increase accuracy. Adjustable through four and one-half inches of movement. Overall size is 9/16" thick, 1 1/4" wide, and 10" long.

- 825-1450 Feather Board

Fence Hold-Down Feather Board

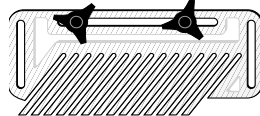

Use the fence hold-down featherboard on table saws, band saws or router tables and keep your hands clear of the tool's cutting action. By attaching the featherboard to a fence, adequate downward pressure is provided to keep the workpiece secure. Adjustments are made via two star knobs with bolts and two slots for screws. Size is 7 1/4" x 3 1/4" x 1/2".

- 825-6050 Hold-Down

Tapering Jig

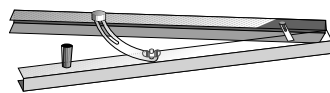

Twenty-four inch aluminum jig is reversible for right or left hand use, and adjusts up to fifteen degrees (three inches per foot). Designed so the jig rides up against your fence while the tapered side of the jig hooks the edge of your piece.

- 825-1150 Tapering Jig

Drill Gauge

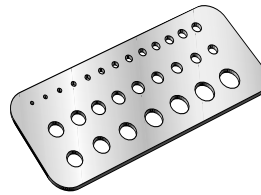

Gauge provides a quick and easy way to check the size of drills and other small round material. High quality steel with chrome finish.

- 885-2075 Drill Gauge

Depth Stops

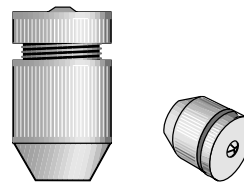

All you do is pick the correct stop for your bit, then adjust it to the desired depth of hole. Non-marring plastic for use with nearly all type bits.

- 800-2300 Set of 2

Pantograph

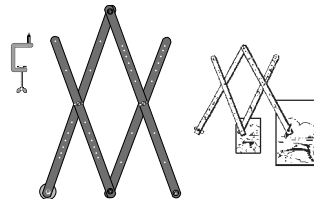

Enlarge or reduce your original art, plans, and projects, with this sturdy all metal device. Made in Japan.

- 730-1090 Pantograph

Oval & Circle Drawing Jig

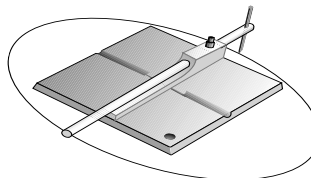

Woodworking is not always about square corners or mitre joints. Sometimes you need to layout a circle or an oval for that special project you are working on. This layout tool will draw circles from eight inches to twenty-four inches in diameter, as well as ovals from eleven inches to thirty inches (measured on the longer axis).

- 825-5250 Oval/Circle Drawing Jig

Router Depth Gauge

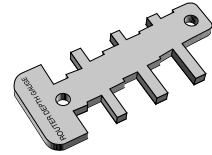

Quickly and accurately set your router to more than a dozen depth settings without the need for trial and error testing.

- 800-2100 Router Depth Gauge

Router Bit Centering Gauge

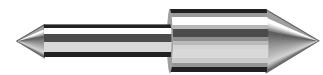

No need to worry where your router bit is going to cut using this nicely machined gauge. Fits 1/4" and 1/2" router. Overall the gauge is three inches long.

- 825-3350 Router Bit Centering Gauge

Router Bushing Set

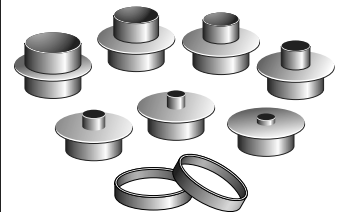

Brass template set will fit all Porter Cable routers or other routers that will accept a two piece template guide bushing. Set includes seven assorted template bushings plus two lock nuts in a plastic case.

- 825-2550 Brass Router Bushing Set

Corner Chisel

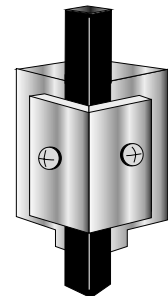

Use your router first to remove most of the material for a hinge mortise, then place this self-aligning chisel up against each mortise corner, and hammer the spring-loaded chisel shaft once to cut a perfect 90° corner for a perfect-fitting hinge plate. Cutting of 3/8" will work to a depth of 3/8".

- 800-1400 3/8" Corner Chisel



DRILLING JIGS - POWER TOOL ACCESSORIES

Self-Centering Doweling Jig

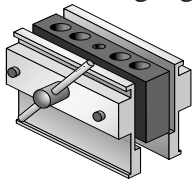

Doweling jig features automatic self-centering action to assure accurate center drilling every time, even on round objects. Two threaded holes, on 3/4" centers, accept drill bushings of 1/4", 5/16", and 3/8" (two of each included). In addition, there are two permanent drill holes in 7/16" and 1/2" sizes. Jig has a two inch capacity, and drill guides are hardened for years of use. Made in Taiwan

800-4000 Self-Centering Doweling Jig

Wood Baller Set

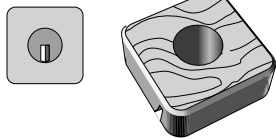

Set of three wood ballers that quickly round the end of a dowel. The end results are much like the ends on common household brooms, but there is no lathe work or manual shaping with rasp or files. Set includes tools for 1/2", 3/4", and 1" material.

800-2895 Wood Baller Set

Dowel Sizer



This simple tool will accurately size wood. Use on a slightly oversized dowel, or start with a roughly sized blank with all the corners removed. Set contains 1/2", 3/4", and 1" sizes.

800-2885 Dowel Sizer Set

Precision Drill Guide

This is an accessory that every drill owner should have. Perfect for repetitive and accurate drilling, it will also allow you to do work that is impossible to do by hand alone. Round stock is automatically centered in a V-groove.

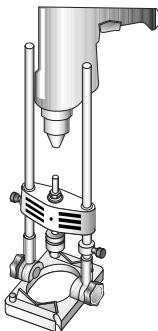

825-4200 Precision Drill Guide

Ball Bearing Rollers

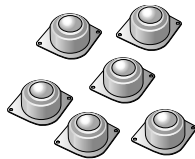

You will think of a multitude of uses for these handy ball bearing rollers. A common use would be to make your own infeed/outfeed table for table saws, finishing tables, and assembly lines. The 16mm (5/8") rollers will carry a 55 pound load and the 25mm (1") rollers a 77 pound load. Only your imagination will limit the uses you will find for these rollers.

800-2725 Set of Six 5/8" Rollers
800-2735 Set of Six 1" Rollers

Wood Pointer

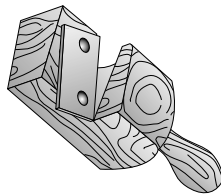

Easily and quickly apply a taper to the end of dowel. This wood pointer has a capacity to accept material up to 1" in diameter. Material does not need to be perfectly round to work in the tool.

800-2890 Wood Pointer

Dowel Former

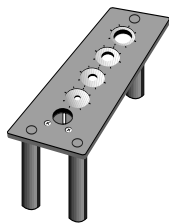

Using this tool with regular dowel rod to make tight and precise fitting dowel pins in 1/4", 5/16", 3/8", and 1/2" sizes. Flutes produced in the wood are compressed, not cut, and will expand when glued in place for an exceptional fit.

800-3000 Dowel Former

Double Pocket-Hole Jigs

Both styles make it convenient to drill two pocket holes with only one positioning of the jig. Perfect for face frames, cabinet doors, etc.

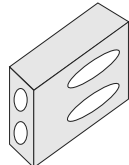

Non-adjustable holes on 3/4" centers.
800-2210 Nonadjustable Jig

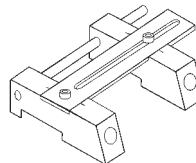

Adjustable from 3/4" to 3" centers.
800-2220 Adjustable Jig

Brass Bar Setup Gauges



You can keep the most commonly used measurements handy with this tool. Three precision machined brass bars (0.0003" tolerance). Gauges are 1/4" x 3/16", 1/2" x 1/16", and 3/8" x 1/8". You can even stack them together for additional sizes.

825-3250 Brass Bar Setup Gauges

Cutterhead Setting System

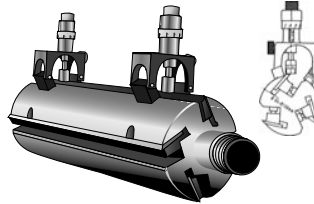

Simplify setting and adjusting knives in a cutterhead by stabilizing the knife blade. This system consists of two gauges each within a framework featuring strong magnets for firmly attaching to a cutterhead. Each of the adjustable gauge/frameworks also has a magnet for holding the knife. Simply place the gauge assembly over the knife and then adjust for the correct knife height. Both hands can then be used to tighten the cutterhead locking bar while the magnets hold the knife.

825-3550 Cutterhead Setting System

Drill Guide Kit

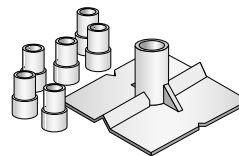

This is the easiest way to make sure you drill straight and true holes in a wall, on a flat surface, edge, cylinder, or sphere. Pop a bushing into the plastic guide and you are set to go. Centerpunch-locator tool is included. Includes bushings for 3/16", 1/4", 5/16", 3/8", 7/16", and 1/2" bits.

800-2860 Kit

Shelf Pin Drill Jig

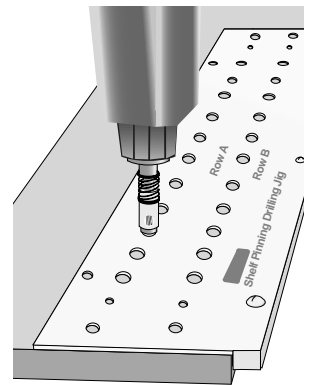

Great accuracy and speed for all of your shelving projects. This jig precisely spaces shelf pin holes 1/4" apart as well as 37mm or 64mm from the edge. In addition, simply index the 20" long template with a shelf pin and extend the range of this jig for any length run of holes. Use with either face frame or frameless construction. Comes with a 1/4" self-centering bit.

825-6585 Shelf Pin Drilling Jig
825-6586 1/4" Self-Centering Bit Only
825-6587 5mm Self-Centering Bit Only

"V" Center Jig

The troublesome nature of drilling squarely into round objects is eliminated with the V Center Jig. Attach it to a drill press table or other stationary surfaces for right angle and centered drilling. Also, use it to hold dowels and round stock for hand sawing. Made of aluminum.



825-4250 V Center Jig

Drawer Pull Installation Jig



A simple, no-fuss clear acrylic jig for locating and marking drawer pull locations. Using the adjustable fence, set the jig from the drawer's top edge, align the center line with drawer's center and mark pull's location.

825-5400 Drawer Pull Installation Jig



LUBRICANTS - FRET SAW BLADES - HOLD-DOWNS

Bostik Lubricants

GlideCote

GlideCote is the most sophisticated table top coating available. Use GlideCote to seal metallic table tops and to protect tools against corrosion. Also minimizes friction, is anticorrosive and dries rapidly.



278-3110 ...GlideCote... Aerosol..... 10.75 oz

BladeCote

BladeCote is rapidly becoming the woodworking industry standard for on-the-job coating of cutting tools. Reduces friction thereby lowering cutting temperatures and prolonging tool life. Heat resistant to 550 degrees Fahrenheit.



278-1110...BladeCoat .. Aerosol..... 10.75 oz

Bearing Lubricant

Bearing Lubricant is especially effective on router bit bearings or to lubricate slides and other high-load parts.



278-2500Bearing Lube Aerosol 5.5 oz

Bandsaw Blade File



This handy Bandsaw Blade File is used to smooth and round the back edge of a bandsaw blade. Roundness on a bandsaw's back edge allows radius cutting without the blade's back edge scoring into the just-cut wood. The handle is cross sectionally square so it's perpendicular to the blade when positioned on the bandsaw table and the handle length is so that the operator's hands are away from the moving bandsaw blade.

825-6025Bandsaw Blade File

Multi-Teeth Blades



This 13cm blade is especially good for coping and fine cutting on high performance machines. Reversed pairs of teeth allows cutting on both the forward and backward stroke. Teeth are also spaced to allow sufficient clean-out of the material that has been cut. Blade can be mounted in either direction. The larger the number, the wider and thicker are the blades. Twelve blades per package. Made in Germany.

830-6100#2/015 tpi
830-6201#115 tpi
830-6203#313 tpi
830-6205#513 tpi
830-6207#710 tpi
830-6209#98 tpi
830-6212#128 tpi

Reverse Tooth Blades



These blades have a number of reverse teeth that produces a splinter free finish on the top of your work, and on the bottom as well. This 13cm long blade is hardened, and great for aggressive fast cutting in hardwoods. The number of reverse teeth varies depending upon the tpi of the blade and is indicated below. The finer tpi have more reverse teeth than the coarser tpi blades. Twelve blades per package. Made in Germany.

830-7000#2/010 Reverse Teeth
830-7001#17 Reverse Teeth
830-7003#37 Reverse Teeth
830-7005#57 Reverse Teeth
830-7007#77 Reverse Teeth
830-7009#96 Reverse Teeth
830-7012#126 Reverse Teeth

Spiral Tooth Blades



These high quality 13cm long blades are extremely versatile and work extremely well in wood, plastic, and wallboard. The unique spiral tooth design is on all sides of the blade, enabling the blade to cut in all directions! Dimension is the diameter of the blade. Packs of twelve blades. Made in Germany.

830-5003#00.64mm
830-5013#10.68mm
830-5023#20.80mm
830-5033#30.88mm
830-5043#40.98mm
830-5053#51.05mm
830-5063#61.15mm

DE-STA-CO
Industrial Products Group

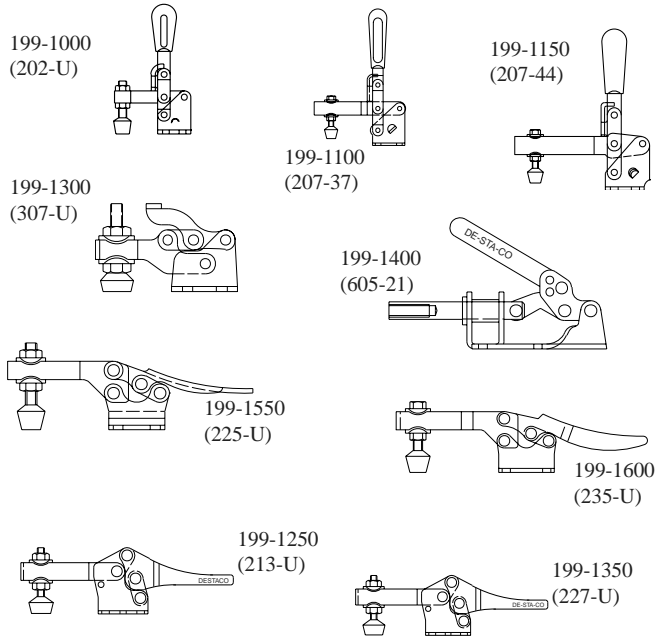

The hold-down clamps are easy to grab and activate quickly. Special versions of these include bar guides to provide extra lateral support and rigidity to the holddown bar at the front of the base (indicated with lateral support in the chart below). The low silhouette clamps are useful for tight applications, and the flat top of the handle can be used to easily attach a straight piece of material to "gang" a number of clamps for simultaneous action. Your imagination will find a tremendous number of applications for the straight-line clamp. All clamps include a spindle.

Specification A indicates handle movement in degrees for hold down clamps and spindle travel for straight line clamps. Specification B indicates the bar opening in degrees for hold down clamps and internal spindle thread size for straight line models.

Number	Description	Model	A	B	Capacity
199-1000	... Hold Down 1/4"-20 Spindle.....	202-U	64°	104°	200 lbs
199-1100	... Hold Down	207-37	62°	115°	375 lbs
199-1150	... Hold Down Long Arm	207-44	62°	115°	375 lbs
199-1300	... Hold Down Low	307-U	175°	92°	350 lbs
199-1400	... Straight Line Push & Pull	605-21	1.25"	7/16"-18	300 lbs
199-1550	... Hold Down	225-U	70°	90°	500 lbs
199-1600	... Hold Down	235-U	55°	90°	750 lbs
199-1250	... Hold- Down with lateral support ...	213U	60°	90°	150 lbs
199-1350	... Hold- Down with lateral support ...	227U	62°	92°	500 lbs

Router Mat

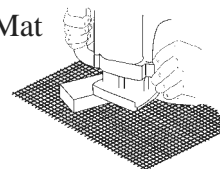

This friction router mat allows you to rout or sand small pieces of wood without clamps. Place the mat on the bench, the work on the mat, then use your router or sander. The special urethane formula router mat lets you get work done with no extra fuss or bother. Mat size is two by four feet.

825-6200 2' x 4' Mat

Slick Tape

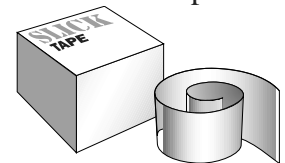

We call this slick tape, because it is really slick stuff! Your imagination will find a multitude of uses for this tape on fixtures, tool bases, drawer guides, etc. Both widths of slick tape are 1mm thick and 36" long.

825-1250 3" Slick Tape
825-1275 1/4" Slick Tape



TIMBER TOOLS - TRIMMERS VENEERING

Bark Spud

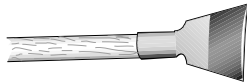

Made of high quality German steel and designed for stripping bark from logs for such things as timber frame construction or making posts. It features a hardened face side, an offset handle socket and a concave edge. Blade is 120mm wide, and the handle is approximately 48" in length.

- 598-1050 Bark Spud (without handle)
598-1000Bark Spud Handle ONLY

Log Pick with Twisted Handle



The handle is twisted to be comfortably aligned for safely gripping and carrying logs or other wood objects up to 7" in diameter. It is especially useful for moving wet, slippery logs. Made of steel with soft durable handle grip in Austria.

- 823-3000Log Pick

Timber Framing Chisel



Heavy duty beveled and non-beveled timber framing chisels by Robert Sorby. Originally designed for North American log cabin building. Overall length about eighteen to twenty inches.

- Beveled Chisel Size Handle Only
640-20161" 640-4102
640-20241 1/2" 640-4103
640-20322" 640-4103
Non-Beveled Chisel Size
640-21161"
640-21241 1/2"
640-21322"
640-4110Replacement Handle Only

Forged Drawknives

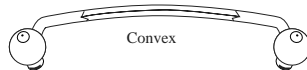
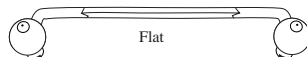

Nicely made drawknives are hot-forged and specially sharpened on felt wheels. Protective leather cases are included. The straight (flat) tool is available in three sizes and is useful on general work. The concave edge tool is good when you want to attack a slight hollow or when you want to attack very aggressively a problem area in a piece (a knot for example). The convex profile tool is good when you want to finish polish a curved area, example being a large rung, etc. Quality forged out of quality steel and well finished! Size indicated is the approximate length of the cutting edge, and the set is comprised of all three 150mm models. Made in France.

- 847-1050Flat 100mm Drawknife
847-1100Flat 150mm Drawknife
847-1200 Convex 150mm Drawknife
847-1300Concave 150mm Drawknife
847-1500Three 150mm Drawknives
847-1600Flat 250mm Drawknife

Drawknives

Here is a selection of three drawknives from Two Cherries available in either a curved or a straight edge model. Forged to same high standards as their other tools, each model has a blade that is 1 5/16" wide and 3/16" thick and two solid wooden handles that are about 4" long and perfectly positioned for the task at hand.



- 500-1320225mm Straight Edge



- 500-1350140mm Curved Edge



- 500-1370225 Curved Edge

Edge Trimmer

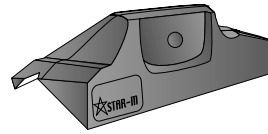

Designed to fit comfortably in the hand, this trimmer features two long lasting ceramic cutters, at either end, for both forward and backward usage. This tool trims excess edge material and leaves a chamfered profile. Approximately 3" in length.

- 776-1050 Ceramic Edge/ Chamfer

Double Edge Trimmer

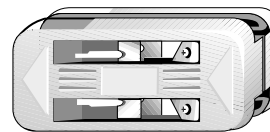

Simultaneously trim both sides of an edge-banded workpiece. It has hardened steel cutters and is adjustable within a range of 1/16" to 1/4".

- 825-6075Double Edge Trimmer

Veneer Cutter

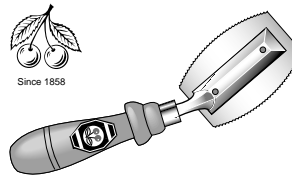

Veneer cutter with oval blade and off-set handle. Cutting veneer with a knife leaves a beveled edge on the veneer cut whereas this tool makes a ninety degree cut of your veneer allowing a perfect joining of veneer pieces. Made in Germany.

- 520-2200 Veneer Cutter
520-2210Replacement Blade
820-5100Sharpening File (Not Two Cherries)

Veneer Saw

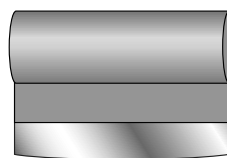

Traditional French veneer saw has a comfortable wooden handle and is gripped directly above the curved blade. This curved blade allows for a clean cut of your veneer. A quality tool made in France.

- 847-4000 Veneer Saw

Veneer Hammer

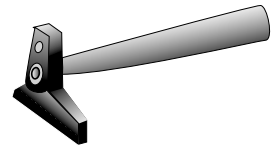

This is not a striking tool, but is used to smooth out the veneer surface. Made in Germany.

- 580-6100 Veneer Hammer

Laminate Rollers



Two styles of laminate rollers to choose from. The "J" style roller (illustrated) is more traditional in design. The new and improved press roller exerts pressure more in line with the grip.

- 825-4325 "J" Roller
825-4350Press Roller

"J" Roller

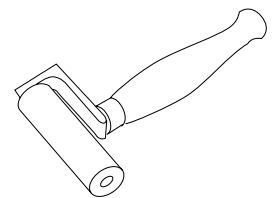

Designed for applying pressure on veneer and plastic laminates. Reaches into corners as roller has no axle projection on one end. Stainless roller never leaves marks on surfaces.

- 800-171040 mmSmall
800-172090mmLarge

Japanese Veneer Saw



Here is a handy saw that is the perfect tool for cutting veneer. Rounded blade will also facilitate starting a cut in the middle of thin material.

- 720-280072mm Blade



CLEANUP - MISCELLANEOUS

Counter Brush

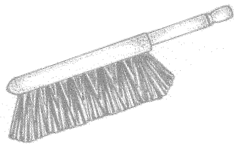

One hundred percent horse hair counter brush for the easiest clean-up of sawdust and shavings. Nine inch brush on a 13 3/4" nicely finished wood block. Helps make cleanup a more enjoyable job. Made in USA.

235-1000 Counter Brush

Giant Dust Pan

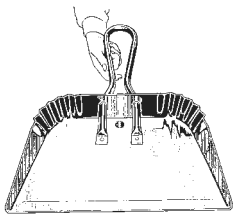

Pick up a shop full of saw dust and wood shavings in one scoop! The lip of this all aluminum pan sits flat against the floor for a no hands sweep up. The wide (17") opening of this larger dustpan makes for a fast clean up. Light weight and rust proof. Made in USA.

142-1000 Dust Pan

Household Dust Pan

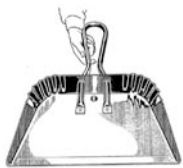

For smaller cleanup jobs, or as a general household dust pan, this light in weight. Great for household use with a 12" opening. Made in USA.

142-2000 Dust Pan

Insulation Cutter



This insulation cutter answers a demand for an easy to use, inexpensive, and effective tool for the cutting of fiberglass insulation, rock wool insulation, foam insulation, and other similar materials. The tool has an extremely sharp wavy edge, straight edge, and marking edge. The hard chrome plated SK2 high carbon steel blade is 6 3/4" long and .03" thick. The blade is attached to an attractively finished hardwood handle and includes a reusable storage pouch. Made in Japan.

740-5000 Insulation Cutter

Automatic Sewing Awl

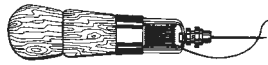

An excellent tool for sewing leather, canvas, and similar materials. The awl carries a spool of thread on the handle. Hollow handle holds extra curved needle and wrench. Directions included.

160-4000 Automatic Awl
160-4010 Extra Needles
160-4020 Reels of Thread

Sewing Needles

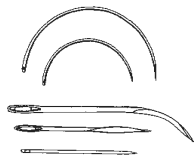

Assortment of professional type needles. Useful in every home! Two curved upholstery needles, one special bent needle, one awning or canvas needle, and one carpet needle.

160-1000 Sewing Needles

Beeswax

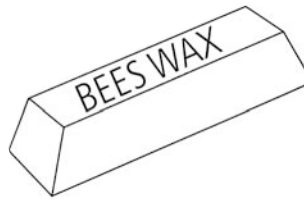

Beeswax has many uses in the home and in the shop. Helps lubricate wood to wood joints, dead centers of wood lathes, drive screws more easily. The uses are endless.

870-1000 1 Ounce Block
870-1010 1lb. Block

Universal Cutter

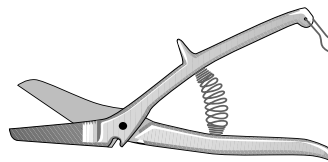

Light universal notched blade cutter and wire cutter. These cut copper, aluminum sheet, leather, carton, paper, and soft steel and soft steel wire (thin dimensions). They have a lovely "retro" form with a built-in hand stop. They have a "notch" above the pivot point which is specially hardened to do wire-cutting, like paper-clips etc. Striations in handle assure good grip. Hot forged. The lower jaw has mini-serrations to prevent the slippage of materials during cut. And though it is made of tool steel it can and does find good use in the kitchen as poultry shears. Just keep it dry after use. Keep one in the shop, one in the kitchen, and another with your garden tools. Made in France.

843-1000 Universal Cutter

Safety Sticks



Use this pair of sticks for control of your work. Counters the lifting tendency for front edge of workpiece. Allows you to place forward and sideway pressure all at once.

825-1100 Safety Sticks

Push Blocks

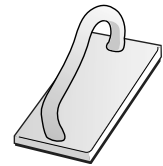

These push blocks should be in every shop that has a table saw, jointer, shaper, and other power tools. The rubber pad on the bottom of the block gives a firm grip on the work, while your hands are kept away from the danger area. Makes many operations safer than they might otherwise be without this tool

825-1025 Safety Push Blocks 3" x 6"
825-1050 Safety Push Blocks 2 1/4" x 16"

Push Stick

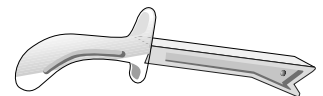

Push stick measures 11" long and has a comfortable grip handle. Keeps your fingers away from cutting edges.

825-1000 Push Stick

Rare Earth Magnets

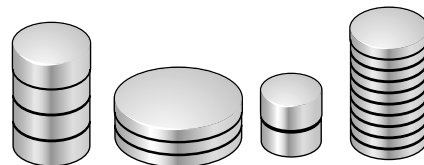

These are very strong magnets which can be used in a tremendous variety of applications in the shop and projects for the home. The only limitation is your imagination. Two applications include tool storage and "invisible" catches.

825-4775 10 pieces..... Magnets-10mm x 5mm
825-4800 10 pieces..... Magnets-8mm x 5mm
825-4825 10 pieces..... Magnets-10mm x 3mm
825-4850 10 pieces..... Magnets-9.5mm x 1.5mm
825-4875 10 pieces..... Magnets-6mm x 3mm
825-4900 6 pieces..... Magnets-24.5 x 3mm
825-4925 6 pieces..... Magnets-19mm x 3mm

Millimeters to Inches

Millimeters	Inches
1	0.039
2	0.078
3	0.118
4	0.157
5	0.196
6	0.236
7	0.275
8	0.314
9	0.353
10	0.393
20	0.787
30	1.181

40	1.574
50	1.968
60	2.362

Inches to Millimeters

Inch	Millimeters
1/32	0.8
1/16	1.6
1/8	3.2
3/16	4.8
1/4	6.4
5/16	7.9
3/8	9.5
7/16	11.1
1/2	12.7



FINISHING

Painters' Tools

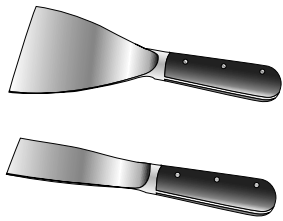

These highest quality painters' tools are made of special spring tempered blades (Sheffield steel) and are the finest tools for craftsman and hobbyist alike.

- 615-2110 1" Stiff Blade
615-2130 2" Stiff Blade
615-2150 3" Stiff Blade

Glue Scraper

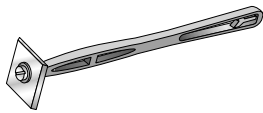

Heavy duty tool designed to make life just a little easier. Blade is high quality steel. Cleaning up a glue joint will not be a problem again.

- 580-2175 Glue Scraper
580-2176 Blade Only

Bees Wax Polish



Cream polish that is delightful and safe to use. Architectural Digest said, "There's a polish made by a beekeeper in British Columbia . . . this particular formula is outstanding".

- 870-2002 Bees Wax Polish 2oz
870-2008 Bees Wax Polish 7oz

Salad Bowl Finish



Oil and wax finish for salad and fruit bowls, butcher's blocks and cutting boards. Two sizes available.

- 870-3002 Salad Bowl Finish 2oz
870-3008 Salad Bowl Finish 8oz

Shavehook Set

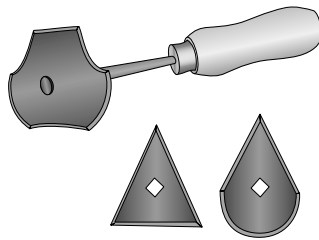

This shavehook, or moulding scraper, is ideal for a variety of tasks, including touching-up moulding shapes and restoration projects.

- 620-1450 Shavehook Set

Triangular Shavehook

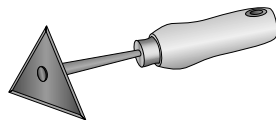

Triangular shavehook can be used for heavy duty scraping, but small and light enough that you will find many other uses for it as well.

- 620-1420 Triangular

Beeswax Barrier Cream



Developed for people whose work is potentially harmful to their hands. It is waterproof, and protects against other sensitizers such as oil and dirt.

- 870-4000 Beeswax Barrier Cream 7oz
870-4200 Beeswax Barrier Cream 2oz

Double Curved Varnish and Paint Brushes

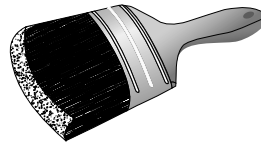

These high quality hand-made brushes are ideal for applying varnish and other oil based finishes. They feature bristles made of 100% pig silk (hog bristle) and they are completely filled, without any filler bristles or stuffer.

- 839-1125 25mm Brush
839-1150 50mm Brush
839-1175 80mm Brush



Constructed in a similar manner to the other brushes except these are made for water-based products, such as, Latex paint. To facilitate paint flow, these are 50% pig silk and 50% artificial bristles.

- 839-1525 25mm Brush
839-1550 50mm Brush
839-1575 80mm Brush

String Wrapped Glue Brushes



Made to exacting age-old standards by a renowned European company, these hand assembled glue brushes can be used to apply hide (animal or fish) glue and standard shop glues.

- 839-4025 Ref. #4
839-4050 Ref. #10
839-4075 Ref. #3 Plus

Cutting in Brushes



High quality brushes designed for oil based materials. Made of 100% pig silk (hog bristle) and featuring turned wood handles and copper ferrules.

- 839-2025 15mm Diameter
839-2050 19mm Diameter
839-2075 23mm Diameter



High quality hand-made cutting in brushes designed for latex based materials. To facilitate paint flow, these are 50% pig silk and 50% artificial bristles.

- 839-3025 15mm Diameter
839-3050 19mm Diameter
839-3075 23mm Diameter

Paint Removal Brushes

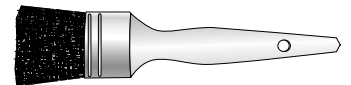

Made for delicate finish work and features a wooden handle and brush with bronze filling. It is approximately 1/4" (30mm) in width.

- 839-4525 30mm

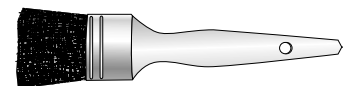

Made for vigorous work and features a wooden handle and brush with stainless filling. It is approximately 1/2" (40mm) in width.

- 839-4550 40mm



MALLETS - TACK LIFTERS - HAMMERS

Carpenters' Mallet

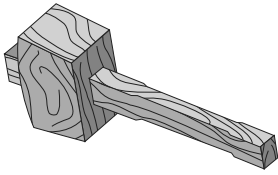

Carpenters' mallets of selected beechwood. Mortised heads and tapered handles of non-twist grip design, securely fitted. Made in England.

615-1210 Small
615-1220 Large

Warrington Hammer

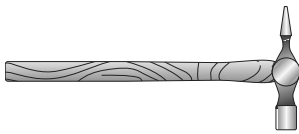

Cross-pein on one side lets you start small brads without injury to fingers. This traditional cabinetmakers hammer also makes it easy to pound a nail close to a vertical piece or in a tight corner. Made in Germany.

590-1000 4 oz.
590-1100 8 oz.
590-1200 10 oz.

Magnetic Brad Driver

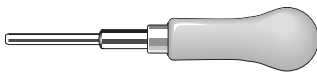

This magnetic brad driver starts, drives, and countersinks finishing nails, headless brads, and pins. Beechwood handle and brass barrel. Magnet holds the brad in the barrel while you position the tool. This is a must have for your shop, and you will be reaching for it more often than you might think!

620-0560 Brad Driver

"Wood is Good" Mallet

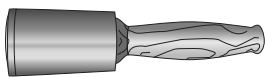

The "Wood is Good" mallet maintains the same hand grip on the wooden handle throughout the range of sizes -- twelve ounces through thirty ounces. A long lasting tool that does not harm the chisel handle, and is easy on the carvers hand and arm during extensive carving sessions. This is thanks to the synthetic striking surface that will absorb shock before it can get to your arm, and yet transmits the striking force to the tool. USA

170-1012 12 oz
170-1018 18 oz
170-1020 20 oz
170-1030 30 oz

Cat's Paw

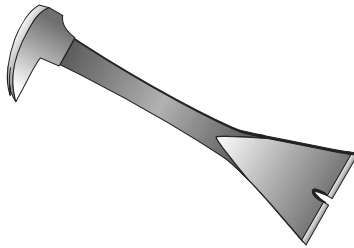

Three very useful cats paw type bars with a wide prying edge. Perfect for restoration of furniture or homes where one must carefully remove pieces that need to be treated with extreme care. Made in Japan.

750-5075 150 mm
750-5100 200 mm
750-5125 250 mm

Mighty Bar

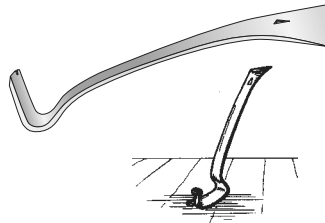

This is a very small bar, but when you need something of this size, it is indeed "mighty". This thin, yet strong tool, will be able to fit into the smallest opening to begin prying. Overall length of the tool is 190mm. Curved end is less pronounced than shown in illustration. Made in Japan.

745-4550 Mighty Bar

Carpenters Hammer

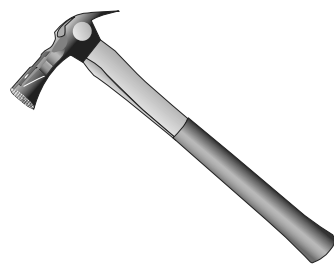

This is a 20 oz. hammer which incorporates a uniquely designed magnetic nail holder. The nail is held in a groove atop the hammer's head thus permitting the user to hold the workpiece material with a free hand. The groove in the hammer head is slotted for both long and shorter nails, that is, nails from 2" up to 4" in length. Additionally, for better and more efficient leveraging while pulling out nails, the hammer features a shorter claw. Made with a rubber grip on a fiberglass handle. Made in Japan.

775-3060 20" Fiberglass Handle

3 in 1 Nail Setter Bar

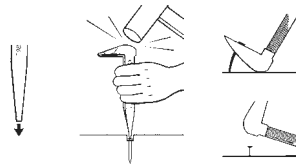

This handy bar is very similar to our "Cat's Paw" tool -- it can be used to pull nails, and as a lever for prying. In addition, the end of this versatile tool has a nail setting point. This feature will be invaluable for those doing remodeling work, in particular. Overall length of the tool is 160mm. Made in Japan.

745-5050 Nail Setter Bar

Tack Lifter

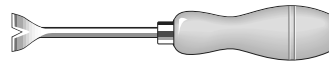

High quality tack lifter with clear finished beechwood handle. Great for re-upholstery work, or wherever small nails must be removed. Made in England

605-5200 Tack Lifter

Hollow Screw Extractor



Turned counterclockwise in an electric drill, this tool makes easy work of removing broken screws from wood, while leaving a clean hole that can be filled with a dowel or plug. Use the 1/4" model for screws up to #8 and the 5/16" model for #10 screws and larger. Size refers to the finished hole size.

800-3004 1/4"
800-3005 5/16"
800-3006 3/8"

Nail Setter



If you have ever tried to nail in a tight spot or in a place just a little too far to reach, this is the answer to those problems. Sturdily built tool has a magnetized rod that moves in the surrounding cylinder. Pull the rod back and place a nail in the cylinder then hit the rod with a hammer. Nailing has never been this easy before. Made in Japan.

775-4200 200 mm
775-4400 400 mm

Cat's Paw



The cat's paw is a small crowbar type tool for small work or tight places. This complete range of sizes is of the finest quality, and have very nicely finished ends to help in accomplishing delicate work. If you have not tried one of these handy tools before, try only one and you will likely see a need to own the entire range. Made in Japan.

Number	Approximate Length
745-2010	160mm
745-2020	210mm
745-2040	250mm
745-2060	280mm
745-2070	300mm

Carpenter Hammers

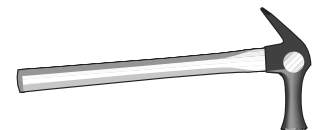

Dogyu Brand carpenter hammer from Japan is a uniquely balanced quality tool -- available in both smooth and waffle face. Give it a try, and you will not want to go back to your old style hammer. Magnetic version will hold a nail in a starting position, and with only one swing the nail is ready to drive home in the usual way!

775-2050 Waffle Face 16 oz.
775-3050 Magnetic Waffle Face 16 oz.
770-2000 Smooth Face 16 oz.





INDEX

2-Cut Chisel 1
90 Degree Mortice Chisel 2

A

Adjustable Bevel 27
Adjustable Bits 15
Adze 9, 37
Aluminum T-Track 42
Angle Divisor 24
Angle Jig 28
Angle Master 27
Angle Transfer Bevel 24
Apron 9, 38
Arkansas Stones 30
Auger Bits 17
Awl 10, 26, 37

B

Band Clamp 41
Baseball Cap 9
Bearing Lube 44
Bearings 43
Bees Wax 46
Bees Wax Polish 47
Bench Dogs 17, 28
Bench Holdfast 17
Bench Pup 28
Bench Stop 17
Bevel Edge Chisels 1
Bevel Gauge 24, 27
Blade Guard 40
Bladecote 44
Block Planes 33, 35
Brace 17
Brad Driver 48
Brad Point Drills 15
Brad Set 41
Brass Back Dovetail Saws 10
Brass Caliper 24, 27
Brass Sleeves 23
Breast Drills 17
Bronze Mallets 9
Brushes 47
Bullnose Rebate Plane 35
Burnisher 10, 28, 31, 34
Butt Chisels 2

C

Cabinet Rasps 18
Cabinet Scraper 10, 33
Caliper 23, 27
Caliper - Brass 24
Camillia Oil 37
Carbide Drill Bits 15
Carcass Saw 27
Carver's Adze 37
Carver's Hook 9
Carver's Mallet 38
Carvers Screw 9
Carvers Spoon 37
Carving Mallet 9, 38
Carving Set 37
Carving Stand 38
Carving Tool Sets 6-7
Carving Tools 3, 8, 37-38
Cats Paw 48
Center Finder 24, 27
Center Marker 29
Chainsaw Files 18
Checkering Tools 39
Chip Carving Knives 8
Chisel Handles 2
Chisel Rolls 37

Chisel Set in Leather Roll 1
Chisel Set in Wooden Box 1
Chisel Sets 1
Chisels 1, 37
Circle Cutter 25
Circular Plane 33
Clipo Plane Parts 34
Clock Movement Bit 15
Combination Square 24
Combination Square Set 24
Compasses 23
Contour Gauge 25
Coping Saw 40
Cork Sanding Block 18
Corner Chisel 42
Cornering Tool 28
Counter Brush 46
Countersink - Hand 17
Countersink Parts 16
Countersinks - Fuller 16
Countersinks - Fuller 16
Crown Molding Book 25
Curved Chisels 2
Curved Gouges 2
Cutterhead Adjuster 43
Cutting Gauge 26

D

Dado Shims 29
Dividers 23
Dockyard Tools 38
Dogs 17
Dovetail Gauge 27
Dovetail Saw 10, 27
Dowel Former 43
Drawknives 9, 45
Drill & Dowel Gauge 27
Drill Bits 15
Drill Guide 43
Dust Pan 46

E

Egg Beater Type Drills 17
Elite Benches 12
Engineer's Square 24

F

Feather Board 42
File Handles 18
Files 18
Finger Guard 38
Flexible Curve 25
Flush Cut Saw 36
Forstner Bits - Inch Sizes 15
Forstner Bits - Metric Sizes 15
Fretsaw 40
Fretsaw Blades 40, 44

G

Gimlets 17
Glidecote 44
Gloves 38
Glue Bottle 39
Glue Scraper 47
Glue Syringes 39
Gouges 2
Grinding Jig 28

H

Hammer 48
Hand Countersink 17
Hand Cream 47
Hand Drills 17
Handles, Chisel 2
Hock Tools 32

Hold-Down Clamps 44
Honing Guide 27-28, 31-32
Honing Oil 30
Hooked Rule 25
HSS Turning Tools 20

I-K

Inshave 9
Inside Calipers 23
Insulation Cutter 46
Japanese Chisels 37
Japanese Saw File 18
Japanese Saws 36
Jenning Auger Bits 17
Jewelers Blades 40
Junior Saw 40
Keller Dovetail System 11
Kevlar Gloves 38
Key Ring Carving Tool 9
Keyhole Saw 36
Knife - Violin 32
Knives, Chip Carving 8
Kunz Planes 33

L-M

Leather Scraper Holder 10
Level 26
Lubricants - Woodworking 44
Magnets 46
Magnifying Hood 38
Mallet 9, 38, 48
Marking Gauge 26
Marking Knife 26, 32
Metric Drill Bits 15
Micro Carving Tools 8
Miniature Carving Tools 38
Miniature Planes 34
Miniature Try Square 26
Miter Box 40
Miter Cutting Hand Shear 41
Miter Trimmer 41
Miter Vise 41
Mite-R-Gage 25
Mitre Clamps 41
Mitre Square 24
Mortise Chisel 2
Mortise Gauge 26
Multi Plane 35

N

Nail Setter (Pea Shooter) 48
Needle Files 19
Needle Kit 46
Needle Rasps 19
Nordic Plus Benches 13

O-R

Oire Nomi Chisel 37
Outside Calipers 23
Paint Brushes 47
Pantograph 42
Pear Shaped Handle Carving Tools 7
Pencils 29
Pinch Dogs 39
Plane Irons 32
Planes 33, 35
Plough Plane 35
Plug Cutters 15-16, 29
Pocket Plane 33
Problem Solver Kit 2
Protractor 25
Push Stick 46
Radius Plane 34
Rasps 18



INDEX

Rasps - Needle	19	Slick Tape.....	44	True Angle.....	25
Ratchet Screwdrivers	17	Sliding Bevel - Metal.....	26	Try & Setup Gauge (Brass).....	27
Rebate Plane.....	33-34	Sliding Bevel - Rosewood	26	Try Square - Rosewood	26
Resurfacing Stone	31	Slip Stones	30	Turners Burnisher	28
Riffler Rasps.....	19	Sliver Gripper.....	40	Turner's Caliper	23
Rosewood Layout Tools.....	26	Small Carving Tools.....	6-8	Turner's Sanding Pack	23
Router Bushings.....	42	Smart Vise.....	14	Turning Tool Handle.....	23
Router Pad.....	44	Snug Plug Cutter.....	29	Turning Tools.....	20
Rulers	24-25	Spiral Blades	44	Tweezers.....	40
Ruler - Adhesive	25	Spokeshaves.....	33-35	Two Cherries Tools	1
S		Squares - Metal	24	U-V	
Saddle Square.....	29	Stair Case Rasp	19	Universal Bits.....	15
Salad Bowl Finish.....	47	Stern Tools	15	Veneer Cutter	10
Sander Rasps.....	19	Stones.....	30-31	Veneer Cutter Sharpening File	10
Sanding Block.....	18	Stop Collars.....	16	Veneer Hammer	45
Sanding Tools.....	18	Straightedge	29	Veneer Saw.....	45
Saw Blades.....	40	Strop.....	31	Veritas Tools.....	27-29
Saw Set.....	18	Swan Neck Chisel.....	2	Vise	17
Saw Step Gauge	42	T		Vix Bits	16
Saws	36	Tack Lifter.....	48	W-Z	
Scorp	9	Taper Drills	16	Warrington Hammer	48
Scraper Plane	33	Tapering Jig.....	42	Water Stones	31
Screw Extractor.....	48	Tenon Cutter.....	29	Wheel Dresser.....	31
Sculpting Adze.....	37	Tenon Mills	15	Whittling Kits.....	38
Self-centering Drill Bits.....	16	Thickness Gauge.....	24	Wonder Dog	28
Sharpener - Tool.....	31	Threadbox	42	Wood Burner.....	39
Sharpening DVD.....	32	Thumb Guard	38	Wood Carving Set	37
Sharpening Stones.....	30-31	Timber Chisels	45	Wood Is Good Mallets	38
Shavehooks	47	Timber Tools	45	Wood Ruler	24
Shelf Pin Drill Jig.....	43	Tool Roll	9, 38	Woodworking Vise.....	17
Shoulder Plane	34	Tool Setup.....	42	Work Benches	12
Side Rebate Plane	33	Tool Sharpener	31		
Sjöbergs Benches.....	12	Trammel Points	24		
Skew Chisels.....	2	Transfer Scribe.....	29		

Notes

