

BOSTITCH®



Upholstery | Furniture Framing
Tools & Fasteners

BOSTITCH - understanding your industry from the inside...

Since 1895, **BOSTITCH** has been designing and manufacturing tools and fasteners for a wide variety of applications and industries.

With over 500 million fasteners made every day, **BOSTITCH** is one of the largest manufacturers of nailing & stapling tools and fasteners in the world.

This brochure represents our bespoke range of professional fixings solutions for the furniture, bedding and upholstery businesses, and reflects our continued innovation resulting in many developments for familiar tools.

To make sure our tools match our reputation, we go to extremes to ensure that every tool bearing our name is more than capable of providing years of safe, reliable and trouble free service.

The reassurance of global leadership

BOSTITCH is part of the **Stanley Black & Decker** organisation, the global leader in tool manufacture across a wide range of industries.

No company on earth has a stronger or more compelling history of delivering the hardworking, innovative, powerful tools that help professionals around the world keep working.

- **\$11 billion value on worldwide markets**
- **Global recognition with an outstanding portfolio of global brands**
- **Recognised as among the top 10 global innovators**
- **No.1 for worldwide tool manufacture with outstanding quality control**

Committed to Standards & Safety

Your workforce is your most valuable resource, so as well as developing ergonomically designed tools that are comfortable to use, we aim for the highest safety standards.



All our tools are fully compliant with stringent European health & safety regulations and we offer comprehensive health & safety training courses, so that you know your staff are using the tools safely.

To find out how your business can benefit from BOSTITCH expertise, call our sales team or visit the website, www.bostitch.co.uk.



CONTENTS

Bed Frames

Medium & Heavy Duty Stapling/
Coilnailing/ Corner Jointing

4-8



Sofa Frames

Medium & Heavy Duty
Stapling/ Coil Nailing/
Corner Jointing

4-8

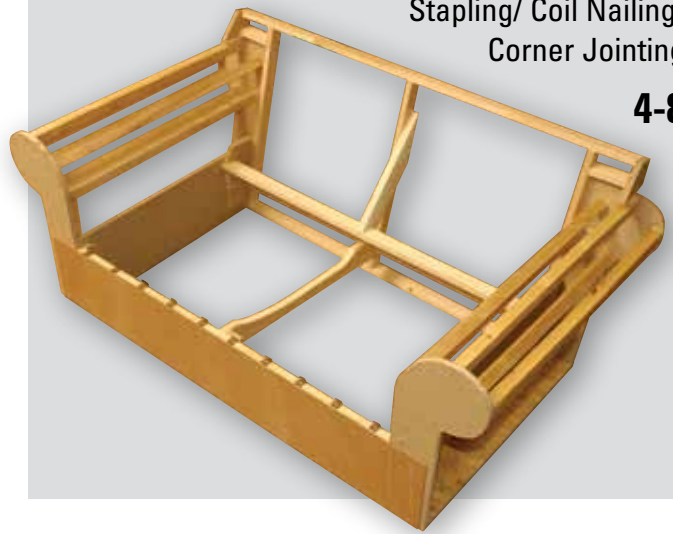

Special Applications

9



Padding & Covering

Pliers

12-13



Mattress Assembly

10-11



Upholstery

Upholstery Staplers

14-17



Automated Solutions

Bespoke Machines

Seat rails

18-19



BED & SOFA FRAMES



BOSTITCH- for Bed & Sofa Frame Construction

Our comprehensive framing range covers everything you need. With tools that drive staples from 12 to 64mm length as well as corrugated fasteners and coil nails, our products represent the best you can buy.

With a choice of magazine capacities, fastener types and driving power, you can tailor your tools and fasteners to your business.





The versatile range for dependable framing

Our tool and fastener range covers all types of furniture frames for chairs, beds, sofas and suites. With so many options to choose from, we're confident that we can supply your needs, whatever the application.

Beginning with your choice of staple, simply select the corresponding tools to make your selection. Individual tools

incorporate many production specific and operator friendly features, giving you a range of options perfectly suited to your workforce and manufacturing environment.

If you can't find what you're looking for, please contact us. As a global company, we have resources to accommodate unusual requirements.

Fastener Family	SX Series	SL Series	S5/100 Series	S4/16NC Series
				
Compatible Tools	SB156SX-1	SB156SL-1	538S5-1	538S4-1
			650S5-1	650S4-1
			651S5	-
			750S5-1	750S4-1
			765S5-1E	765S4-1E

Tool Noise & Vibration Data

Tool	Noise			Vibration / Uncertainty m/s ²
	LPA 1sd	LWA 1sd	LPA 1s,1m	
SB156SL-1 / SB156SX-1	72.1	80.4	67.4	3.77 / 1.89
538S4-1 / 538S5-1	92.9	97.6	84.6	2.50 / 1.25
650S4-1 / 650S5-1	76.3	82.7	69.7	3.22 / 1.61
651S5	93.6	100.2	93.6	2.63 / 1.32
750S4-1 / 750S5-1	76.5	84.0	71.0	3.88 / 1.94
765S4-1E / 765S5-1E	84.1	93.4	80.4	2.80 / 1.40
CF15-1-E	93.6	99.6	86.6	4.29 / 2.15

BED & SOFA FRAMES

Medium Duty Staplers SB156SX-1 / SB156SL-1

This lightweight medium duty stapler is designed for frame and trim applications. Uses SL / 92 and SX / 90 series staples up to 40mm length. Bottom access magazine for convenient reloading.

SX/ 90 Series	SL/ 92 Series



Tool Features

- AI** Aluminium housing- durable and lightweight for all day use
- DIAL-A** Dial-A-Depth- for easy depth of drive adjustments
- CT** Contact trip trigger- for safer operation
- Bottom loading stapler-** for quick reloading
- 360°** Adjustable exhaust- for comfort and safety
- Easy view magazine-** for convenient reloading

Heavy Duty Staplers 538S5-1 / 538S4-1

Features an adjustable power control for variable fastener penetration. Rear exhaust for comfort. Two models available for S4/16NC and S5/100 staples.

S5/100 Series	S4/16NC Series



Tool Features

- Compact nose design-** for accurate placement
- DIAL-A** Dial-A-Depth- for easy depth of drive adjustments
- Anti slip bumpers-** helps prevent damage
- Adjustable power control-** ensures controlled fastener penetration
- CT** Contact trip trigger- for safer operation
- ANTI-JAM** Anti-jam nose- for smoother workflow

BED & SOFA FRAMES

Heavy Duty Staplers 650S5-1/ 650S4-1

Features Dial-a-Depth power control for variable fastener penetration and 360° exhaust for a cleaner working environment. Two models available for S4/16NC and S5/100 staples.

S5/100 Series	S4/16NC Series
11mm	12.5mm
25-50mm	25-50mm



2.0kg



Tool Features

- AI Aluminium housing**- durable and lightweight for all day use
- DIAL-A**-Dial-A-Depth- for easy depth of drive adjustments
- 360°** Adjustable exhaust- for comfort and safety
- CT** Contact trip trigger- for safer operation
- ANTI-JAM** Anti-jam magazine- for faster throughput
- Anti slip bumpers**- helps prevent damage



Heavy Duty Stapler 651S5

Featuring a selectable trigger system and depth adjustment for maximum flexibility and control, the 651S5 provides high-end driving power from 25-50mm.

S5/100 Series
11mm
25-50mm



1.9kg



Tool Features



- AI Aluminium housing**- durable and lightweight for all day use
- DIAL-A**-Dial-A-Depth- for easy depth of drive adjustments
- Utility hook**- for convenient tool storage
- CT ST** Selectable trigger system- switches between sequential and contact trip instantly
- Rubber comfort grip**- comfortable to use



BED & SOFA FRAMES

Heavy Duty Staplers 750S5-1/ 750S4-1

50% more driving power than the 650 models, with compact nose and Dial-a-Depth adjustment, this tool is ideally suited to heavy duty framing applications. Two models available for S5/100 & S4/16NC staples.

S5/100 Series	S4/16NC Series
 <p>11mm</p> <p>25-50mm</p>	 <p>12.5mm</p> <p>25-50mm</p>



2.4kg





Tool Features

- AI** Aluminium housing- durable and lightweight for all day use
- DIAL-A** Dial-A-Depth- for easy depth of drive adjustments
- 360°** Adjustable exhaust- for comfort and safety
- CT** Contact trip trigger- for safer operation
- Anti slip** bumpers- helps prevent damage
- Rubber** comfort grip- comfortable to use

Heavy Duty Stapler 765S5-1E / 765S4-1E

These tools have a rugged industrial design and increased power, making them capable of driving lengths up to 64mm for both S5/100 (765S5-1E) and S4/16NC (765S4-1E) staples.

S5/100 Series	S4/16NC Series
 <p>11mm</p> <p>38-64mm</p>	 <p>12.5mm</p> <p>38-64mm</p>



2.4kg



Tool Features

- AI** Aluminium housing- durable and lightweight for all day use
- Compact** nose design- for easy placement
- CT** Contact trip trigger- for safer operation
- Rubber** comfort grip- comfortable to use

BED & SOFA FRAMES

Corner Jointing Tool CF15-1-E

Lateral grip from the corrugated fastener is ideal for the bracing of frame joints or mitres. The fastener can be used to repair or reinforce splits along the grain.

Corrugated Fasteners

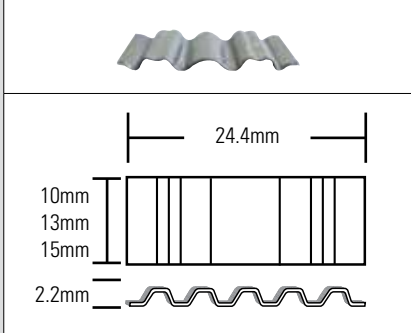

Tool Features



Push Button Magazine Adjustment-
for easy fastener changes



Contact trip trigger-
for safer operation



Mg **Magnesium body-**
lightweight and durable



Anti slip bumpers-
helps prevent damage



360° **Adjustable exhaust-**
for comfort and safety



SPECIAL APPLICATIONS

Our close relationship to real working environments gives us a unique insight into individual production methods and has led to the development of specialised tools for very specific applications, all designed with the characteristic BOSTITCH commitment to rugged reliability.

Stapler BCAR1B-495-92L

Purpose designed tool for attaching spring assembly to divan bases. Long nose format for convenient operation.



BCS 31 Series Staples

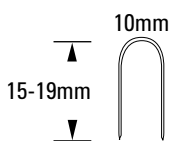

Tool Noise & Vibration Data

Noise			Vibration m/s ²
LPA 1sd	LWA 1sd	LPA 1s,1m	
83.7	93.0	80.0	<2.5

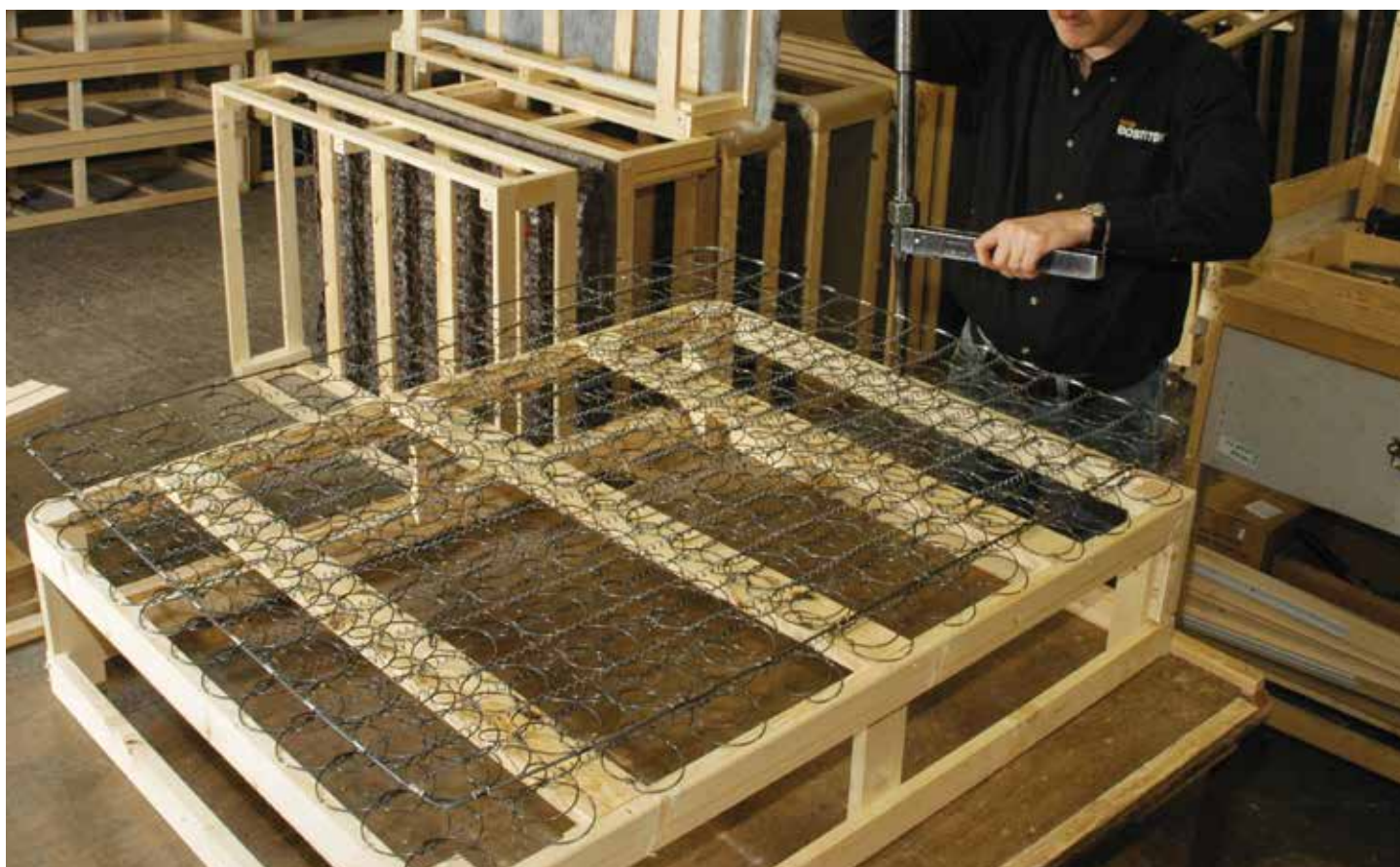

MATTRESS ASSEMBLY *Border Wires & Clinching*

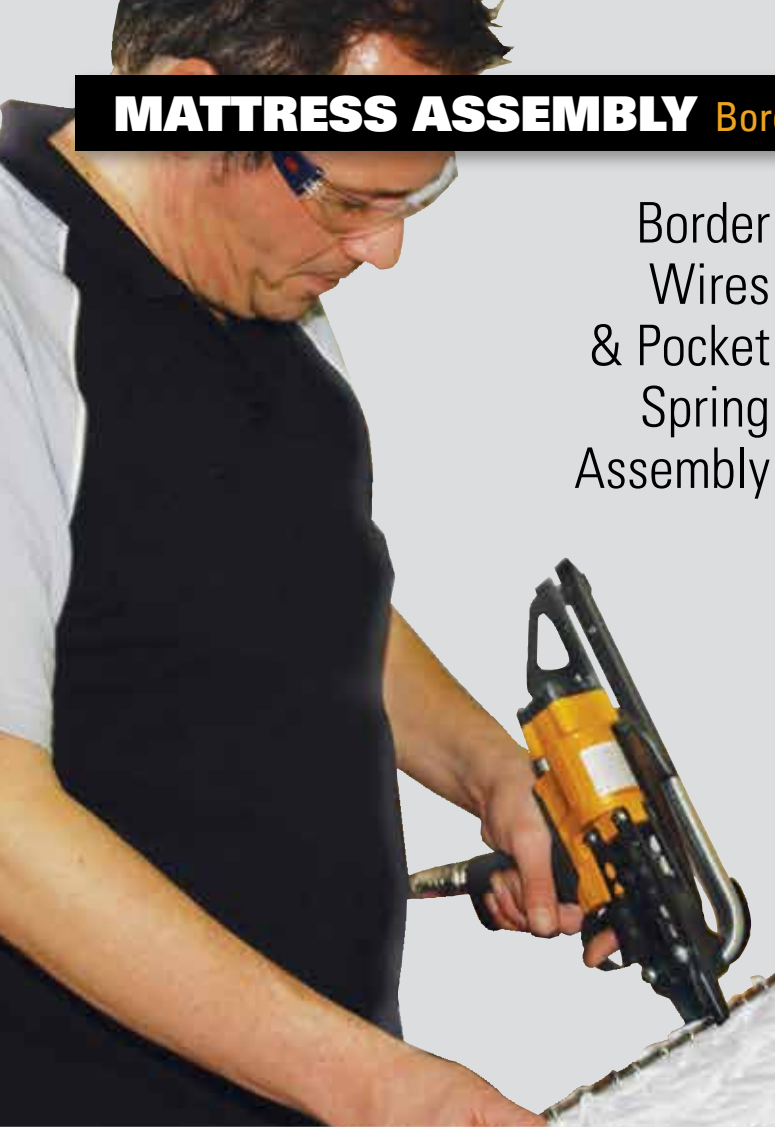

Border Wires & Pocket Spring Assembly

The **BOSTITCH** range of ringers and fasteners provide a flexible approach to new materials and methods in mattress construction.

From budget construction through to pocket sprung and flat border wire fastening, our tools are comfortable, durable and hard working. C or D ring formats offer a choice of closure profiles to suit your preference. For dependable clinching and reliable service, you can't beat **BOSTITCH**.

Our tools enable maximum productivity from your workforce and our fastener give the best performance for your applications.



Ring Formats & Applications

D-Ring

Round border wire to spring



C-Ring

Round border wire to pocket spring



C-Ring

Flat border wire to pocket spring



Tool Noise & Vibration Data

Tool	Noise			Vibration m/s ²
	LPA 1sd	LWA 1sd	LPA 1s,1m	
SC761 / SC743 SC7C / SC7E	86.38	91.47	78.47	<2.5
TR201 / TR203 / TR315	81.62	88.14	75.14	<2.5

MATTRESS ASSEMBLY Border Wires & Clinching





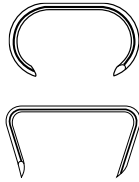













C Ring D Ring

Fastener & Tool sizing



To select the right tool for your application:

1. Measure the total distance across the wires when put together- making an allowance for either 'tight' or 'loose' finished clinch.
2. From the table below, find the ring with a minimum or maximum closure closest to your need.
3. Select whether you require blunt (B suffix) or sharp (P suffix) rings.

TOOL	SC761	SC743	SC7C	SC7E	TR201, TR203 TR315
Tool Weight 	2.9kg	2.8kg	2.9kg	2.9kg	1.4 / 1.6 / 1.6kg
Ring Open Size 	12.5mm 	19mm 	19mm 	19mm 	19mm 
Ring Closure Size Min. 	5.6mm 	8.7mm 	8.7mm 	10.7mm 	9.5mm 
Ring Closure Size Max. 	4.8mm 	4.8mm 	4.8mm 	7.9mm 	6.3mm 
Rings Part No.	RING 516	RING 16	RING 15	RING 15	RING SR15



C Ringers SC7 Series

The SC7 series C ringers are the choice for mattress, cage and other wire to wire applications. Complete with air spring return, they're fast and easy to use. Trigger fire provides the ultimate in operator control.



Tool Features

AI Aluminium housing- durable and lightweight for all day use

AIR Air return mechanism

TF Trigger Fire

D Ringers TR Series

Aluminium bodied D ringer with a choice of spring or air return for fast and efficient fastening.

Tool Features

AI Aluminium housing- durable and lightweight for all day use

AIR Air return mechanism TR315 Model

CR Spring return mechanism TR201 and TR203 Models

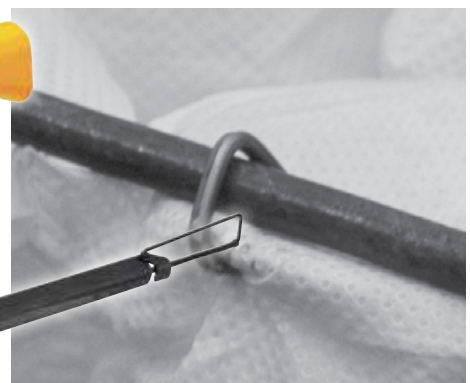

PADDING & COVERING

Pliers

Felt, foam or padding, a secure fixing is essential to the integrity of a Mattress or Sprung Base.

Ergonomic design coupled with a range of jaw options make Bostitch Stapling Pliers key to efficient manufacture. Featuring a lightweight aluminium bodies and balanced design, our pliers are comfortable to use all day long.

Two models are available with a choice of 0.5x1.2mm (P88SJ-E) or 0.6x1.6mm (P110SJ-E) wire diameters.

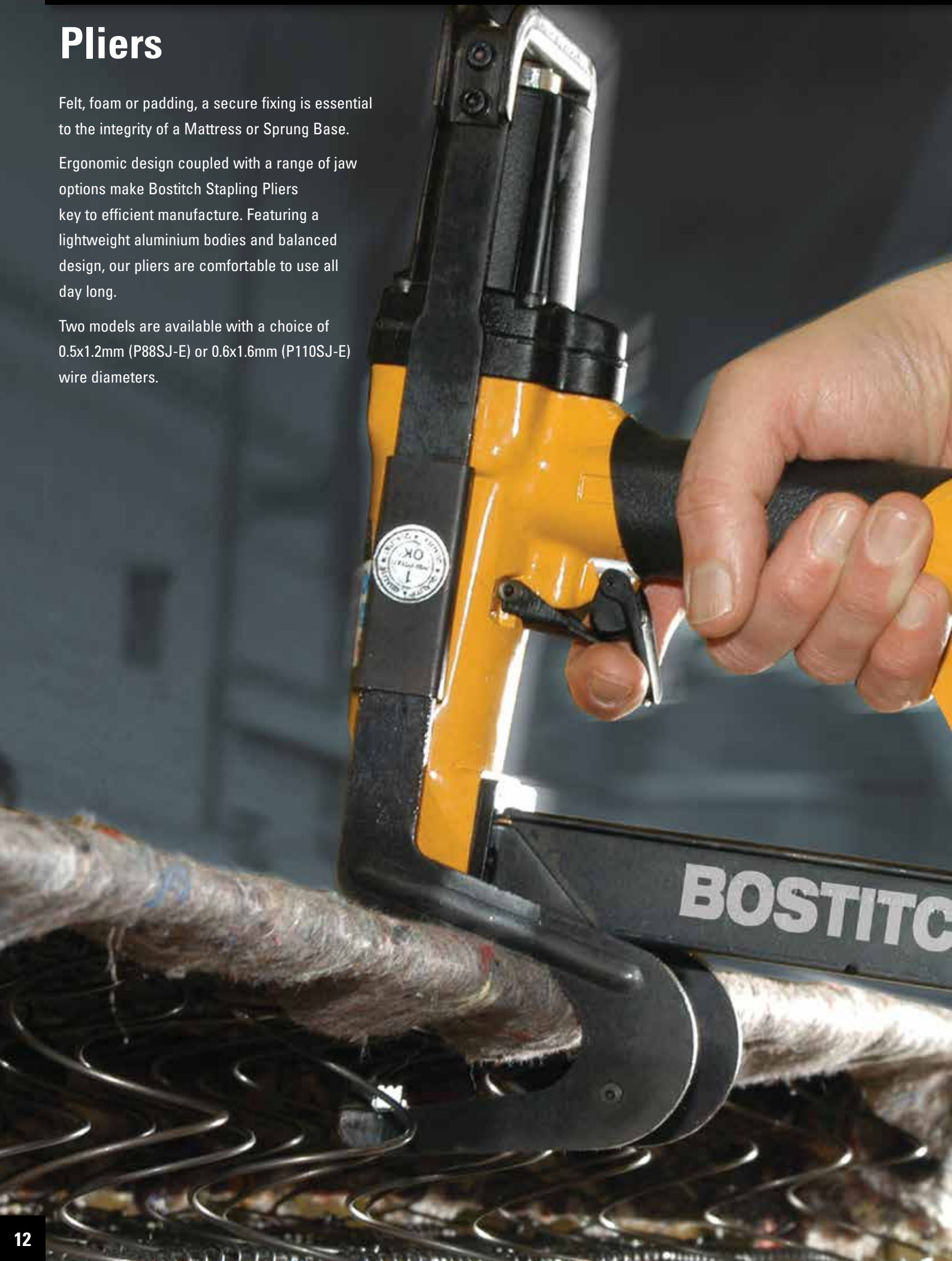

PADDING & COVERING

88 Series
Bedding Plier

P88SJ-E

110 Series
Bedding Plier

P110SJ-E

88 Series Staples

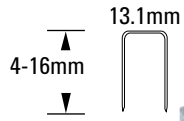

110 Series Staples

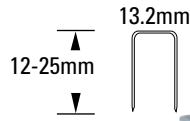

Tool Noise & Vibration Data

Tool	Noise			Vibration / Uncertainty m/s ²
	LPA 1sd	LWA 1sd	LPA 1s,1m	
P88SJ-E	84.4	90.7	77.7	2.5 / 1.25
P110SJ-E	84.4	90.7	77.7	2.5 / 1.25



Tool Features



Aluminium housing-
durable and lightweight
for all day use



Trigger Fire



Square Jaw Design

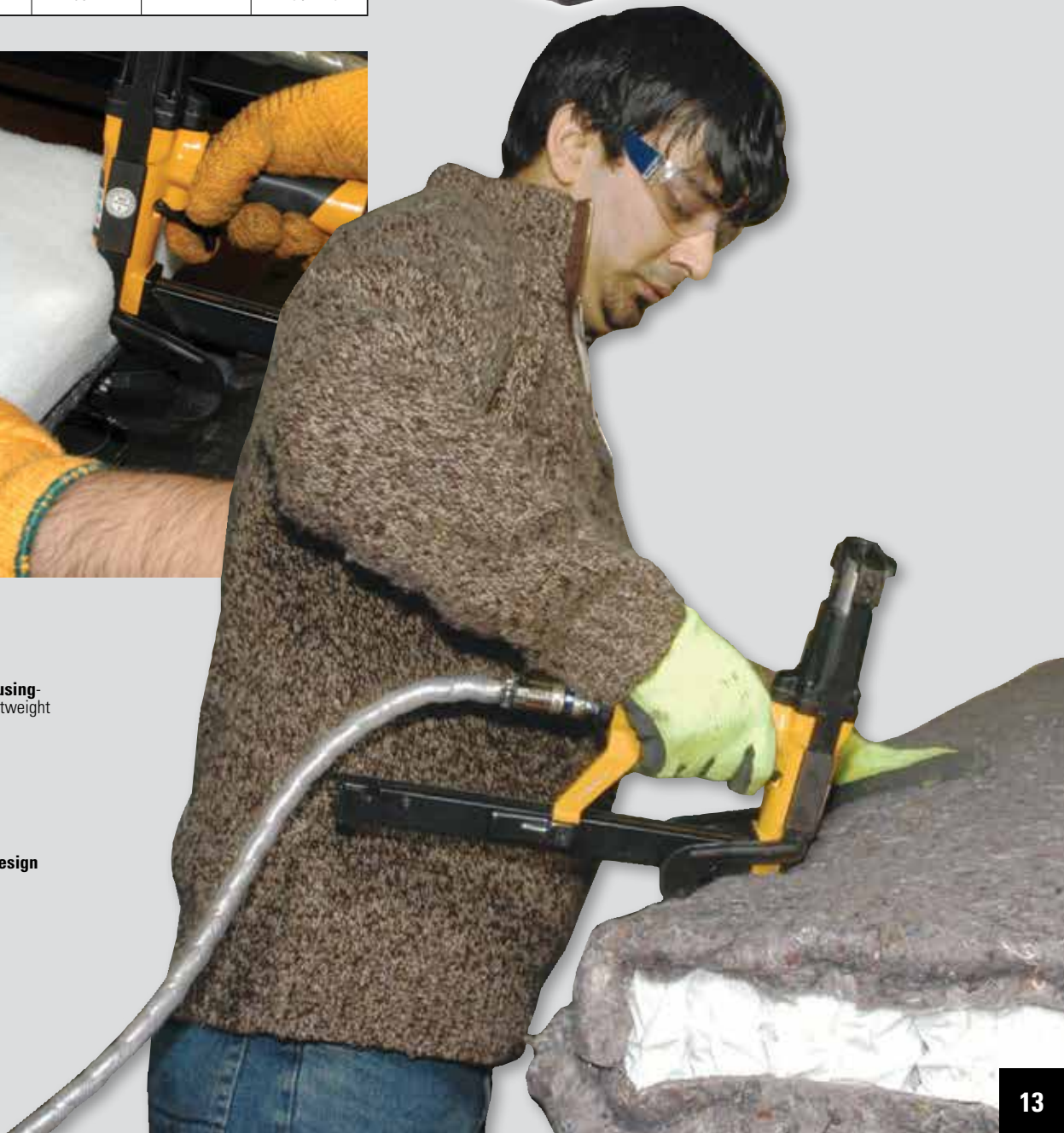

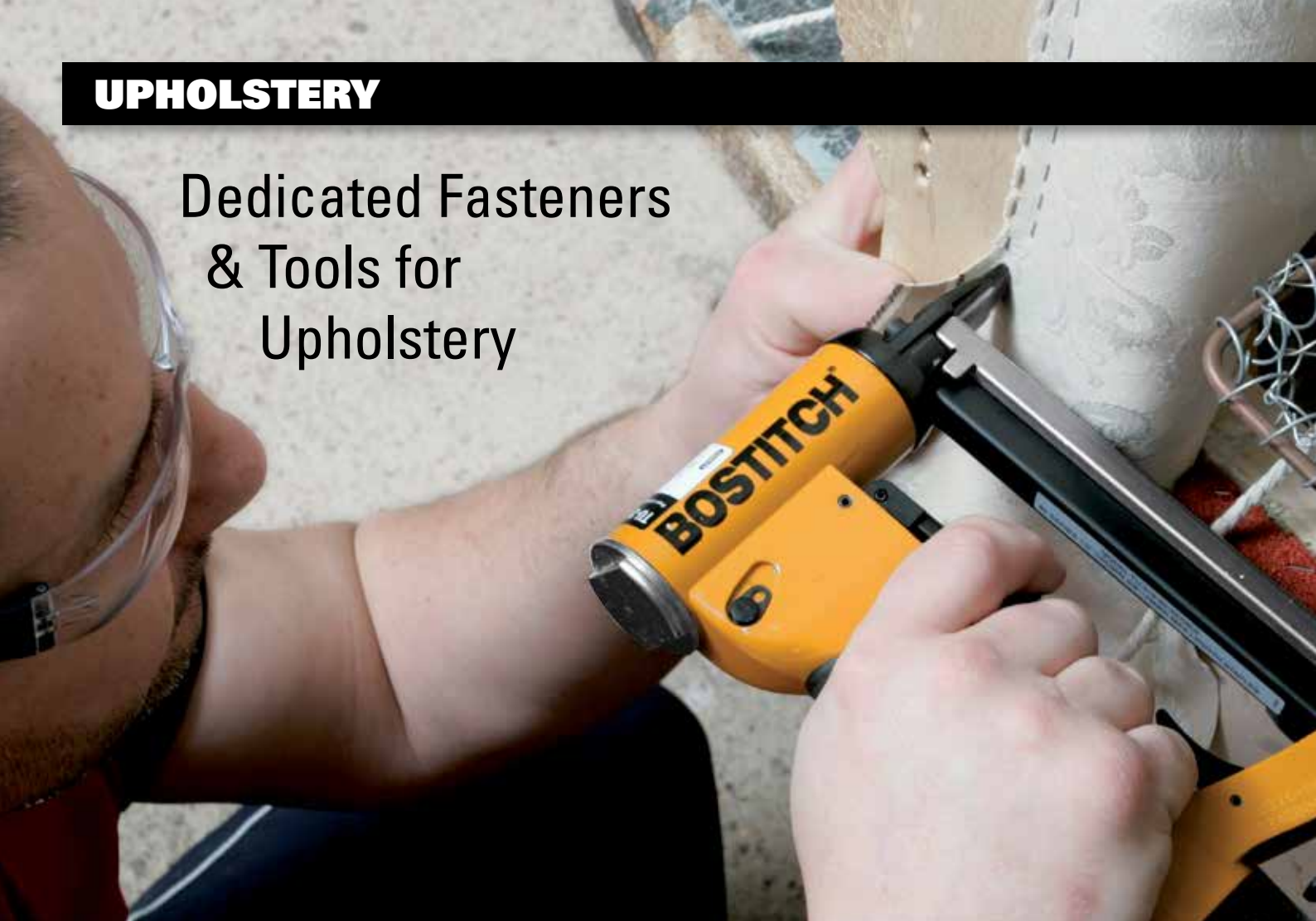

UPHOLSTERY

Dedicated Fasteners & Tools for Upholstery



Through our experience in the upholstery business, we've learned the benchmarks of the Tools & Fasteners the industry demands. Compact design and durability were the starting points in developing our range of lightweight and clean tools. Proven technology and state of the art materials and manufacture are built into every **BOSTITCH** upholstery stapler. We know that downtime is lost revenue, that's why we don't change what works, we improve upon it.





Tool Selection by special feature

EXTENDED NOSE	EXTENDED MAGAZINE	AUTOFIRE TRIP
		
21671B-LN-E	21680B-ALM-E	21671B-A-E
21680B-LN-E	-	21680B-A-E
-	-	21680B-ALM-E

The versatile range for dependable fastening

To select the tool model best suited to your application, use the chart to the right.

Select crown width and check fastener family. Match this with the compatible tools to identify your choice.

Crown Width	4.8mm	9.1mm	12.3mm	12.8mm
Leg Length 4mm to 16mm				
	93 Series Staples	72 Series Staples	84 Series Staples	80 Series Staples
	21697B-E	21671B-E	21684B-E	21680B-E
Compatible Tools		21671B-A-E		21680B-A-E
		21671B-LN-E		21680B-LN-E
				21680B-LM-E
				21680B-ALM-E

Upholstery Staplers 216 Tool Series

The 216 series tools are all new and improved, firm favourites with industry and users alike. Their compact dimensions, robust build quality and feature packed design has been retained and improved with new materials.

The new range encompasses tools driving staples with crown widths from 4.8mm to 12.8mm and leg lengths of 4 to 16mm. A choice of Autofire trip format, Long Magazine and Long Nose designs means you can add real flexibility for your manufacturing process.

Tool Noise & Vibration Data

Tool	Noise			Vibration / Uncertainty m/s ²
	LPA 1sd	LWA 1sd	LPA 1s,1m	
21671B-A-E	68.1	74.8	61.8	<2.5
21671B-E	63.9	74.1	61.1	<2.5
21671B-LN-E	67.3	74.9	61.9	<2.5
21680B-E	68.4	75.8	62.8	<2.5
21680B-A-E	68.4	75.8	62.8	<2.5
21680B-ALM-E	68.7	76.1	63.1	<2.5
21680B-LN-E	68.5	75.9	62.9	<2.5
21680B-LN-E	68.6	75	62	<2.5
21684B-E	68.1	75.7	62.7	2.57 / 1.29
21697B-E	67.3	75.6	62.6	<2.5

Tool Series Features:



UPHOLSTERY

Model designation

As well as the standard models, the options for the 216 Series are designated by the model number. The letter **A** within the model number indicates that the tool has an Autofire trip and the inclusion of **LN** indicates that the tool is fitted with a Long Nose. Similarly, if a model number includes **LM** then it comes with a Long Magazine.

Special Features



LONG NOSE

Specifically developed for long reach applications.

Allows accurate placement of fastener in through deep padding or restricted access applications. Specific tool models including this feature are: **21671B-LN-E 21680B-LN-E**



LONG MAGAZINE

Increased capacity for less reloading. Suited to volume production where access is unrestricted. The specific tool model including this feature are: **21680B-LM-E 21680B-ALM-E**



AUTOFIRE

Designed for production environments where rapid fastening is key, the Autofire feature delivers effortless stapling at up to 300 staples per minute. Specific tool models including this feature are: **21671B-A-E 21680B-A-E 21680B-ALM-E**

Standard Models:

21697B-E



93 Series Staples

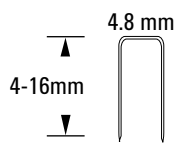

21671B-E



72 Series Staples

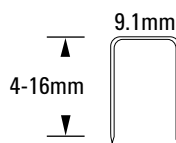

21684B-E



84 Series Staples

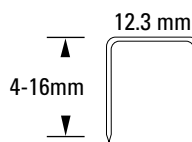

21680B-E



80 Series Staples

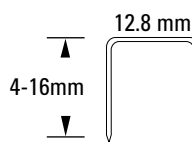

UPHOLSTERY

Long Nose Models:

21671B-LN-E

72 Series Staples

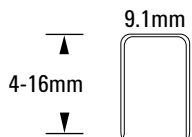

21680B-LN-E

80 Series Staples

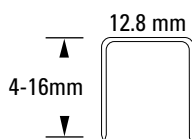

Long Magazine Models:

21680B-LM-E / 21680B-ALM-E

80 Series Staples

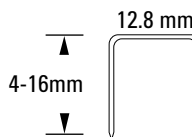

Autofire Models:

21671B-A-E

72 Series Staples

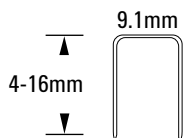

21680B-A-E / 21680B-ALM-E

80 Series Staples

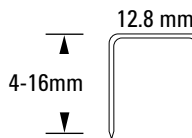

AUTOMATED SOLUTIONS

Years of experience and expertise in customers' fastening processes means that we can provide effective automated solutions for furniture manufacturers. From components to subassembly construction, our units are tailored to your business and are designed to deliver:

- **The most efficient production processes**
- **Lowest overheads**
- **Precision and control**
- **Safer working environments**

All machines are individually designed following an in-depth briefing with our engineers, to ensure your machine matches your exact requirements. This can include options such as:

- **Adjusting the component sizes**
- **Selecting the number of tools**
- **Altering the nailing pattern**
- **Fitting optional units such as stackers, conveyors, sawing systems etc.**

Whatever you're making, we can provide an automated solution to help.



Bespoke machines designed to improve your production process

Staying ahead of the competition

Cost efficient production demands a careful balance of workforce and machinery. At **BOSTITCH**, we're hard at work taking the cost out of production, using automated solutions to get the best from your workers and your production environment.



Flexible manufacture

Increasing diversity of manufacture plus shorter lead times has resulted in the need to be able to make different components quickly and easily, without the need for multiple machine types. With our innovative designers and technicians, we can help you to achieve the manufacturing quality that your business demands.

Efficient control systems

Machines can be designed with varying levels of access to allow management and/or operatives to change and adjust specifications and speed settings according to your needs.

Service and support

Our involvement doesn't end with the installation. From the beginning, our our engineers are committed to finding the best solution for your set up. All machines are tested in our manufacturing plant where operators can be trained prior to installation. Following installation, our engineering team can provide full remote diagnostics to identify and modify any running issues to ensure maximum productivity.



Recognised technology

Machines are made with widely available components for quick and easy servicing and maintenance. These include:

- Touch screens
- Frequency steering components
- Servo steering & motors
- Control components & connections
- Electrical detectors & circuit boards
- Pneumatic fittings & systems

The complete solution

Tools and fasteners are at the centre of our business, and we know how vital a role they play in any automated solution. We design and manufacture an extensive range of tools including:

- Coil & stick nailers
- Brad and finish nailers
- Light, medium and heavy duty staplers
- Carton closing tools
- Spenax tools



Naturally, we also produce the fasteners to match. This includes a wide range of lengths, shank types and finishes for almost any application, for example:

- 12 micron galv and stainless steel finishes
- Clinch and divergent point staples
- Ring, screw & plain shank nails
- Paper, wire and plastic collation

It's because of this extensive range of both tools and fasteners that our engineers are able to specify the most effective combination for each individual client.

All our pneumatic nailers undergo rigorous test procedures to ensure their durability in service and are built with tried and tested components for ultimate reliability.

This makes them ideally suited for automated systems, capable of delivering fast consistent fastening in the most demanding production environments.



AT**Bostitch Österreich**

Stanley Black & Decker Austria GmbH
 Oberlaaer Strasse 248, 1230 Wien
 ÖSTERREICH
 T: +43 1 66 11 66 33
bostitch.de@stanleyworks.com
www.bostitch.at

BE NL**Bostitch Benelux**

Stanley Black & Decker Belgium BVBA
 p/a Egide Walschaertsstraat nr. 16
 2800 Mechelen
 BELGIË
 Tel: +32 15 47 38 00
bostitch.benelux@sbdinc.com
www.stanley-bostitch.be
www.stanley-bostitch.nl

CH**Bostitch Schweiz**

Stanley Works (Europe) GmbH
 Sitz: Dübendorf
 In der Luberzen 42, 8902 Urdorf
 SCHWEIZ
 Tel: +41 (0)44 755 60 70
www.bostitch.ch

CZ SK**Stanley Black & Decker Czech Republic s.řo.**

Türkova 5b, 149 00 Praha 4 - Chodov
 ĀESKÁ REPUBLIKA
 Tel. +420 602 745440
petr.popovsky@sbdinc.com
www.bostitch.cz

DE**Bostitch Deutschland**

Stanley Black & Decker Deutschland GmbH
 Black-&-Decker Str. 40
 65510 Idstein
 DEUTSCHLAND
 Tel: +49 (0) 6126 21-2985
bostitch.de@sbdinc.com
www.stanley-bostitch.de

ES PT**Stanley Black & Decker Ibérica SLU**

Parque de Negocios "Mas Blau"
 Edificio Muntadas
 C/ Bergueda n. 1 Of. A6
 08820 El Prat de Llobregat
 Barcelona,
 ESPAÑA
 Tel: +34 93 217 65 02
iberia.bostitch@sbdinc.com
www.bostitch.es

FR**Bostitch France**

Stanley Black & Decker France SAS
 BP No. 90,
 112 Avenue Charles de Gaulle
 91423 Morangis Cedex
 FRANCE
 Tel: +33 0 (1) 69 10 80 41 ou 40 ou 08
adv-bostitch@sbdinc.com
www.bostitch.fr

GB**Bostitch UK**

Stanley UK Logistics Centre
 Gowerton Road
 Brackmills Industrial Estate
 Northampton
 NN4 7BW
 ENGLAND
 Tel: +44 (0)870 1 630 630
bostitchuksales@sbdinc.com
www.bostitch.co.uk

IT**Stanley Black & Decker Italia S.r.l.**

Via Energy Park 6
 20871 Vimercate (MB)
 ITALIA
 Tel: +39 039 9590.205
 Fax: +39 039 9590.312
bostitch.italy@sbdinc.com
www.bostitch.it

PL**Stanley Black & Decker Polska Sp. z o.o.**

Ul. Postępu 21D
 02-676 Warszawa
 POLSKA
 Tel: +48 22 464 2735
sales.bostitch@sbdinc.com
www.bostitch.pl

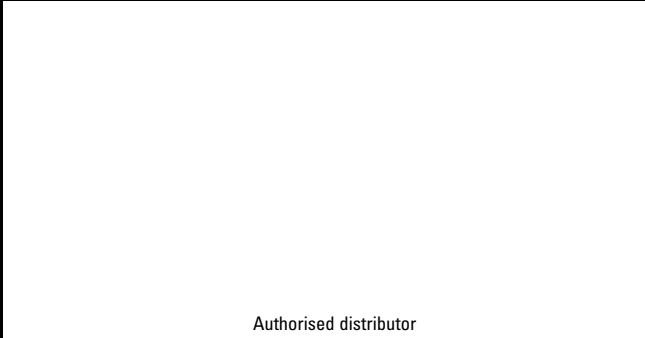

Authorised distributor

BOSTITCH ONE YEAR LIMITED WARRANTY

BOSTITCH is confident of the quality of its products and offers a guarantee for professional users of the product. This guarantee statement is in addition to and in no way prejudices your contractual rights as a professional user or your statutory rights as a private non-professional user. The guarantee is valid within the territories of the Member States of the European Union and the European Free Trade Area. If your BOSTITCH product becomes defective due to faulty materials or workmanship within 12 months from the date

of purchase, BOSTITCH guarantees to replace all defective parts free of charge or – at our discretion – replace the unit free of charge provided that:

- The product has not been misused;
- The product has been subject to fair wear and tear; Driver blades, bumpers, and O-rings are considered normally wearing parts and are excluded.
- Repairs have not been attempted by unauthorised persons;

- Proof of purchase is produced.
- The product is returned complete with all original components
- The product is returned at your expense together with proof of purchase to our regional repair centre, or an authorised warranty centre

If you wish to make a claim, contact your seller or check the location of your nearest authorised BOSTITCH repair agent or contact your BOSTITCH office at the address above.

All tool data shown is for comparative purposes only. Full Health & Safety technical data is available on request. Features and specifications subject to modification without notice.

www.bostitch.co.uk

FT042015/FURN/UK