



INDUSTRIAL 25" PLANER

MPLAN25-10-1-0130

MPLAN25-15-3-0130

OPERATING MANUAL

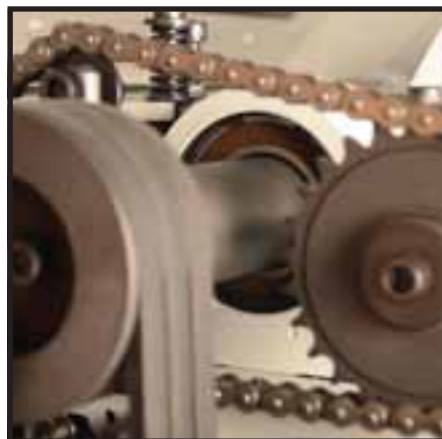
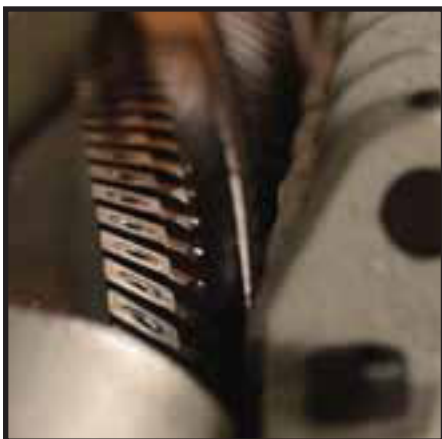

WARNING

Read this manual completely and observe all warning labels on the machine. Every attempt to provide a safe, reliable, easy-to-use piece of machinery. Safety, however, is ultimately the responsibility of the individual machine operator. As with any piece of machinery, the operator must exercise caution, patience, and common sense to safely run the machine. Before operating this product, become familiar with the safety rules in the following sections.

Safety Rule

Always keep guards and covers in place and in proper operating condition.

1. If you are not properly trained in the use of a planer do not use until the proper training has been obtained.
2. Read, understand and follow the safety instructions found in this manual. Know the limitations and hazards associated with this machine.
3. Make certain that the machine frame is electrically grounded and that a ground lead is included in the incoming electrical service. In cases where a cord and plug are used, make certain that the grounding plug connects to a suitable ground. Follow the grounding procedure indicated in the National Electrical Code.
4. Wear an approved safety shield, goggles, or glasses to protect eyes. Common eyeglasses are only impact-resistant, they are not safety glasses.
5. Before operating the machine, remove tie, rings, watch and other jewelry and roll up sleeves above the elbows. Remove all loose outer clothing and confine long hair. Protective type footwear should be used. Where the noise exceeds the level of exposure allowed in Section 1910.95 of the OSHA Regulations, use hearing protective devices. Do not wear gloves.
6. Keep the machine guards and covers in place for every operation. If any guards and covers are removed for maintenance, DO NOT OPERATE the machine until the guards and covers are reinstalled.
7. Keep the floor around the machine clean and free of scrap material, saw dust, oil and other liquids to minimize the danger of tripping or slipping. Be sure the table is free of all scrap, foreign material and tools before starting the planer. Make certain the work area is well lighted and that a proper exhaust system is used to minimize dust. Use anti-skid floor strips on the floor area where the operator normally stands and mark off machine work area. Provide adequate work space around the machine.
8. Maintain a balanced stance and keep your body under control at all times.
9. Before turning on machine, remove all extra equipment such as keys, wrenches, scraps, and cleaning rags away from the machine.
10. Give the work you are doing your undivided attention. Looking around, carrying on a conversation, and "horseplay" are careless acts that can result in serious injury.

11. Before performing any service, maintenance, adjustments or when changing knives disconnect the machine from power source. A machine under repair should be RED TAGGED to show it should not be used until the maintenance is complete.
12. Do not plane boards with loose knots, nails or any foreign material in the workpiece. Irregular, or warped stock should be jointed first on one side before planing a parallel surface.
13. If the operator leaves the machine area for any reason, the planer should be turned "off" and the cutterhead should come to a complete stop before their departure. In addition, if the operation is complete, they should clean the planer and the work area. NEVER clean the planer with power "on" and never use hands to clear sawdust and debris; use a brush or air hose.
14. Use only genuine Machinery factory authorized replacement parts and accessories; otherwise the warranty and guarantee is null and void.
15. Do not use this planer for other than its intended use. If used for other purposes, disclaims any real or implied warranty and holds itself harmless for any injury or damage which may result from that use.
16. Do not operate this machine while under the influence of drugs, alcohol, or any medication.
17. This machine is designed for planing wood products only. Do not use to plane any kind of substance other than wood.
18. Never start the planer while a workpiece is in contact with the cutterhead or knives.
19. Always feed workpiece against the rotation of the cutterhead.
20. Some dust created by power sanding, sawing, grinding, drilling and other construction activities contains chemicals known to cause cancer, birth defects or other reproductive harm. Some examples of these chemicals are:
 - Lead from lead-based paint.
 - Crystalline silica from bricks and cement and other masonry products.
 - Arsenic and chromium from chemically-treated lumber.Your risk from these exposures varies, depending on how often you do this type of work. To reduce your exposure to these chemicals, work in a well-ventilated area, and work with approved safety equipment, such as those dust masks that are specifically designed to filter out microscopic particles.

Familiarize yourself with the following safety notices used in this manual:

CAUTION: (This means that if precautions are not heeded, it may result in minor or moderate injury and/or possible machine damage)

WARNING: (This means that if precautions are not heeded, it could result in serious injury or possibly even death).

Table of Contents

Page

Safety Rule.....	1
Uncrating the Machine.....	4
Machine Preparation and Setup	4
Dust Chute Assembly	5
Table Roller Handle Assembly.....	5
Control Panel.....	5
Digital Controller	5
Changing Units of Measure	6
Calibrating the Display.....	6
Planning to a Specific Thickness	6
Raising and Lowering Table	7
Adjusting Thickness Scale.....	7
Table Roller Adjustment	7
Changing Feed Rate.....	7
Table Stop.....	7
Opening Hood	7
ShearTec II CUTTERHEAD.....	8
Setup of Feed Rollers, Chip Breaker and.....	9
Pressure Bar	9
Anti-Kickback Fingers.....	10
Adjustment of In-Feed Roller	10
Adjustment of Chipbreaker	10
Adjustment of Pressure Bar	11
Adjustment of Out-feed Rollers.....	11
Helical Cutterhead.....	12
V-Belt Adjustment.....	12
Adjusting Table Gibs.....	13
Adjusting Table Rollers.....	13
Maintenance.....	14
Troubleshooting.....	15
PARTS DIAGRAMS.....	16
PARTS LIST FOR MPLAN25-15-3-0130	21

Uncrating the Machine

Retain all packaging materials in case it becomes necessary to ship the machine to another site.



Machine Preparation and Setup

WARNING!

The equipment used to lift this machine must have a rated capacity at, or above the weight of the planer. Failure to comply may cause serious injury!

The planer can be lifted from over head using slings and the four lifting hooks A.

The planer must be positioned on a smooth, level surface. Install the leveling pads B under the four corners of the planer.

Clean all rust protected surfaces with a commercial solvent. Do not use acetone, gasoline, lacquer thinner or any type of flammable solvent, or a cleaner that may damage paint. Cover cleaned surfaces with WD-40 or a 20W machine oil.

Place a level on the table of planer and adjust leveling bolts C until the machine is resting level. Tighten the hex nuts D against the base of the planer to keep the leveling bolts from turning (Fig. 1)

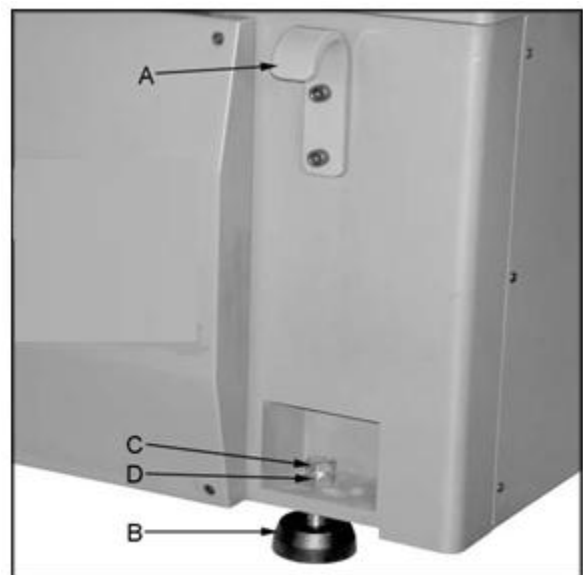
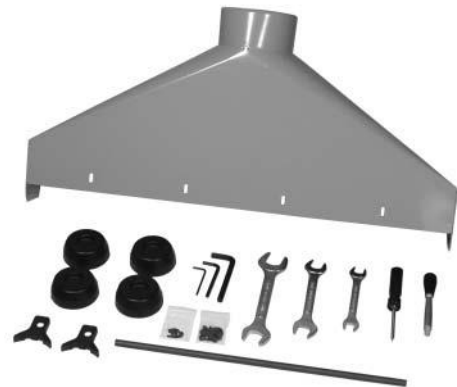

Figure 1

Dust Chute Assembly

Mount the dust chute to the planer hood with eight M6x10 hex head screws B. Make sure the dust collection system has sufficient capacity and suction for your planer. Always turn on the dust collection system before starting the planer. (Fig. 2)

Table Roller Handle Assembly

Thread the handle C(Fig. 3) into the hub.

Control Panel

In Fig. 3

- D: Emergency Stop Button: Stops all functions of machine, but the planer still has power. To reset rotate switch clockwise until the button pops out.
- E: Main Motor: Starts rotation of Cutterhead. Will not work if the “Emergency Stop” switch is engaged, or hood is open.
- F: Digital Thickness Controls: Displays and controls table position, units, etc..
- G: Table Up: Raises the table.
Note: Table will contact the upper limit switch at about 5/8”. You can continue to raise manually by using the handwheel.
- H: Table Down: Lowers the table.
Note: Table will contact the lower limit switch at about 8-5/8”. You can continue to lower manually by using the handwheel.

Digital Controller

In Fig. 4

- I: LED readout displays the thickness setting.
- J: The digital thickness controls are capable of operating and displaying in either inches, or millimeters by pressing the “Units” button.
- K: The “+” and “-” buttons can be used to move the table up or down without keying in an exact numerical thickness value.
Note: The “-” button raises the table to subtract from workpiece thickness. The “+” button lowers the table.
- L: “Start” button is used to begin table travel after a numeric value has been keyed in.
- M: The “Stop” button is used to stop the table travel after it has started.
- N: The “Set” button is used when calibrating or setting the thickness scale.

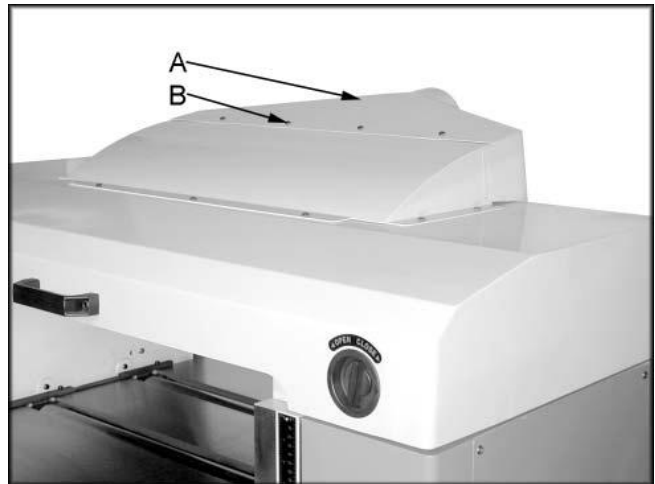

Figure 2



Figure 3



Figure 4

Changing Units of Measure

Press unit button A (Fig. 5) to toggle back and forth between inches and millimeters.

Calibrating the Display

The following sections will describe the use of a calibrating board. The calibrating board should be made of a hardwood and have one side that has been run through a jointer.

1. With the planer turned "OFF – cutterhead NOT spinning", place your calibrating board jointed surface down on the table and slide it into the machine.
2. Use the table "UP" button to raise the table so that the in-feed roller is about 1/32" above the calibrating board.
3. Remove calibrating board from planer and turn the planer "ON".
4. Use the table "UP" button to raise the table about 0.1", as indicated by LED and run the calibrating board through the planer.
5. Repeat Step 4 until the planer removes the entire top surface of your calibrating board.
6. Measure the thickness of the board using a pair of calipers.
7. Press the "SET" button C (Fig.5) and then type in the measured thickness from step 6. Press the "SET" button again and hold in until the decimal point stops blinking (about three seconds).

Planning to a Specific Thickness

1. Measure thickest section of the workpiece.
2. Subtract the amount you wish to remove from the current thickness of the workpiece.
3. Press the "SET" button and enter the amount from step 2.
4. Press "START" button D (Fig. 5) to begin the table movement up, or down until the set value is achieved.

Note: Do not feed material through the planer while the table is raising or lowering.



Figure 5

Fraction	Decimal	Metric
1/32	0.031	0.794
1/16	0.063	1.588
3/32	0.094	2.381
1/8	0.125	3.175
5/32	0.156	3.969
3/16	0.188	4.763
7/32	0.219	5.556
1/4	0.250	6.350
9/32	0.281	7.144
5/16	0.313	7.938
11/32	0.344	8.731
3/8	0.375	9.525
13/32	0.406	10.319
7/16	0.438	11.113
15/32	0.469	11.906
1/2	0.500	12.700
17/32	0.531	13.494
9/16	0.563	14.288
19/32	0.594	15.081
5/8	0.625	15.875
21/32	0.656	16.669
11/16	0.688	17.463
23/32	0.719	18.256
3/4	0.750	19.050
25/32	0.781	19.844
13/16	0.813	20.638
27/32	0.844	21.431
7/8	0.875	22.225
29/32	0.906	23.019
15/16	0.938	23.813
31/32	0.969	24.606
1	1.00	25.400

Figure 6

Raising and Lowering Table

Turn the handwheel A (Fig. 7) clockwise to raise the table. One revolution equals 1/32" or 0.03".

Note: The handwheel is spring loaded. Push in on the handwheel and rotate until the pins engage the detents.

Adjusting Thickness Scale

1. Run a board through the planer and measure the thickness of the planed board with a pair of calipers.
2. Adjust the pointer B (Fig. 7) by loosening the screw that holds it in place.

Note: This measurement should be the same as digital readout.

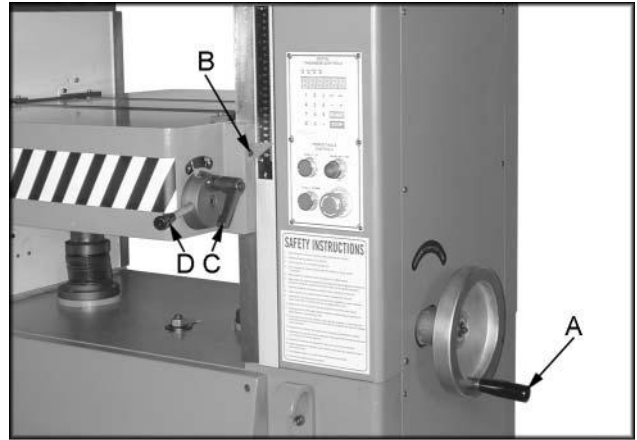

Figure 7

Table Roller Adjustment

Loosen the handle C and move the table rollers up, or down by raising, or lowering the handle D. When you reach the desired position tighten the handle (Fin. 7).

The rollers are usually set higher when planing rough stock. When planing smooth stock the table rollers should be set slightly above, or flush with the table.

Changing Feed Rate

The planer has three selectable feed speeds that feed stock at 20, 25 and 30 feet per minute. To adjust speed, turn lever E (Fig. 8) until it clicks into place. **Change feed speed only while the feed system is RUNNING!**

Table Stop

The socket head cap screws F (Fig. 8) act as a stop and prevent you from running the table into the cutting and feeding assembly.

Opening Hood

Turn the locks G to open the hood. The hood will open automatically. Use the handle H to shut the hood (Fig. 8).

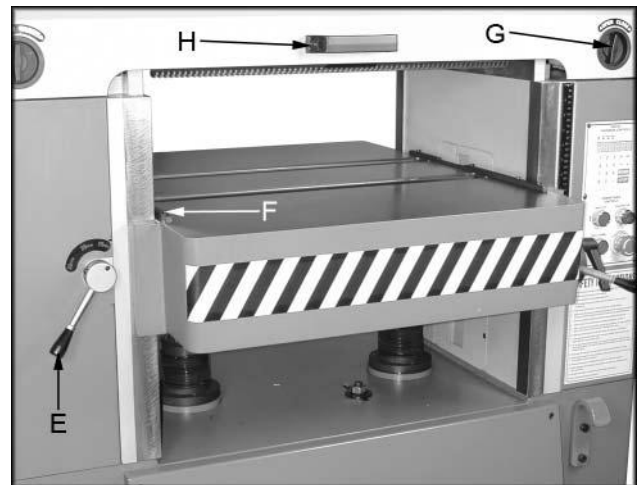

Figure 8

ShearTec II CUTTERHEAD

Knife inserts are dangerously sharp. Use extreme caution when inspecting, removing, or replacing knife inserts.

The knife inserts on the 25" Planer are four-sided. When dull, simply remove each insert, rotate it 90° for a fresh edge, and re-install it. No further adjustment is necessary. Use the two provided torx wrench to remove the knife insert screw. Use one of the torx wrenches to help hold the cutterhead in Position, and the other to remove the screw. See Fig. 9. It is advisable to rotate all inserts at the same time to maintain consistent cutting. However, if one or more knife inserts develops a nick, rotate only those inserts that are affected. Each knife insert has an etched reference mark so you can keep track of the rotations.



IMPORTANT: When removing or rotating inserts, clean saw dust from the screw, the insert, and the cutterhead platform. Dust accumulation between these elements can prevent the insert from seating properly, and may affect the quality of the cut.

Before installing each screw, lightly coat the screw threads with machine oil and wipe off any excess. Securely tighten each screw which holds the knife inserts before operating the jointer!

Make sure all knife insert screws are tightened securely. Loose inserts can be propelled at high speed from a rotating cutterhead, causing injury.

Warning: Disconnect machine from power source.

Setup of Feed Rollers, Chip Breaker and Pressure Bar

WARNING!

Disconnect machine from the power source before performing any adjustments or maintenance. Failure to comply may cause serious injury!

The planer comes set up from the factory and shouldn't need any adjustment.

If you find adjustment is necessary, follow the below listed sections for setting the infeed roller, chip breaker, pressure bar and outfeed rollers.

Make a hardwood block to the specifications in drawing Fig.13. You can use this wood gauge along with 0.02" feeler gauge to set the planer up as shown in Fig. 12.

Setup for planing applications. Depending on the stock and cutterhead you may find that a different setup may work better for your particular planing operation.

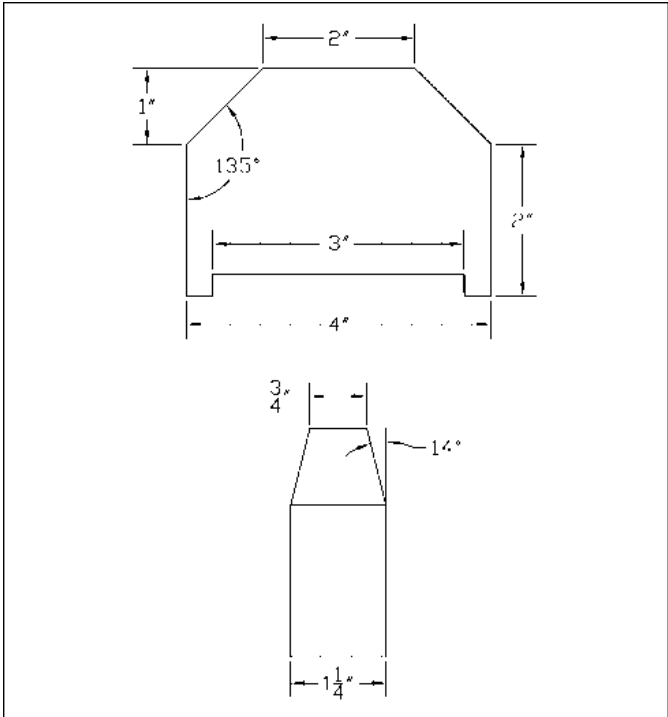

Figure 13

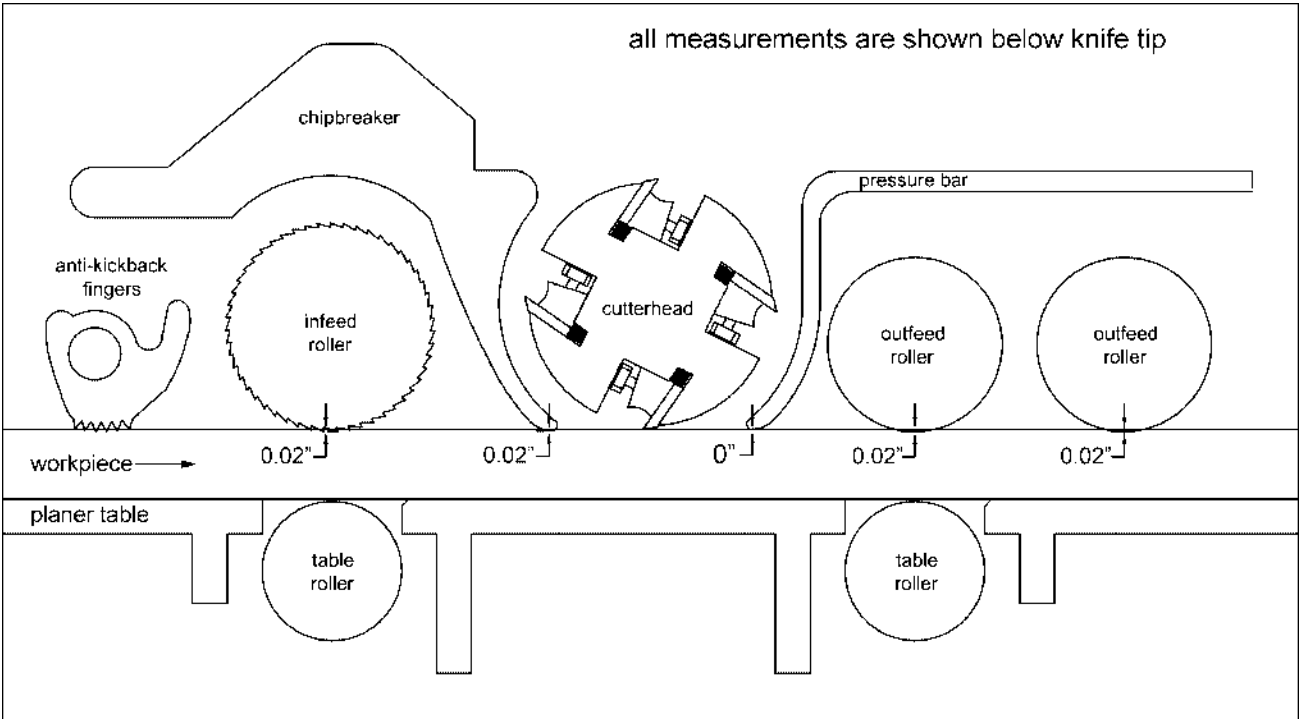

Figure 12

Anti-Kickback Fingers

Anti-kickback fingers help prevent stock from being kicked out of the machine towards the user. Keep the fingers clean and free from sawdust, pitch gum, etc. so they operate smoothly.

Adjustment of In-Feed Roller

The in-feed roller should be set 0.02" below the lowest point of knife. Make sure the knives are set properly see the "Setting / Changing Knives" section on page 11 prior to making any adjustments.

1. Disconnect machine from power source.
2. Place a hard wood gauge (A, Figure 14) under a knife in cutterhead. Place a 0.02" feeler gauge (B, Figure 14) on top of wood block and raise table until feeler gauge contacts the knife in its lowest position.
3. Remove feeler gauge and place wood block under the left side of in-feed roller. The top of wood gauge should just contact the in-feed roller. If it doesn't, loosen jam nut (C, Figure 15) and turn the adjusting screw (D, Figure 15) to raise, or lower the in-feed roller until it contacts wood gauge. Repeat for opposite side of the in-feed roller.

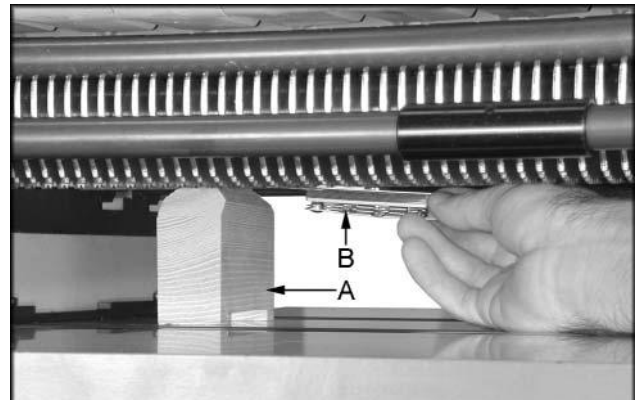

Figure 14

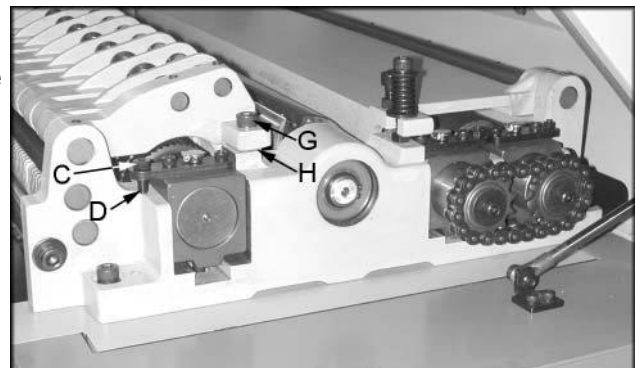

Figure 15

Adjustment of Chipbreaker

Chipbreaker should be set 0.02" below the lowest point of knife. Make sure the knives are set properly see the "Setting / Changing Knives" section on page 11 prior to making any adjustments.

1. Disconnect machine from power source.
2. Place a hard wood gauge (A, Figure 14) under a knife in the cutterhead. Place a 0.02" feeler gauge (B, Figure 14) on top of wood block and raise table until the gauge contacts the knife in its lowest position.
3. Remove feeler gauge and place wood gauge (E, Figure 16) under the left side of chipbreaker (F, Figure 16). The top of the wood gauge should just contact the chipbreaker. If it doesn't, remove the socket head cap screw (G, Figure 15) and remove washer (H, Figure 15), or replace with shim of proper thickness to raise, or lower the chipbreaker until it contacts the wood gauge. Repeat for opposite side of the chipbreaker.

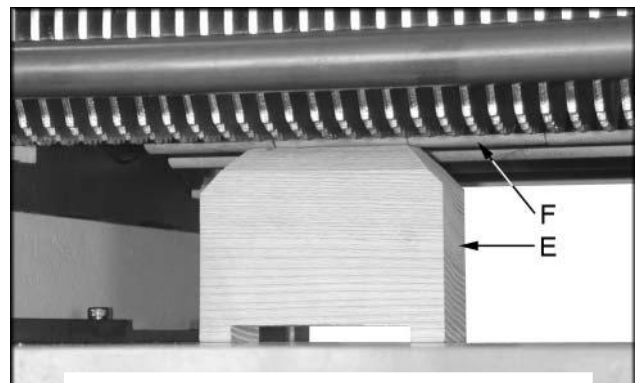

Figure 16

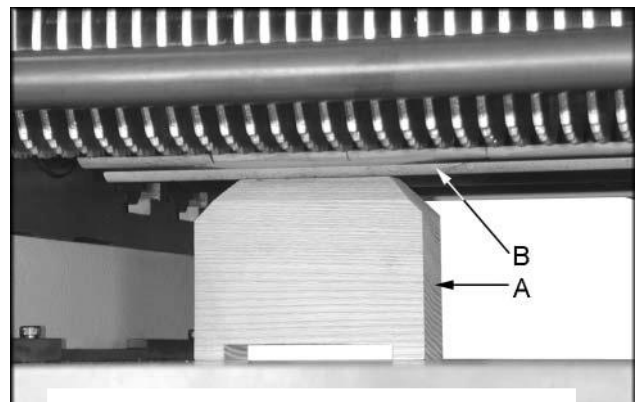

Figure 17

Adjustment of Pressure Bar

The pressure bar should be set even with the lowest point of knife.

1. Disconnect machine from power source.
2. Place a hard wood gauge under a knife in cutterhead. Raise table until wood gauge contacts the knife in its lowest position.
3. Place wood block A, Figure 17) under the left side of pressure bar (B, Figure 17). The top of wood gauge should just contact the pressure bar. If it doesn't, loosen jam nut (C, Figure 18) and turn the adjusting screw (D, Figure 18) to raise, or lower the pressure bar until it contacts wood gauge. Repeat for opposite side of the pressure bar.

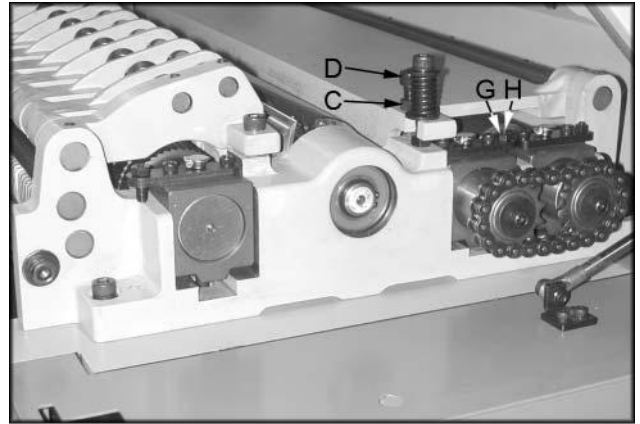

Figure 18

Adjustment of Out-feed Rollers

The out-feed rollers should be set 0.02" below the lowest point of knife. Make sure the knives are set properly see the "Setting / Changing Knives" section on page 11 prior to making any adjustments.

1. Disconnect machine from power source.
2. Place a hard wood gauge (A, Figure 14) under a knife in the cutterhead. Place a 0.02" feeler gauge (B, Figure 14) on top of wood block and raise table until the gauge contacts the knife in its lowest position.
3. Remove feeler gauge and place wood block (E, Figure 19) under the left side of out-feed roller (F, Figure 19). The top of wood gauge should just contact the out-feed roller. If it doesn't, loosen jam nut (G, Figure 18) and turn the adjusting screw (H, Figure 18) to raise, or lower the out-feed roller until it contacts wood gauge. Repeat for opposite side of the out-feed roller.
4. Repeat for second out-feed roller

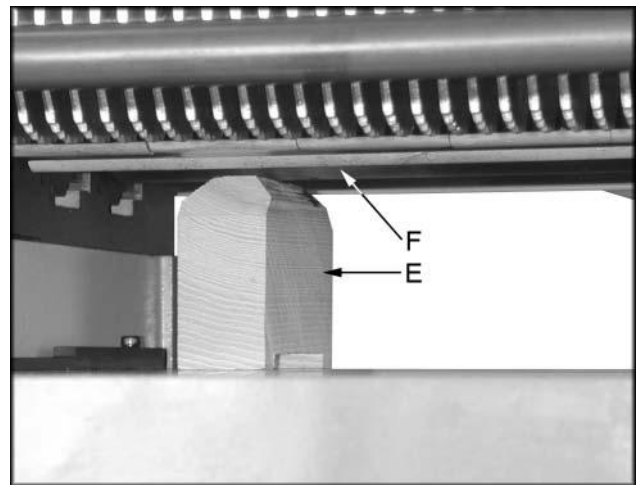

Figure 19

Helical Cutterhead

WARNING!

Knives are extremely sharp. Be very careful when handling knives. Failure to comply may cause serious injury!

The helical cutterhead is set-up with the same relationship to the in-feed roller, chipbreaker, pressure bar and outfeed rollers as the straight knife cutterhead. The planer comes set up from the factory and shouldn't need any adjustment.

If you find adjustment is necessary, follow the steps on pages 10-11 for setting the in-feed roller, chipbreaker, pressure bar and outfeed rollers in relation to the helical cutterhead.

When it is time to rotate the carbide knives ALL knives must be rotated at the same time. This is the same when replacing carbide knives ALL knives must be replaced at the same time. Mark the knives with a marker so you know which knives have been rotated. You can rotate the knives three times before replacing. Use the provided tork wrench to rotate, or remove knives.

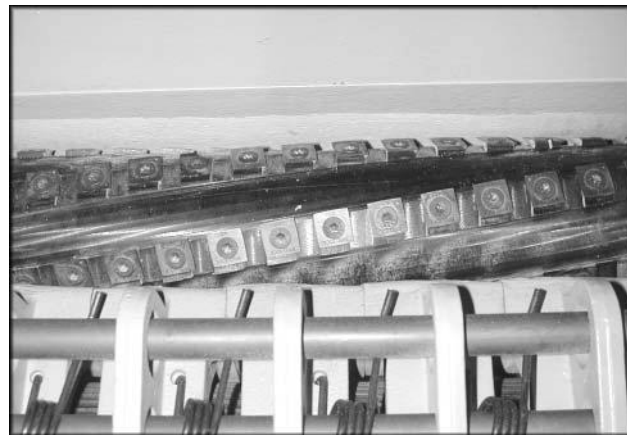

Figure 20

V-Belt Adjustment

Three V-belts (A, Figure 21) drive the cutterhead. The single V-belt (B, Figure 21) drives the in-feed and out-feed rollers. Belt tension has been set at the factory. If the belts have stretched and need adjustment.

1. **Disconnect machine from power source.**
2. Open lower rear, and lower left-hand side panels. Loosen and tighten four adjustment nuts (C, Figure 21) to move motor plate up, or down to increase, or decrease belt tension. Tighten nuts against motor plate after adjustment is made.
3. Belts are tensioned properly when moderate finger pressure can deflect the v-belts about a 1/4"-1/2" midway between the pulleys.

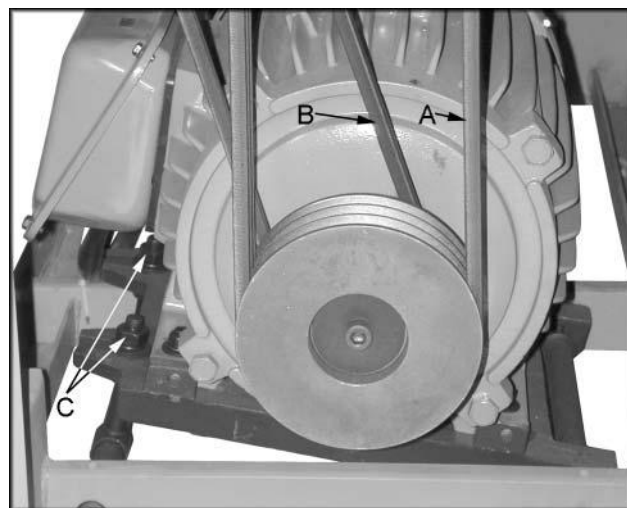

Figure 21

Adjusting Table Gibs

Adjust gibs (D, Figure 22) by loosening the hex nuts (E, Figure 22), and turning gib screws (F, Figure 22) so that the ways (G, Figure 22) are lightly contacted. You should be able to get a 0.005" feeler gauge in between the gib and way.

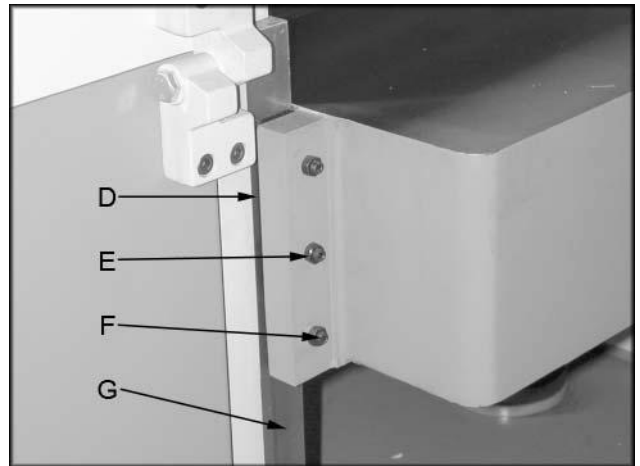

Figure 22

Adjusting Table Rollers

The table rollers come pre-set from the factory and shouldn't need any adjustment. If you find adjustment is necessary, follow the below listed steps.

1. Lay a straight edge (A, Figure 23) on the table across the roller (B, Figure 23).
2. Raise the rollers until it contacts the straight edge and lock the handle. The pointer should be set at "0". If not adjust the pointer to read zero. Note: Spin the roller by hand to know when roller makes contact with the straight edge.
3. Move straight edge to the opposite side of bed roller and check to see that the roller just contacts straight edge. If not loosen the hex nut (C, Figure 24) and turn the hex cap bolt (D, Figure 24) to raise or lower the bed roller until it just contacts the straight edge.

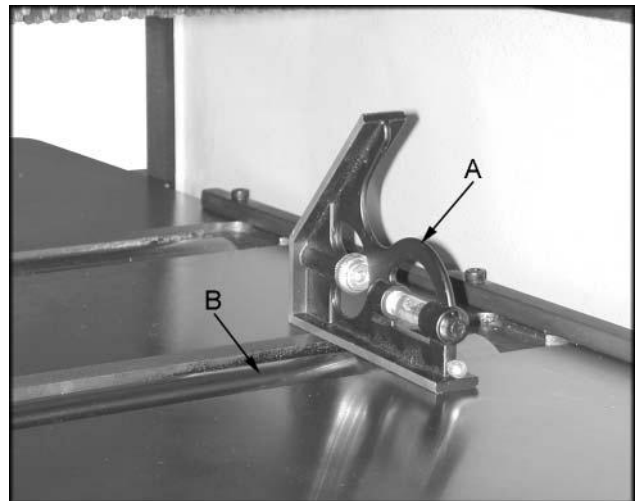

Figure 23



Figure 24

Maintenance

WARNING!

Disconnect the machine from power source before proceeding with any maintenance, lubrication or assembly! Failure to comply may cause serious injury!

Periodic, or regular inspections are required to ensure that the machine is in proper adjustment, and that all hardware is tight.

Clean out-feed rollers and table with a non-flammable solvent to remove pitch, gum and other unwanted build-up.

Periodically clean the inside of the machine for dust control.

Keep pulleys and belts free from dirt, dust, oil and grease. Replace worn V-belts as needed.

There are three limit switches on the planer, one that triggers if the hood is open, and a raising and a lowering limit switch to prevent the table from automatically traveling too far. Keep these clean and blown out with an air hose.

Lubrication

Add a few drops of medium weight oil to the six oil cups (A, Figure 25) weekly.

Lubricate the two table elevation screws (B, Figure 26) as needed. Raise the table and remove the two screws holding the top of the accordion cover (C, Figure 26) in place. Pull the cover down and lightly grease the elevating screws, see Figure 26.

Use an oiled cloth to wipe the ways (D, Figure 26) weekly.

Lubricate the chain system with an oiled cloth as needed.

The gear box oil should be changed once a year. Remove the drain plug (E, Figure 27) to drain the oil. Refill the gear box with 60-90 weight gear oil through the fill hole (F, Figure 27) until the sight glass reads full. The sight glass (G, Figure 27) should be checked periodically and oil added as necessary.

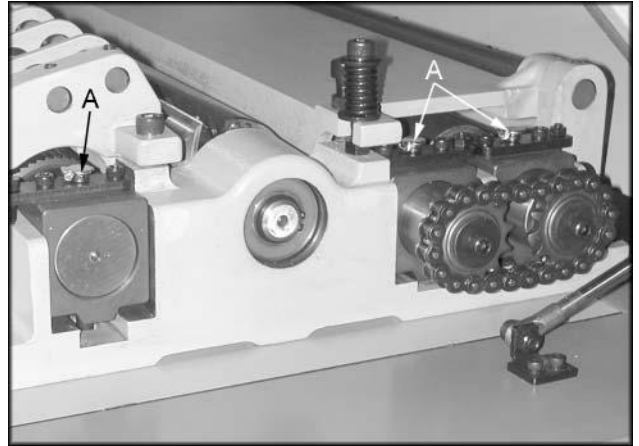

Figure 25

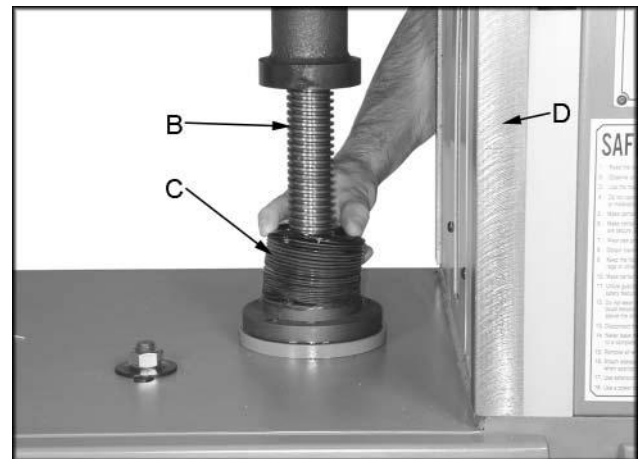

Figure 26

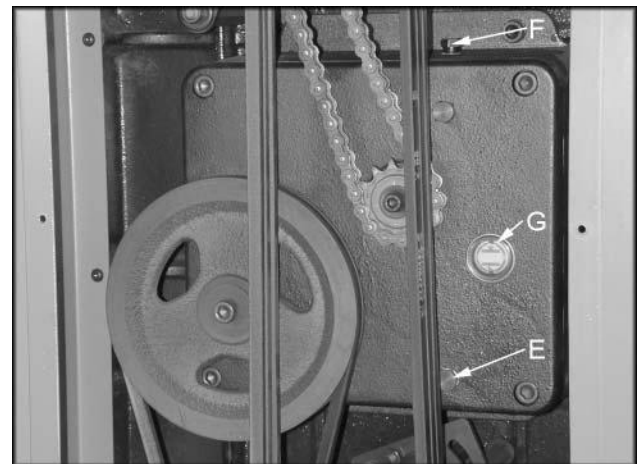

Figure 27

Halted Feeding

If the in-feed roll takes stock away from you while feeding, then feeding stops before contacting the knives, the chipbreaker is probably too low. Or the in-feed roller is not set low enough, or does not have enough pressure. In a similar situation, the in-feed roll takes the stock, the chipbreakers lift, and stops as you hear the knives contact the material. In this case the pressure bar is too low. Follow the steps on pages 12-14 for setting the in-feed roller, chipbreaker, pressure bar and outfeed rollers in relation to the cutterhead.

Troubleshooting

Description of Symptoms	Possible Cause	Corrective Action
Machine will not start	<ol style="list-style-type: none"> 1. Fuse blown or circuit breaker tripped 2. Cord Damaged 3. Not connected to power source 4. Connected to wrong voltage 	<ol style="list-style-type: none"> 1. Replace fuse or reset circuit breaker 2. Have cord replaced 3. Check connection 4. Check voltage 5. Close top cover
Cutterhead does not come up to speed	<ol style="list-style-type: none"> 1. Low current 2. Motor not wired for correct voltage 	<ol style="list-style-type: none"> 1. Contact local electric company 2. Refer to motor nameplate for
Workpiece stops when feeding	<ol style="list-style-type: none"> 1. Too much material being removed in one pass 2. Chipbreaker or pressure bar set too low 3. Insufficient pressure on in-feed or out-feed rollers 	<ol style="list-style-type: none"> 1. Reduce the amount of material being removed 2. Raise the Chipbreaker or pressure bar per Figure 12, page 12 3. Increase pressure on in-feed
Snipe	<ol style="list-style-type: none"> 1. Incorrect setting for in-feed, out-feed rollers, pressure bar or chipbreaker 2. Inadequate support of long 	<ol style="list-style-type: none"> 1. Adjust feed system per Figure 12, page 12 2. Support long boards with extension rollers
Fuzzy Grain	<ol style="list-style-type: none"> 1. Planing wood with a high moisture content 2. Dull knives 	<ol style="list-style-type: none"> 1. Allow wood to dry properly 2. Sharpen knives
Poor feeding of lumber	<ol style="list-style-type: none"> 1. Inadequate feed roll pressure 2. Planer bed dirty 3. V-belts slipping 4. Dirty feed rollers 5. Incorrect setting for in-feed, out-feed rollers, pressure bar or chipbreaker 	<ol style="list-style-type: none"> 1. Adjust feed roll tension or lower feed rollers 2. Clean pitch and residue off table with a non-flammable solvent 3. Increase v-belt tension 4. Clean feed rollers with a non-flammable solvent 5. Adjust feed system per Figure 12, page 12

PARTS DIAGRAMS

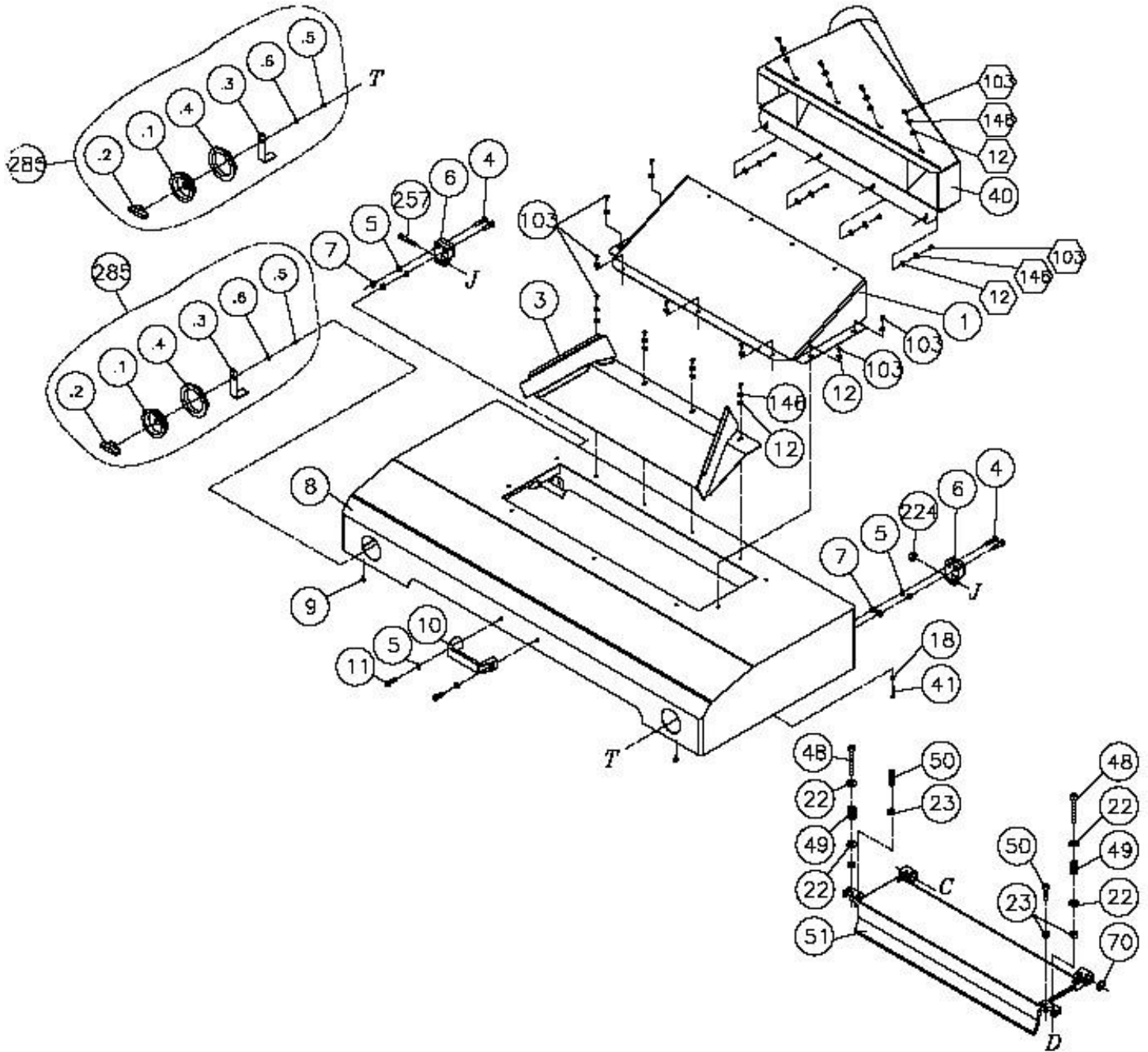

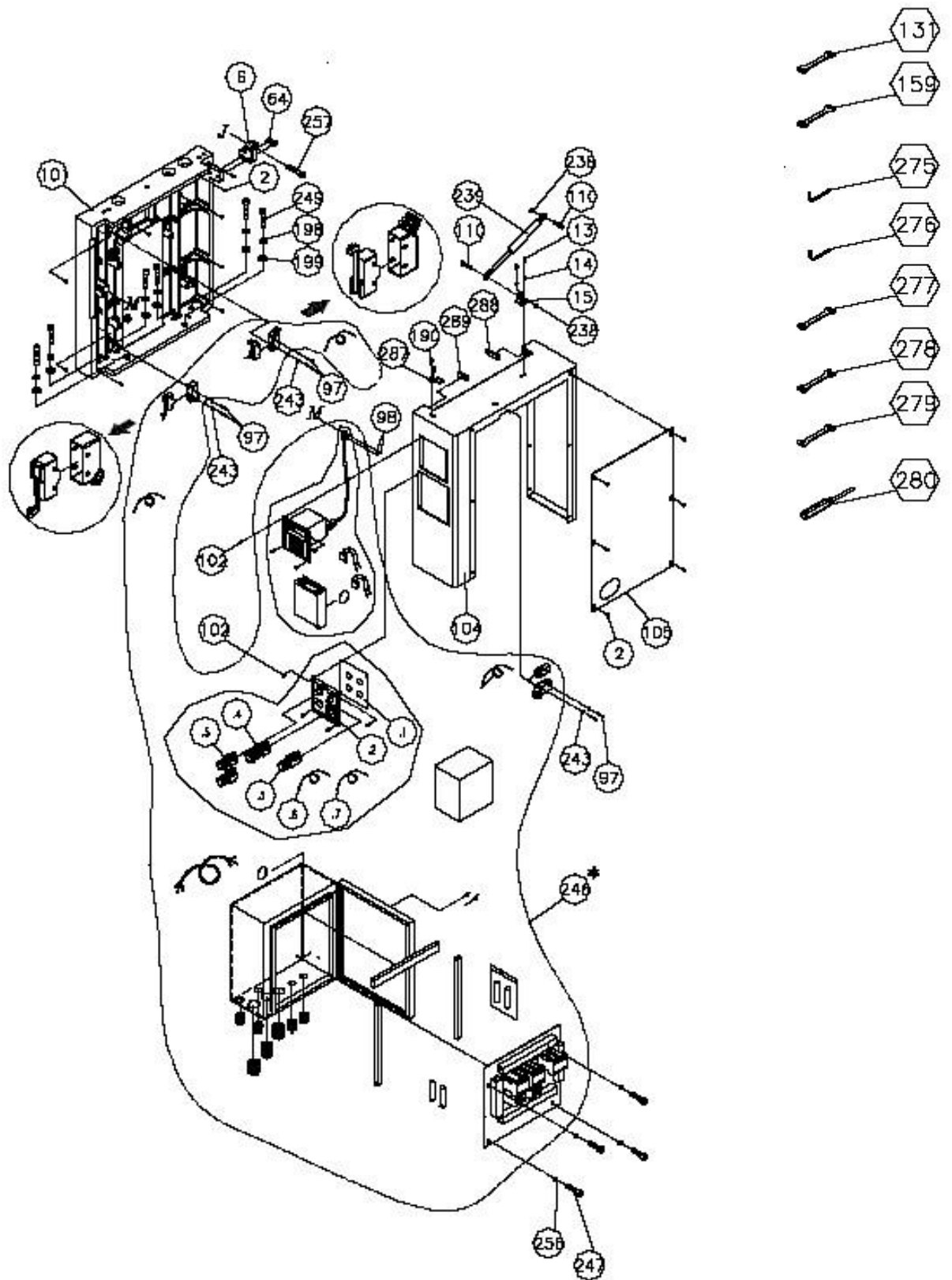

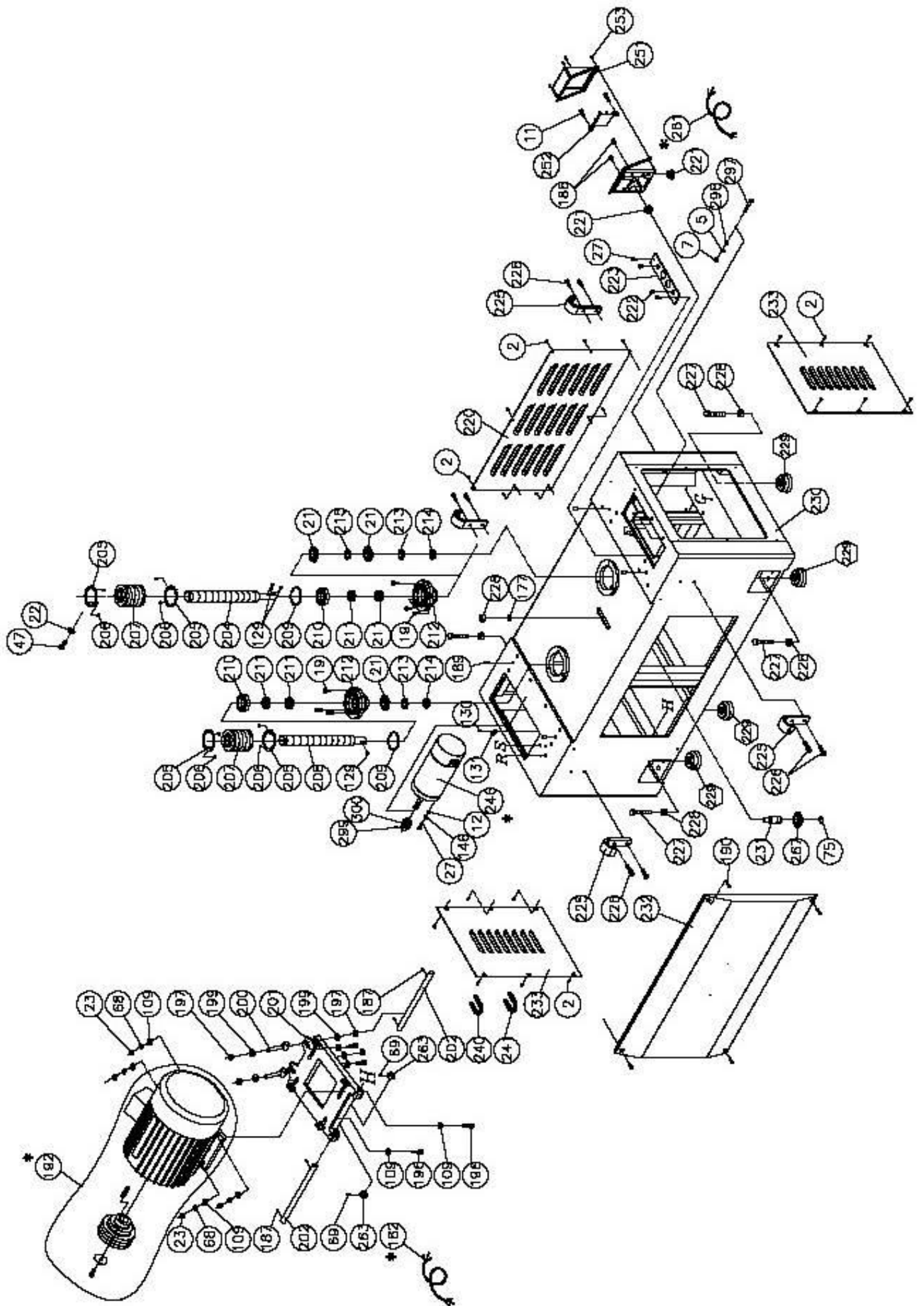

PARTS LIST FOR MPLAN25-15-3-0130

Key	Part No.	Descriptions	Q'ty	
1	171398-000	DUST HOOD	1	
2	000801-101	ROUND HEAD HEX SCREW	M6*1.0P*10	57
3	171393-000	CHIP BRACKER		1
4	000104-110	SOC HD CAP SCREW	M8*1.25P*30	4
5	006305-100	SPRING WASHER	8.2*15.4	23
6	050320-000	BRACKET		4
7	008006-100	HEX NUT	M8*1.25P	15
8	171559-000	TOP COVER		1
9	340007-615	BLOCK		2
10	250123-615	HANDLE		1
11	000104-108	SOC HD CAP SCREW	M8*1.25P*25	8
12	006001-022	FLAT WASHER	6.3*13*1.0t	23
13	000102-104	SOC HD CAP SCREW	M5*0.8P*12	4
14	006302-100	SPRING WASHER	5.1*9.3	8
15	170893-901	PACKING		2
16	170501-904	IDEL BRACKET		1
17	000105-104	SOC HD CAP SCREW	M10*1.5P*35	5
18	008004-100	HEX NUT	M5*0.8P	1
19	000104-106	SOC HD CAP SCREW	M8*1.25P*20	8
20	290040-901	IDLE FIXING SHAFT		1
21	380259-000	SPROCKET		6
22	006001-071	FLAT WASHER	10*25*3.0t	15
23	008007-100	HEX NUT	M10*1.5P	20
24	050580-000	LEFT SUPPORT PLATE		1
27	000103-106	SOC HD CAP SCREW	M6*1.0P*16	6
28	008005-100	HEX NUT	M6*1.0P	7
29	250054-615	KNOB		1
30	360414-910	HANDEL SHAFT		1
36	170895-000	LEFT SIDE COVER		1
37	173211-000	SIDE COVER - LEFT		1
39	000203-109	SET SCREW	M6*1.0P*30	6
40	170510-000	DUST CHUTE		1
41	000001-103	HEX. SCREW	M5*0.8P*25	1
42	170957-902	ADJUST BOLCK		6
43	130047-903	BUSHING		6
44	360196-000	OUTFEED ROLLER		1

Key	Part No.	Descriptions		Q'ty
45	012003-003	KEY	5*5*12	5
46	170002-901	WASHER		3
47	000105-101	SOC HD CAP SCREW	M10*1.5P*20	11
48	000105-109	SOC HD CAP SCREW	M10*1.5P*75	2
49	280056-901	COMPRESSED SPRING		2
50	000105-105	SOC HD CAP SCREW	M10*1.5P*40	3
51	050455-000	PRESSURE PLATE - REAR		1
52	070019-902	SPROCKET		2
54	360189-000	OUTFEED ROLLER		1
55	030202-000	BALL BEARING	6007-2NSE	2
56	030219-000	BALL BEARING	6210-2NSE	2
57	012005-003	KEY	8*7*35	2
58	922090-000	SHEARTEC 2 CUTTERHEAD ASSY		1
58.1	922088-001	SHEARTEC 2 CUTTERHEAD ASSY		1
58.2	921955-000	KNIFE	15*15*2.5t	10
58.3	038201-101	TORX SCREW	#10-32NF*1/2"	10
	040702-000	TORX SCREW DRIVER	CR-V T-25	2
59	006701-100	WAVE WASHER	WW-6	1
60	002603-101	CAP LOCKING SCREW	M5*0.8P*10	2
61	250352-615	RUBBER PIN		144
62	290055-901	SHOULDER SCREW		1
64	000104-111	CAP SCREW	M8*1.25P*35	4
65	006001-084	FLAT WASHER	11*53*3.0t	1
66	050464-902	CUTTERHEAD PULLEY		1
67	190151-902	BUSHING		1
68	006307-100	SPRING WASHER	10.2*18.5	20
69	000204-102	SET SCREW	M8*1.25P*10	14
70	006712-100	WAVE WASHER	BWW-6001	1
71	006001-056	FLAT WASHER	8.5*23*2.0t	6
72	050881-000	CUTTERHEAD BASE - LEFT		1
73	360624-902	FIXING SHAFT		2
74	360629-902	PRESSURE PLATE SHAFT		2
75	010011-000	RETAINING RING	STW-25	3
76	380470-902	COLLER		2
77	012005-006	KEY	8*7*16	1
78	360506-000	FIXING SHAFT		1
79	190051-902	LIMITED SHAFT		1
80	130052-903	INFEED ROLLER		24

Key	Part No.	Descriptions	Q'ty	
81	050880-000	CUTTERHEAD BASE - RIGHT	1	
82	170512-901	PACKING	12	
83	360408-902	FIXING SHAFT	6	
84	280055-901	SPRING	6	
85	050462-000	PRESSURE PLATE BASE - LEFT	1	
86	011106-102	PIN	8*30	4
87	050305-000	PRESSURE PLATE - FRONT	11	
88	280053-000	SPRING	11	
89	050463-000	PRESSURE PLATE BASE - RIGHT	1	
90	360627-902	FIXING SHAFT	2	
91	360632-902	FIXING SHAFT	2	
92	250160-615	SPACER	79	
93	172281-905	ANTI-KICK BACK	70	
94	010107-000	RETAINING RING	RTW-47	6
95	380388-902	HEX SCREW	1	
96	000102-103	SOC HD CAP SCREW	M5*0.8P*10	2
97	000302-210	ROUND HD SCREW	M4*0.7P*30	6
98	000301-204	ROUND HD SCREW	M5*0.8P*15	2
100	021002-000	CABLE TIE	250M	2
101	050575-000	RIGHT SUPPORT PLATE	1	
102	000302-103	ROUND HD SCREW	M4*0.7P*10	8
103	002501-102	ROUND HEAD TAPPING SCREW	M6*1.0P*12L	8
103	002501-102	ROUND HEAD TAPPING SCREW	M6*1.0P*12L	11
104	171561-000	SIDE COVER - RIGHT	1	
105	171401-000	RIGHT SIDE COVER	1	
106	016001-000	CHAIN	#40*24P	1
107	923250-000	GEAR BOX ASSY	1	
107.1	000105-101	SOC HD CAP SCREW	M10*1.5P*20	5
107.2	006001-071	FLAT WASHER	10*25*3.0t	1
107.3	923207-000	BELT PULLEY ASSY	1	
107.4	000104-106	SOC HD CAP SCREW	M8*1.25P*20	1
107.5	006001-056	FLAT WASHER	8.5*23*2.0t	1
107.6	150014-000	SPROCKET	1	
107.7	011106-101	PIN	8*18	2
107.8	050467-008	GEAR BOX COVER	1	
107.9	340050-000	GEARBOX GASKET	1	
107.10	012003-005	KEY	5*5*16	1
107.11	012003-002	KEY	5*5*10	3

Key	Part No.	Descriptions		Q'ty
107.12	043605-000	OIL SEAL	TC24*40*7	1
107.13	030208-000	BALL BEARING	6204-2NSE	2
107.14	320208-000	GEAR		2
107.15	010007-000	RETAINING RING	STW-16	3
107.16	030205-000	BALL BEARING	6201-2NSE	6
107.17	043603-000	OIL SEAL	TC20*40*7	1
107.18	010011-000	RETAINING RING	STW-25	1
107.19	381082-000	PLUG		1
107.20	361005-000	SHAFT		1
107.21	320316-000	GEAR		1
107.22	360646-000	SHAFT		1
107.23	320209-000	GEAR	60T	2
107.24	012003-007	KEY	5*5*20	2
107.25	360647-000	GEAR SHAFT		1
107.26	043001-000	OIL LENS	29	1
107.27	381073-000	BUSHING		1
107.28	360648-000	GEAR SHAFT		1
107.29	050466-000	GEARBOX		1
107.30	320211-000	GEAR	24T	1
107.31	043401-000	PLUG	PT1/4"-19	2
107.32	012003-001	KEY	5*5*8	1
108	050774-000	TABLE		1
109	006001-075	FLAT WASHER	10.3*22*2.0t	14
110	290024-901	SHOULDER SCREW		4
111	001903-104	SET LOCK SCREW	M8*1.25P*10	1
112	000102-105	SOC HD CAP SCREW	M5*0.8P*16	6
113	171818-902	LEAD PLATE		2
114	170498-901	PLATE		2
115	000204-109	SET SCREW	M8*1.25P*40	6
116	000004-103	HEX. SCREW	M10*1.5P*30	4
117	130049-903	ROLLER FIXING BASE		4
118	030207-000	BALL BEARING	6203-2NSE	6
119	920669-000	ROLLER W/BEARING		2
120	006001-049	FLAT WASHER	8.5*16*2.0t	8
121	360419-901	CAM LOCK SHAFT		4
122	130050-000	CAM LOCK		4
123	023301-000	FIXING PLATE	AAM-20	2
124	360636-902	KNIFE SETTING GAGE SHAFT		2

Key	Part No.	Descriptions		Q'ty
125	000202-102	SET SCREW	M5*0.8P*8	6
126	130048-903	CONNECT PLATE		3
127	290016-901	SHOULDER SCREW		2
128	170900-902	ROD		1
129	012003-002	KEY	5*5*10	8
130	010501-000	RETAINING RING	ISTW-30	6
131	040003-000	HEX. WRENCH	3mm	1
132	171396-156	POINTER BRACKET		1
133	170899-902	ROD		1
134	360420-902	FIXING SHAFT		1
135	010211-000	RETAINING RING	ETW-24	1
138	050313-902	BRACKET		1
139	000203-102	SET SCREW	M6*1.0P*8	1
140	230122-000	UNIVERSAL HANDLE		1
141	050318-902	FIXING SHAFT		2
142	000104-112	SOC HD CAP SCREW	M8*1.25P*40	8
143	900487-000	MOTOR ASSY	1/2HP*230V/460V*60HZ*3PH	1
144	000003-105	HEX. SCREW	M8*1.25P*25	4
145	000103-107	SOC HD CAP SCREW	M6*1.0P*20	1
146	006303-100	SPRING WASHER	6.1*12.3	21
146	006303-100	SPRING WASHER	6.1*12.3	8
147	290015-901	SHOULDER SCREW		1
148	030116-000	BALL BEARING	6205ZZ	2
149	360642-000	WROM SHAFT		1
150	012003-008	KEY	5*5*22	1
151	320248-000	WORM GEAR		1
152	190085-901	BUSHING		1
153	030109-000	BALL BEARING	6204ZZ	1
154	050461-008	WORM GEARBOX		1
155	043607-000	OIL SEAL	TC25*40*8	1
156	360641-000	WORM ROD		1
157	320247-000	GEAR	24T	1
158	030108-000	BALL BEARING	6203ZZ	2
159	040004-000	HEX. WRENCH	4mm	1
160	050574-008	IDEL BRACKET		1
161	030106-000	BALL BEARING	6201ZZ	1
162	010007-000	RETAINING RING	STW-16	3
163	320209-000	GEAR	60T	2

Key	Part No.	Descriptions	Q'ty
164	360640-000	SHAFT	1
165	043501-000	OIL SEAL	SC17*30*8
166	010008-000	RETAINING RING	STW-17
167	340049-000	GEARBOX GASKET	1
168	050459-008	GEAR BOX COVER	1
169	000103-108	SOC HD CAP SCREW	M6*1.0P*25
170	011104-105	PIN	6.0*25
171	320245-000	SPROCKET	26T
172	043401-000	PLUG	PT1/4"-19
173	030107-000	BALL BEARING	6202ZZ
174	360643-000	GEAR SHAFT	1
175	012003-007	KEY	5*5*20
176	320208-000	GEAR	1
177	006001-101	FLAT WASHER	16*25*1.5t
178	016009-000	CHAIN	#40*58P
179	320310-902	SPROCKET	1
180	920372-000	HANDWHEEL ASSY	1
181	050458-902	HANDWHEEL BASE	1
182	923453-000	MOTOR CORD	3PH
183	012003-004	KEY	5*5*15
184	360631-000	HANDWHEEL SHAFT	1
185	280091-000	SPRING	1
186	000104-103	SOC HD CAP SCREW	M8*1.25P*12
187	000203-106	SET SCREW	M6*1.0P*16
188	380226-902	BUSHING	1
189	011106-101	PIN	8*18
190	000103-102	SOC HD CAP SCREW	M6*1.0P*10
191	006001-021	FLAT WASHER	6.2*22*3t
192	900328-001	MOTOR ASSY	15HP*230V/460V*60HZ*3PH
193	032101-000	NEEDLE BEARING	NA-6906
194	360155-902	IDLE FIXING SHAFT	1
195	010108-000	RETAINING RING	RTW-52
196	000004-306	HEX. SCREW	M10*1.5P*50
197	008009-100	HEX NUT	M12*1.75P
198	006308-100	SPRING WASHER	12.2*21.6
199	006001-091	FLAT WASHER	13*28*3.0t
200	380249-901	MOTOR MOUNT TENSION SHAFT ASSEMBLY	2

Key	Part No.	Descriptions		Q'ty
201	050368-008	MOTOR PLATE		1
202	360270-902	MOTOR MOUNTING SHAFT		2
204	360634-000	SHAFT		1
205	170481-901	FIXING BUSH		4
206	001601-101	POUND HEAD SCREW W/FLAT WASHER	M4*0.7P*8/4*10*0.8t	8
207	250173-615	EXPANSION BEND		2
208	360423-000	SHAFT		1
209	010110-000	RETAINING RING	RTW-68	2
210	030203-000	BALL BEARING	6008-2NSE	2
211	031003-000	BEARING	51105	4
212	050662-902	BUSHING		2
213	006802-100	WASHER	25	2
214	008201-100	NUT	M25*1.5P	2
215	190084-902	PACKING		1
216	014106-000	V-BELT	A81	3
217	015201-000	BELT	3GT-750-15	1
218	070017-000	SPROCKET	26T	1
219	280067-901	SPRING		1
220	172297-000	COVER - REAR		1
221	021802-000	RELIEF BUSHING	NB-2430	2
222	021805-000	RELIEF BUSHING	NB-1216	2
223	170894-000	WIRING BOARD		1
224	008308-100	HEX LOCK NUT	M10*1.5P	4
225	170638-156	HOOK		4
226	000105-103	SOC HD CAP SCREW	M10*1.5P*30	14
227	000006-206	HEX. SCREW	M16*2.0P*55L	4
228	008011-200	HEX NUT	M16*2.0P	5
229	050314-008	FOOT		4
230	173210-000	BASE		1
231	360693-902	IDEL SHAFT		1
232	172728-000	COVER - FRONT		1
233	170892-000	COVER - SIDE		2
234	006001-083	FLAT WASHER	11*37*3.0t	2
235	001302-101	CAP SCREW	M10*1.5P*20	1
236	000105-112	SOC HD CAP SCREW	M10*1.5P*45	2
237	016010-000	CHAIN	#40*74P	1
238	008306-100	HEX LOCK NUT	M8*1.25P	4
239	230276-000	BUFFER	25kg	2

Key	Part No.	Descriptions		Q'ty
240	016002-000	CHAIN	#40*54P	1
241	016012-000	CHAIN	#40*84P	1
242	006003-079	FLAT WASHER	10.5*19*2.0t	2
243	006001-003	FLAT WASHER	4.3*12*1.0t	6
245	000203-107	SET SCREW	M6*1.0P*20	1
246	937680-000	CONTROL BOX ASSEMBLY	15HP*3PH	
247	000103-103	SOC HD CAP SCREW	M6*1.0P*12	4
249	000106-102	SOC HD CAP SCREW	M12*1.75P*40	12
250	280098-000	SPRING		1
251	490126-000	CONNECTION BOX		1
252	490127-000	TERMINAL		1
253	000303-103	ROUND HD SCREW	M5*0.8P*10	4
254	550001-288	MANUAL FOR CONTRAL PANEL		1
256	006001-034	FLAT WASHER	6.7*16*2.0t	4
257	000004-107	HEX. SCREW	M10*1.5P*70	2
258	001301-101	CAP SCREW	M8*1.25P*20	1
259	290009-902	SHOULDER SCREW		2
260	190002-905	FIXING POINT		2
261	921336-000	POWER CORD	3PH	1
263	190074-901	SPACER		2
264	010205-000	RETAINING RING	ETW-8	2
265	171399-902	BRACKET		1
266	921133-000	INDUCTION PLATE		1
267	150001-000	IDLE		2
268	000105-107	SOC HD CAP SCREW	M10*1.5P*50	4
275	040005-000	HEX. WRENCH	5mm	1
276	040007-000	HEX. WRENCH	8mm	1
277	040204-000	WRENCH BOX	12*14	1
278	040206-000	WRENCH BOX	17*19	1
279	040207-000	WRENCH BOX	22*24	1
280	040401-000	SCREW DRIVER		1
283	000201-101	SET SCREW	M4*0.7P*6	1
285	920664-000	ADJUST KNOB		2
287	171151-902	FIX PLATE		2
288	200032-615	SPONGE-LONG	40*10*2t	1
289	200033-615	SPONGE-SHORT	33*10*2t	1
290	002201-201	WOOD SCREW	M6*2.6P*24	24
291	010118-000	RETAINING RING	RTW-90	1

Key	Part No.	Descriptions		Q'ty
292	010109-000	RETAINING RING	RTW-62	1
293	380787-902	SPACER		1
294	002602-102	CAP LOCKING SCREW	M6*1.0P*20	12
296	006001-023	FLAT WASHER	6.3*13*2.0t	12
297	000003-110	HEX. SCREW	M8*1.25P*50	1
298	006001-046	FLAT WASHER	8.5*16*1.5t	1
299	000202-101	SET SCREW	M5*0.8P*5	1
300	300052-000	PULLEY		1
301	050775-150	EXTENSION ROLLER ASSEMBLY		2
302	000005-102	HEX. SCREW	M12*1.75P*50	6
303	000205-103	SET SCREW	M10*1.5P*20	6
304	021335-000	RELIEF BUSHING	MG20A-14B	1
305	490508-000	SWITCH	10AMP	1
306	922316-000	HANDWHEEL ASSY		1
307	001904-102	SET LOCK SCREW	M4*0.7P*4	1
308	173213-000	BRACKET		1
309	000003-218	HEX. SCREW	M8*1.25P*90	1
310	000302-102	ROUND HD SCREW	M4*0.7P*8	1
311	021112-000	CABLE FASTENER	ACC-3	1
312	173377-000	COVER PLATE		1

LAGUNA

2072 Alton Parkway. Irvine, CA 92606
Ph: 800.234.1976 | www.lagunatools.com

Laguna Tools is not responsible for errors or omissions.
Specifications subject to change. Machines may be shown with optional accessories.

© 2015, Laguna Tools, Inc. LAGUNA® and the LAGUNA Logo® are the
registered trademarks of Laguna Tools, Inc. All rights reserved.