



INDUSTRIAL IN-LINE ROUTER TABLE

OWNER'S MANUAL

MODEL RT-TGI



Copyright SawStop, LLC
All Rights Reserved

1st printing, January 2018

Updates of this manual may be
available at www.sawstop.com

The saw shown on the front cover is the Industrial Cabinet Saw, Model ICS with Industrial Mobile Base. Your saw may look different.

The ICS In-Line Router Table Assembly shown on the front cover includes the Stock Guide for Router Table Fence (RT-STP). This is an optional accessory that does not come included with your ICS In-Line Router Table Assembly. The Four-Post Router Lift with Lock and Downdraft Dust Collection Box for Router Lift are also shown installed on the ICS In-Line Router Table Assembly. The Four-Post Router Lift with Lock and Downdraft Dust Collection Box for Router Lift are not included with your ICS In-Line Router Table Assembly and your setup may look different.

SawStop, the SawStop blade logo, and the configuration of this product are either registered trademarks or trademarks of SawStop, LLC. Software copyright by SawStop, LLC. All rights reserved.

TO OUR CUSTOMERS

Thank you for purchasing the SawStop ICS In-Line Router Table Assembly. We are confident you will be pleased with the quality and performance.

This manual tells you more about your ICS In-Line Router Table Assembly and how to operate and maintain it. Please read the manual carefully. The manual also includes our warranty and important safety information.

If you ever have any questions or comments, feel free to contact us at the address below.

SawStop, LLC
11555 SW Myslony Street | Tualatin, Oregon 97062 USA

Phone: (503) 570-3200

Fax: (503) 570-3303

Email: info@sawstop.com

www.sawstop.com

HOW TO GET HELP

Missing Parts? Have Questions?

Our technical support team is standing by
M-F, 6:30am-5pm PST
to help with whatever you need.



Give us a call at
503.582.9934



Email us at
SERVICE@SAWSTOP.COM



TABLE OF CONTENTS

Assembly Options.....	1
Before You Begin.....	4
Product Specifications.....	5
Parts Inventory.....	6
Cast Iron Table Parts and Hardware.....	6
Support Legs Parts and Hardware.....	7
Power Switch Parts and Hardware.....	8
Fence Assembly Parts and Hardware.....	9
Assembly & Installation.....	11
Assembling the Cast Iron Table.....	11
Hold-Down Strap Installation.....	12
Assembling and Installing the Support Legs and Power Switch.....	16
In-Line Installation Left of Left Wing.....	20
Rail Requirements: In-Line Right of ICS Right Wing.....	22
In-Line Installation Right: Between 36” Rails.....	23
In-Line Installation Right: Between 52” Rails.....	25
Assembling the Fence Assembly.....	31
Reference.....	36
Warranty.....	36
Safety.....	37
Warnings.....	37
Exploded View 1: Cast Iron Table (RT-C30)	39
Parts List 1: Cast Iron Table (RT-C30).....	40
Exploded View 2: Support Legs (RT-ST2).....	41
Parts List 2: Support Legs (RT-ST2).....	42
Exploded View 3: Power Switch (RT-PSW).....	43
Parts List 3: Power Switch (RT-PSW).....	44
Exploded View 4: 32” Fence Assembly (RT-F32).....	45
Parts List 4: 32” Fence Assembly (RT-F32).....	46
Available Accessories.....	47

The 30" x 16" Cast Iron Router Table with 32" Fence Assembly can be mounted to your SawStop Industrial Cabinet Saw (ICS) with T-Glide Fence System-Industrial Series II (TGI2) rails in any of three different configurations depending on your needs.



The between-rail installation of the 30" x 16" router table is only compatible with T-Glide Fence System – Industrial Series II (TGI 2) rails. If you wish to use the T-Glide Fence System – Industrial Series (CBFR) rails, you will have to modify them significantly.

In-Line Left of Left Wing

Option 1 of 3

This configuration increases the available table space of your SawStop table saw and provides the maximum ripping capacity to the left of the saw blade.

Required Components:

- 30" x 16" Cast Iron Router Table (RT-C30)
- Power Switch (RT-PSW)
- Support Legs (RT-ST2)

Compatible With:

- T-Glide Fence System – Industrial Series I or II (CBFR or TGI2) rails

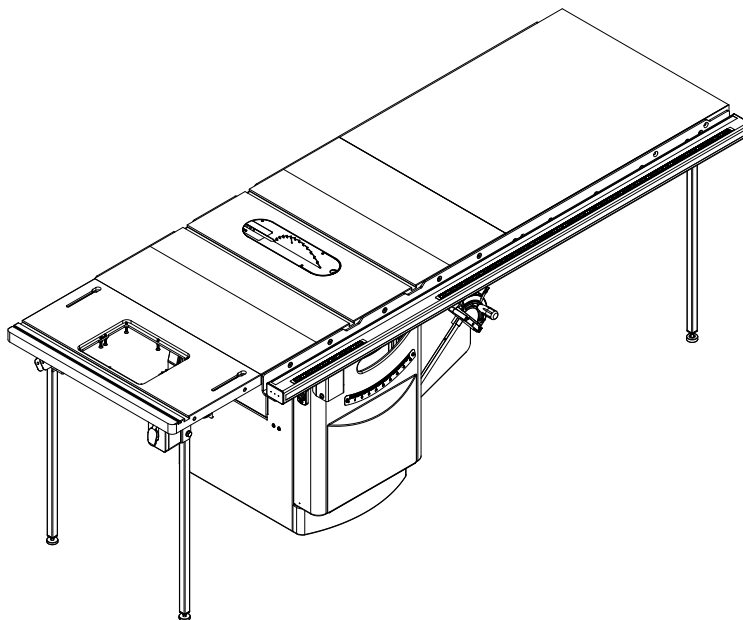

This configuration minimizes the total footprint of your SawStop table saw and router table. Users may choose to build an intermediate table to fill the gap between the right extension wing and the router table (no intermediate table for this configuration is offered by SawStop). The gap in the table measures 210mm wide.

Required Components:

- 30" x 16" Cast Iron Router Table (RT-C30)
- Power Switch (RT-PSW)
- Support Legs (RT-ST2)

Compatible With:

- T-Glide Fence System – Industrial Series II (TGI2) 36" Rails

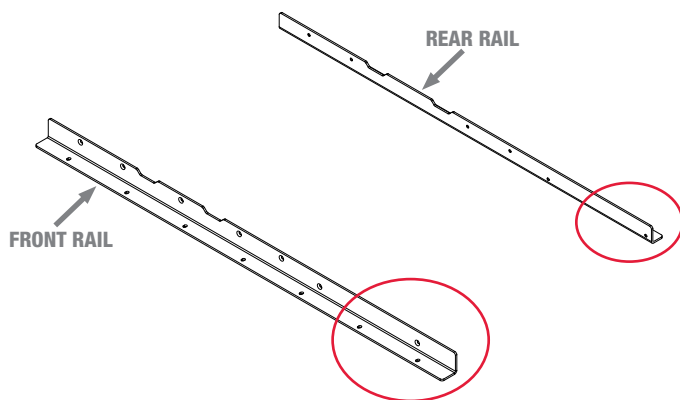
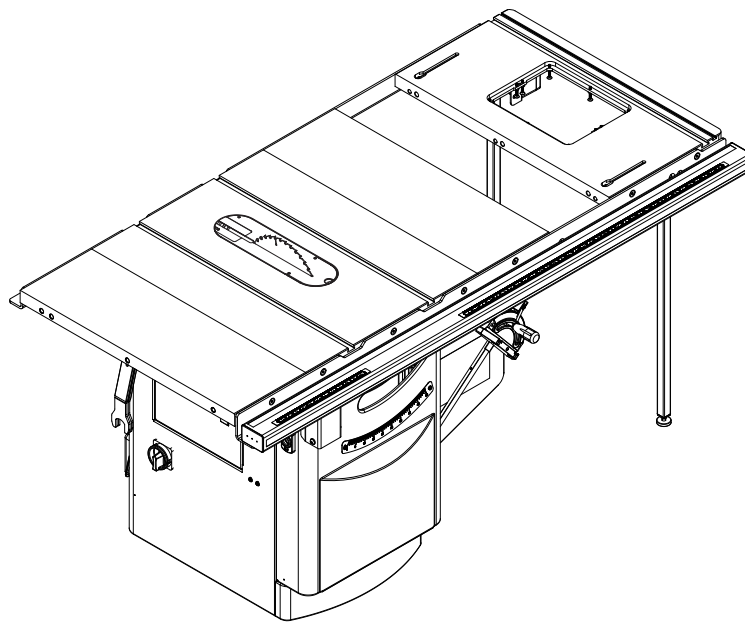

36" CBF105 3600 Rails
NOT COMPATIBLE
(Unless user modifies rails)

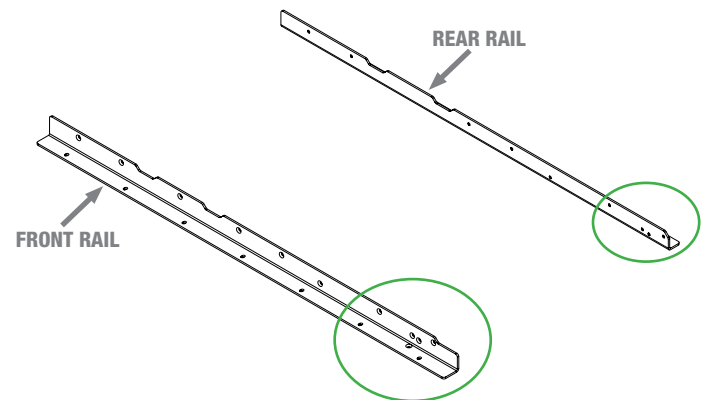

36" TGI2 Rails
COMPATIBLE

Refer to page 22 for more information on rail requirements.

This configuration maximizes the utility of the existing 52" rip capacity footprint.

Required Components:

- 30" x 16" Cast Iron Router Table (RT-C30)
- Power Switch (RT-PSW)
- Support Legs (RT-ST2) (Also included with 36" Extension Table)

Compatible With:

- T-Glide Fence System – Industrial Series II (TGI2) 52" Rails
- **36" Extension Table** (CBFT105 3600) (*NOT 52" Extension Table*)

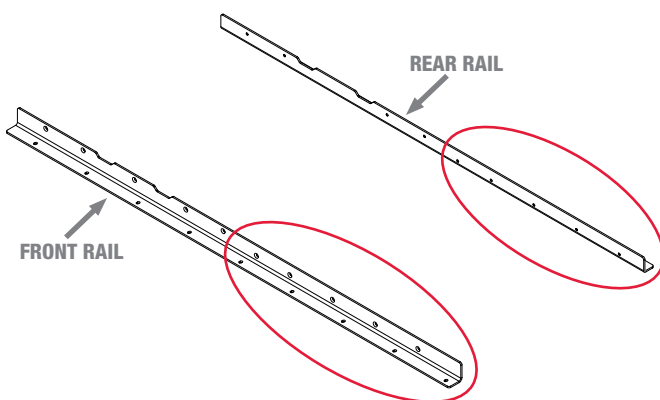
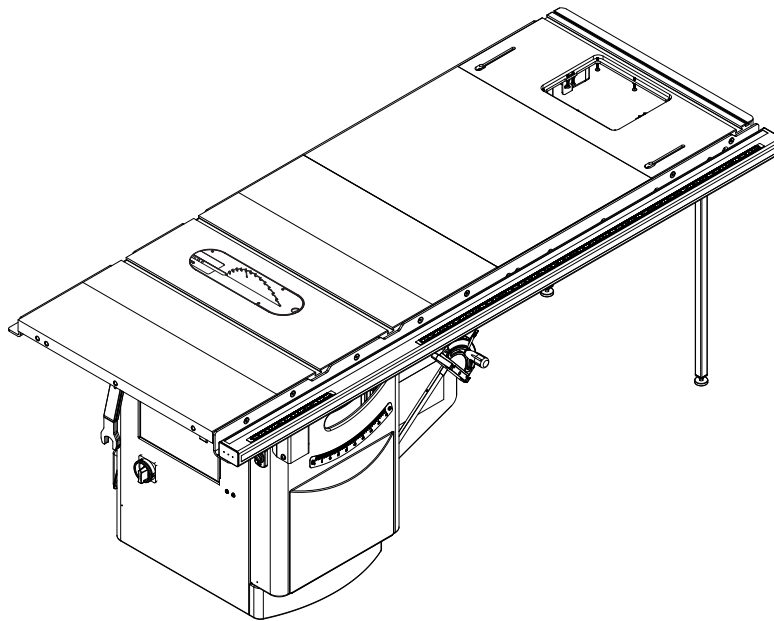

52" CBF104 5200 Rails
NOT COMPATIBLE
(Unless user modifies rails)

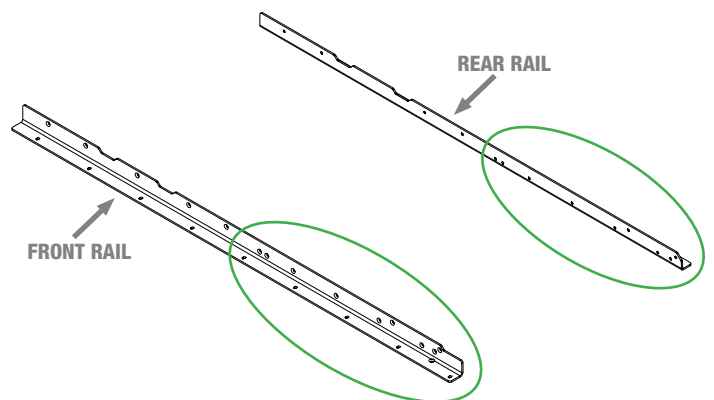

52" TGI2 Rails
COMPATIBLE

Refer to page 22 for more information on rail requirements.

BEFORE YOU BEGIN

Before mounting the Cast Iron Router Table, you may need to replace or modify your rails or other saw components. See Page 2 for compatibility notes.

Some of the steps involve removing/installing your rails and/or extension wings. For those steps, please refer to your table saw manual and table saw fence manual. (Download copies of your manuals at www.sawstop.com.)



DISCONNECT YOUR TABLE SAW FROM ELECTRICAL POWER BEFORE BEGINNING ANY MODIFICATIONS.

For Unassembled Saws:

If your saw has not yet been assembled, begin by installing and aligning the right and left extension wings as described in the installation documentation for your table saw. Then, install the RT-compatible front and rear rails as described in your table saw fence manual, but **do not install the tube or tighten the hardware.**

PRODUCT SPECIFICATIONS

30" x 16" Cast Iron Router Table	
Cast Iron Table	30" x 16"
Maximum Fence Travel	5 1/2"
Front T-slot to Arbor Center	6 1/2"
Width of Front T-slot	1/2" at top, 3/8" at bottom
Width of Rear T-slot	1" at top, 3/4" at bottom
Rear T-slot to Arbor Center	5"

32" Fence Assembly for Router Tables	
Length	56 1/2"
Height	3 1/2"
Depth	4"

Please unpack the parts carefully and confirm you have received each item on the list below.



IF YOU CANNOT FIND AN ITEM ON THIS LIST, CHECK THE MOUNTING LOCATIONS OR EXAMINE THE PACKAGING MATERIALS VERY CAREFULLY. CERTAIN COMPONENTS MAY HAVE BEEN PRE-INSTALLED FOR SHIPPING PURPOSES.

30" x 16" Cast Iron Router Table (RT-C30)

- A.** 30" x 16" Cast Iron Router Table (1)
- B.** M6 x 1.0 Hex Nut (10)
- C.** M6 x 1.0 x 40 Flat Head Phillips Screw (10)
- D.** Mobile Base Cabinet Hold-Down Kit for Router Tables (1)

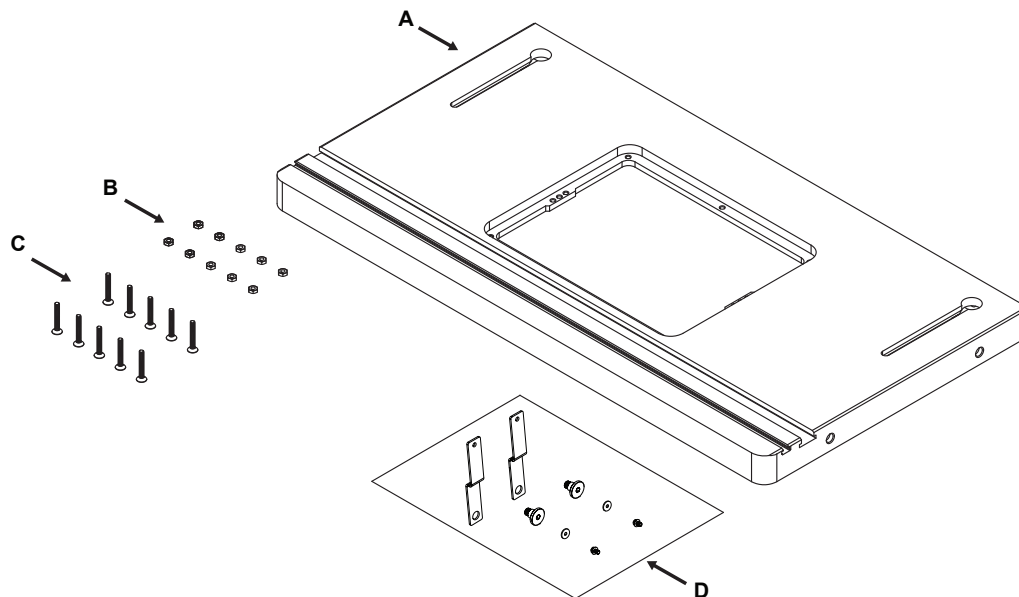

You will also need the following tools:

- Phillips Head Screwdriver

See Exploded View #1 on page 39 for more information.

Support Legs for In-Line Router Tables (RT-ST2)

- A.** Support Leg (2)
- B.** M8 x 1.25 Hex Nut (2)
- C.** Foot (2)

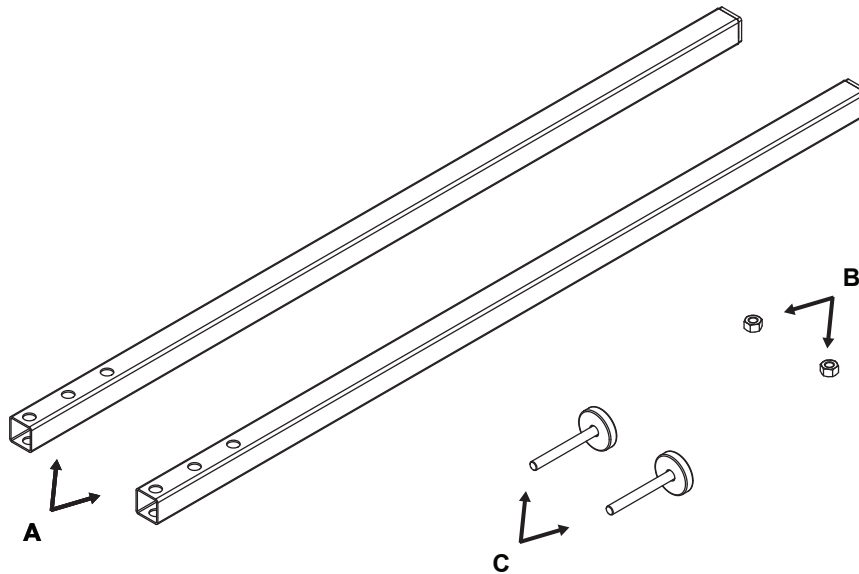

You will also need the following tools to complete the Support Legs:

- 13mm Wrench

See Exploded View #2 on page 41 for more information.

Power Switch for In-Line Router Tables (RT-PSW)

A. In-Line Switch Box Mounting Bracket Assembly (1)

B. Handle Mounting Bracket (1)

C. Leg Mounting Bracket (1)

D. Leg Mounting Hardware Pack (1)

- M10 x 1.5 x 45 Hex Head Bolt (4)
- M10 x 19 x 2 Washer (8)
- M10 x 1.5 Lock Nut (4)
- M6 Lock Washer (4)
- M6 x 1.0 x 12 Socket Head Cap Screw (4)
- M5 x 0.8 x 30 Pan Head Phillips Screw (1)
- M5 Lock Washer (2)
- M5 x 12 x 1 Washer (2)
- M5 x 0.8 x 8 Pan Head Phillips Screw (1)

E. Wing Mounting Hardware Pack (1)

- M8 x 1.25 x 45 Hex Head Bolt (4)
- M8 x 19 x 2 Washer (8)
- M8 Lock Washer (4)
- M8 x 1.25 x 12 Hex Nut (4)

F. Rail Mounting Hardware Pack (1)

- M8 x 1.25 x 25 Flat Head Socket Screw (4)
- M8 x 19 x 2 Washer (4)
- M8 Lock Washer (4)
- M8 x 1.25 x 12 Hex Nut (4)

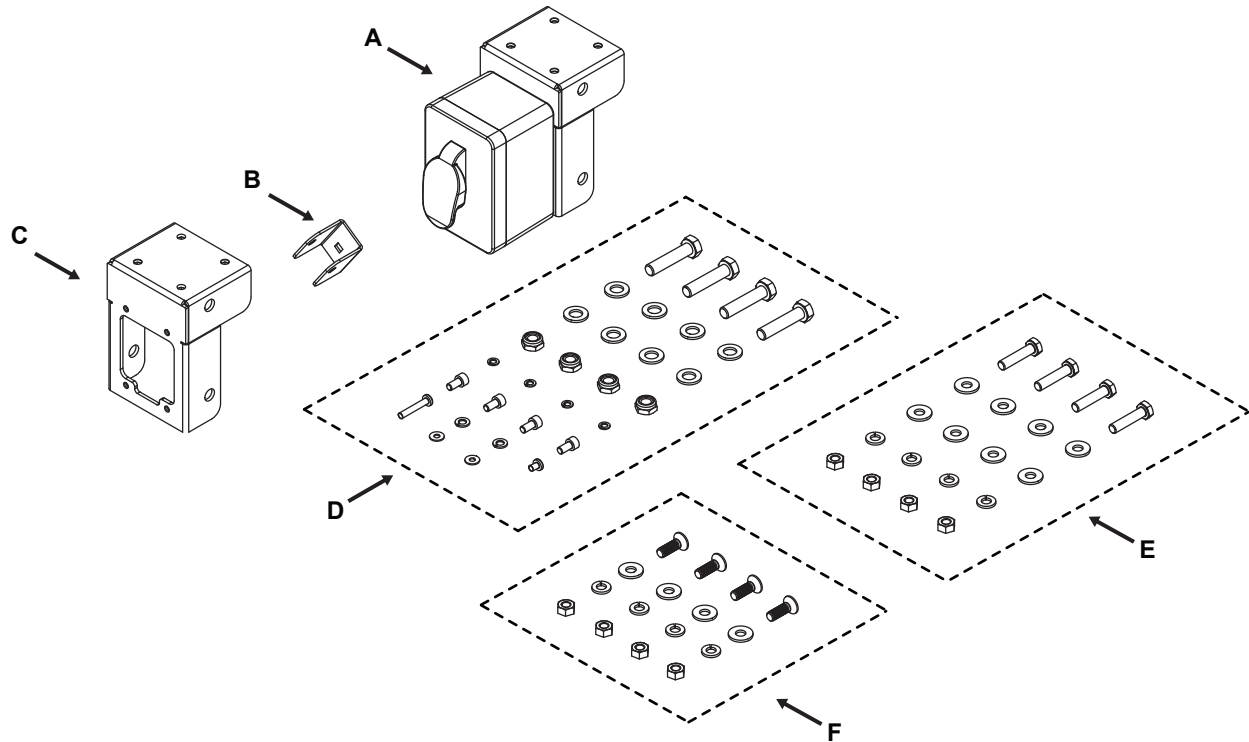

You will also need the following tools to complete the Power Switch:

- Phillips Head Screwdriver
- 16mm Wrench (x2)
- 13mm Wrench (x2)
- 5mm Hex Wrench
- Level or Straight Edge

See Exploded View #3 on page 43 for more information.

32" Fence Assembly for Router Tables (RT-F32)

- A.** 32" Router Table Fence (1)
- B.** Fence Lock Knob (2)
- C.** M8 x 23 x 2 Washer (2)
- D.** 23mm Lock Knob Nut (2)
- E.** Fence Face Plate Lock Knob (8)
- F.** M6 x 16 x 2 Washer (14)
- G.** M6 x 1.0 x 35 T-Bolt (8)
- H.** 2 1/2" Dust Port (1)
- I.** 1/4"-20 x 3/4" Pan Head Phillips Screw (2)
- J.** 1/4"-20 Square Nut (8)
- K.** Face Plate Space Bar (2)
- L.** Router Fence Face Plate (2)
- M.** Router Fence Guard (1)
- N.** Router Fence Guard Spacer (2)
- O.** 32" Table Rail with Ruler and Lock Knob (2)
- P.** Rail Mounting Bracket (2)
- Q.** 1/4"-20 x 5/8" Hex Head Bolt (6)
- R.** M6 x 1.0 x 12 Socket Head Cap Screw (8)
- S.** 19mm Lock Knob Nut (2)

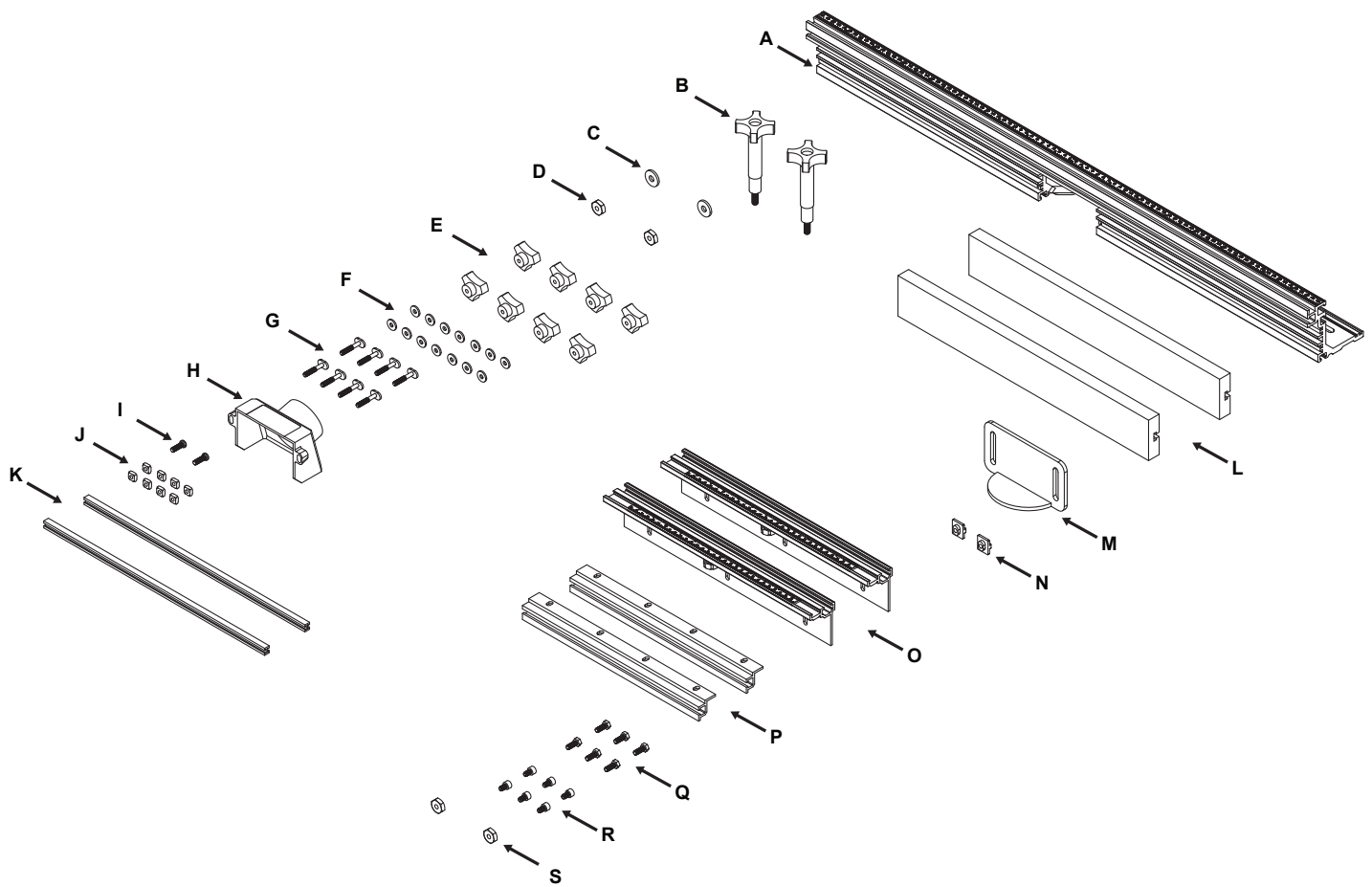

You will also need the following tools to complete the 32" Fence Assembly:

- Phillips Head Screwdriver

See Exploded View #4 on page 45 for more information.



Important Part Identification Note:

Throughout the manual, the exploded views are referenced to clarify the location and name of each part. **There are multiple exploded views in this manual, so a decimal point system is used.** The number before the decimal point refers to the exploded view number (in this case, 1 through 4). The number after the decimal point refers to the part number (as indicated by the number in the balloon in the exploded view). For example, a part referenced as “1.1” would be the part labeled with a “1” balloon in the exploded view #1.

- Exploded View #1: 30” x 16” Cast Iron Router Table – See page 39
- Exploded View #2: Support Legs for In-Line Router Tables – See page 41
- Exploded View #3: Power Switch for In-Line Router Tables – See page 43
- Exploded View #4: 32” Fence Assembly for Router Tables – See page 45

Assembling the 30" x 16" Cast Iron Router Table

Requires: 30" x 16" Cast Iron Router Table Hardware
Phillips Head Screwdriver

- 1 Remove the protective covering from the table (1.1) and wipe off the oil with a soft, clean cloth.

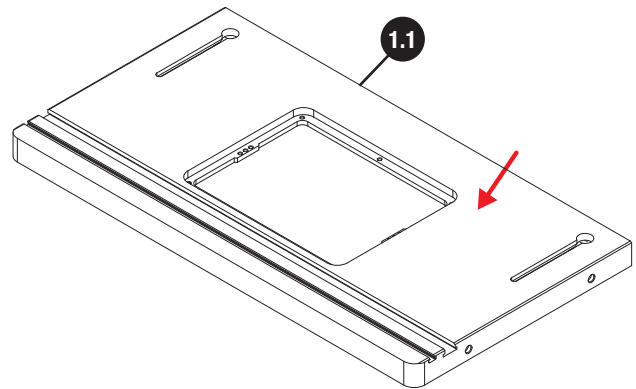

- 2 Thread ten M6 hex nuts (1.2) partway onto ten M6 flat head Phillips screws (1.3).

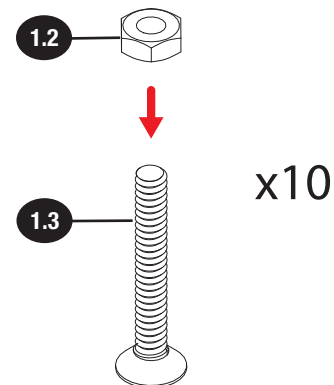

- 3 Place the router table (1.1) upside down on a flat surface and thread the M6 flat head Phillips screws (1.3) with prethreaded nuts into the threaded holes around the insert opening in the table until they extend about 1/4" below the table's top surface. These screws will support and level the router lift relative to the table top. The 2 holes in the center of the opening (shown in red) do not receive leveling screws; they will be used later to attach the router lift to the router table.

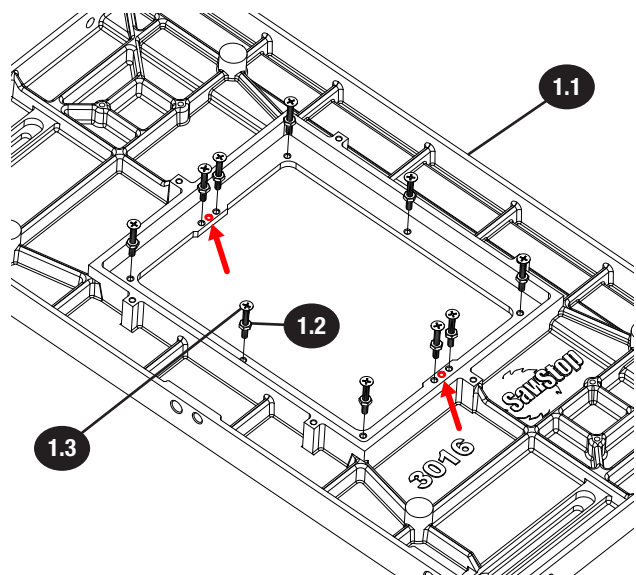

- 4 Finger tighten the hex nuts up against the bottom of the table. You will adjust the screws and fully tighten the hex nuts later, after you install your router lift.

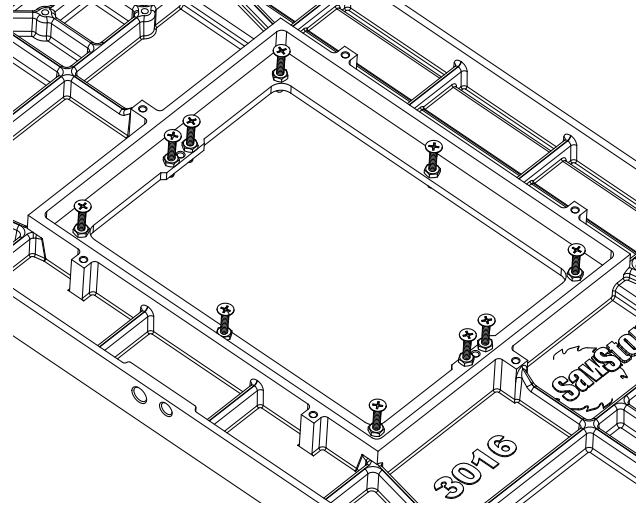

- 5 Your router table includes a Mobile Base Hold-Down Kit (1.5). These should be attached to your Industrial Mobile Base now to ensure stability. If your mobile base already has hold-down straps, the ones included with your router table can be discarded. Otherwise, please complete the following steps to install the hold-down straps. **If the hold-down straps are already installed, or you do not have a mobile base, proceed to page 16.**

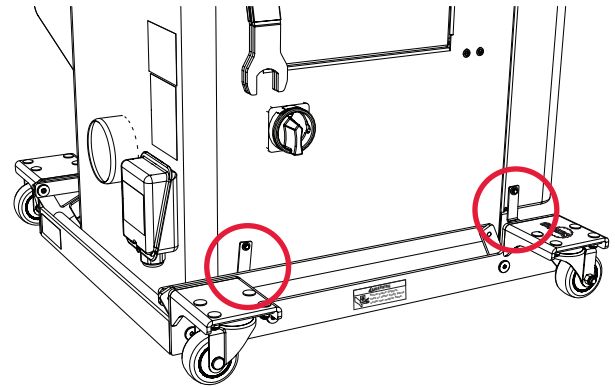

Hold-Down Strap Installation

If your saw already has the Industrial Mobile Base installed without the hold-down straps, you will need to remove the saw from the mobile base to install the hold-down straps before proceeding.

- 1 Unscrew the M8 x 1.25 x 18 shoulder socket screw at the front-left of the mobile base in the front support strap, as shown by the red arrow in the figure.

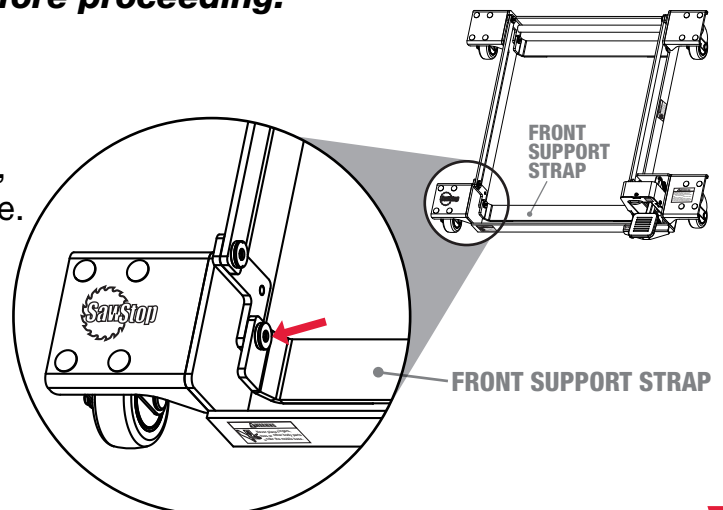

- 2 Unscrew the M8 x 1.25 x 18 shoulder socket screw at the rear-left of the mobile base in the rear support strap, as shown by the red arrow in the figure.

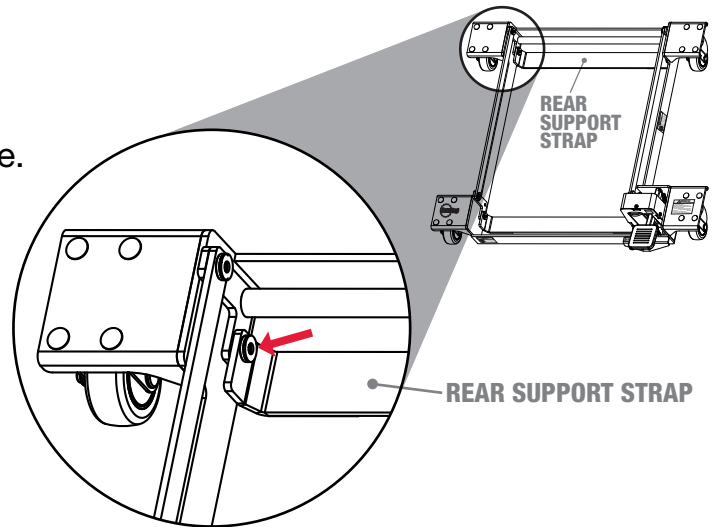

- 3 From the Mobile Base Cabinet Hold-Down Kit (located in the 30" x 16" Cast Iron Router Table box), thread the M8 x 1.25 x 18 shoulder socket screw through the larger hole of one of the hold-down straps and then back into the same hole in the rear support strap of the mobile base. Note the orientation of the hold-down bracket and ensure it matches the figure to the right so that it bends inward toward the center of the mobile base. Finger-tighten the screw.

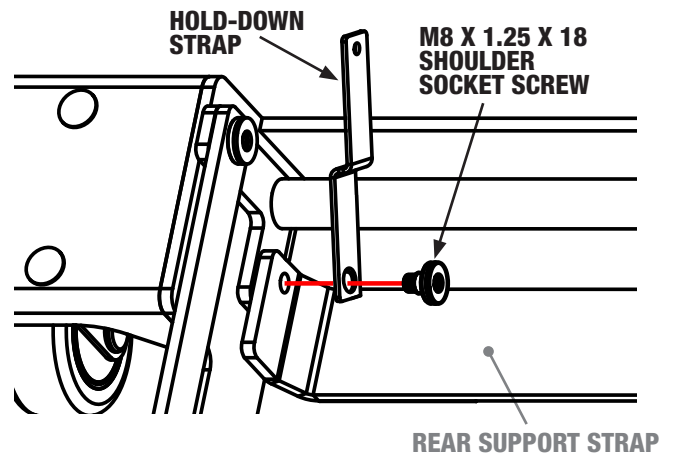

- 4 Repeat step 3 for the front hold-down strap, making sure the hold-down strap is in the correct orientation. Finger-tighten the screw.

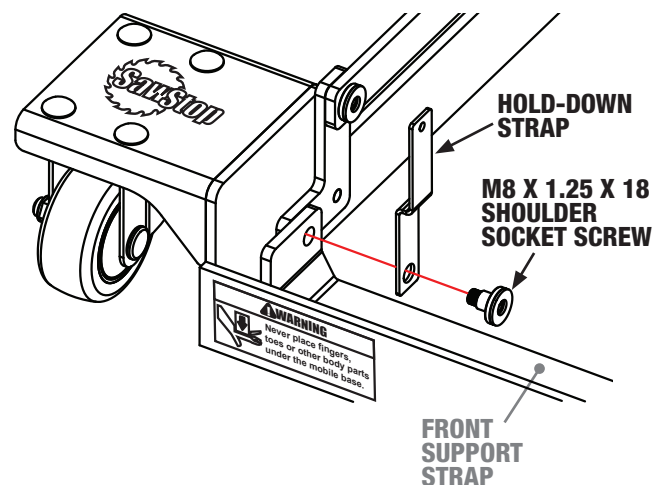

5 Fully tighten both screws using a 5mm hex key. The mobile base is now ready to place your saw into, but first - rotate the rear hold-down bracket back as far as possible and rotate the front hold-down bracket forward as far as possible.

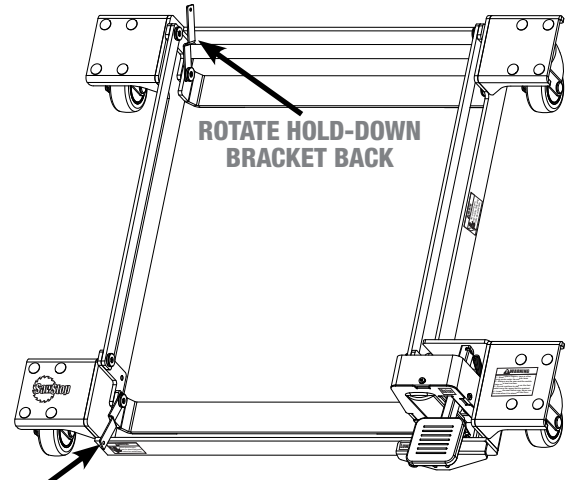

ROTATE HOLD-DOWN BRACKET FORWARD

6 To safely place the saw into the mobile base, you will need at least four people to lift the saw off the floor and then lower it onto the mobile base. Have one person lift each corner of the cast iron table top. If your saw has an extension table, have the two people on the right side of the saw lift on the extension rails near the outer corner of the cast iron extension wing, not at the end of the extension table. If a fifth person is available, it may be easier to have four people lift the saw and the fifth person slide the base under the saw.

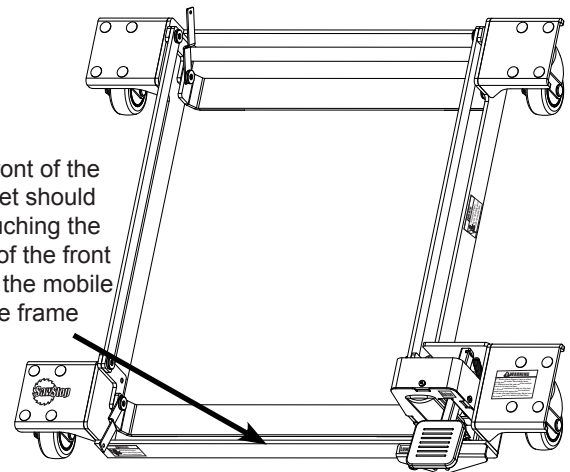

Make sure the mobile base is centered underneath the table saw and that the foot pedal is in the front. The saw should sit on the two “straps” on the interior of the mobile base, and the front of the cabinet should be touching the inside of the front face of the mobile base frame.

7 Locate the two self-tapping screws and the two M4 x 12 x 1 washers from the hold down kit. Some cabinet configurations will have pre-drilled holes for the self-tapping screws. If your saw cabinet does not have pre-drilled holes, or you are having difficulty aligning the holes, rotate the rear hold-down bracket until the top hole is over the flat face of the cabinet. Place one of the M4 x 12 x 1 washers over the end of one of the self-tapping screws and use a drill with a 1/4 inch hex drive bit to mount the rear hold-down bracket to the cabinet. There is no need to pre-drill a hole for the self-tapping screws, but be careful not to overtighten the screws or the threads in the cabinet may strip out.

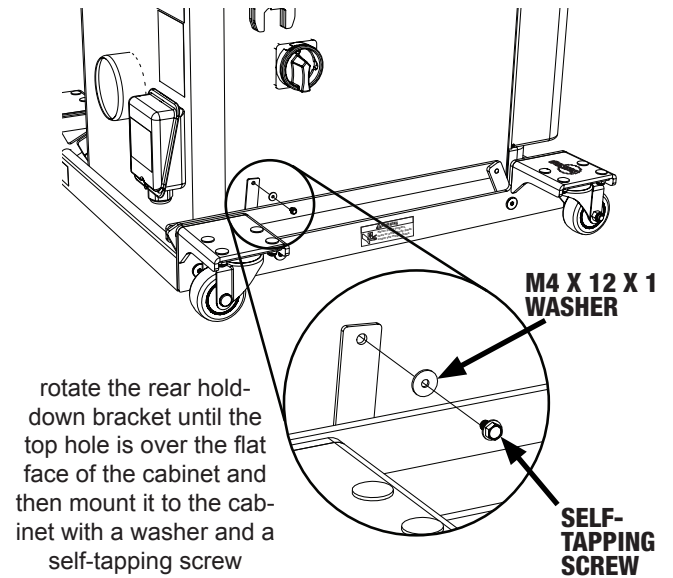

8 Rotate the front hold-down bracket until it is vertical and repeat the same procedure in step 7 to mount it to the cabinet.

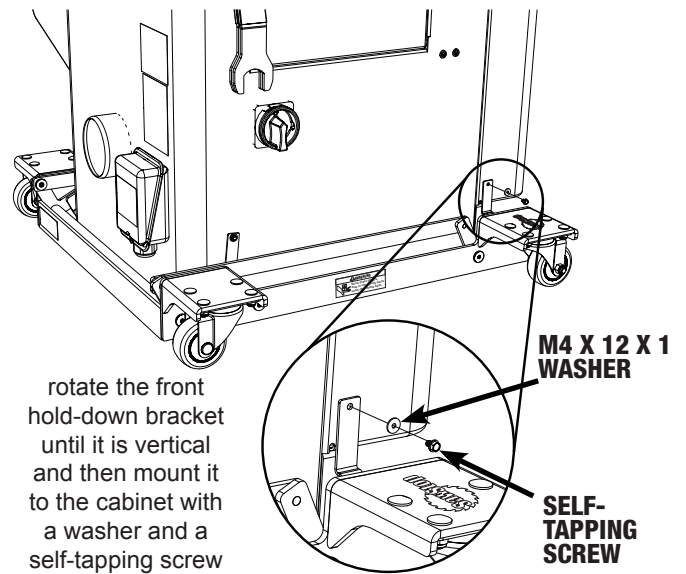

Congratulations! You have completed the Hold-Down Strap Installation. Continue to the following page for next steps.

Assembling and Installing the Support Legs and Power Switch

Requires: Assembled 30" x 16" Cast Iron Router Table
Power Switch (RT-PSW) Parts and Hardware Bags
Support Legs (RT-ST2) Parts and Hardware Bag
Phillips Head Screwdriver
16mm Wrench (x2)

Your existing extension table support legs are the exact same as the In-Line Router Table Support Legs (RT-ST2). If you are planning on re-using the support legs from your extension table, refer to your table saw fence manual for instructions on how to remove the extension table and support legs, and remove the brackets from the top of the support legs. You will then skip step 1 below, since you already have two assembled support legs with feet. Use the Leg Mounting Hardware bag from the Power Switch for In-Line Router Tables box to start at step 3.



The hardware for the next two steps can be found in the Support Legs for In-Line Router Tables box.

- 1 Thread an M8 x 1.25 hex nut (2.2) all the way onto a foot (2.3), then thread the foot all the way into the base of a support leg (2.1). Repeat this process with another hex nut, foot, and support leg.

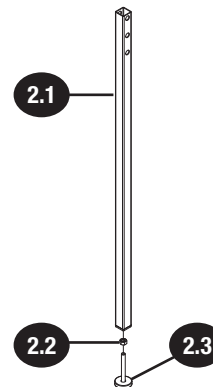

The hardware for the following steps can be found in the Leg Mounting Hardware bag (3.23) from the Power Switch for In-Line Router Tables box.

- 2 Align the top and third-down holes in one of the support legs (2.1) with the two holes on the inside of the right edge of the leg mounting bracket with the power switch (3.1) (from the perspective of the front of the power switch).

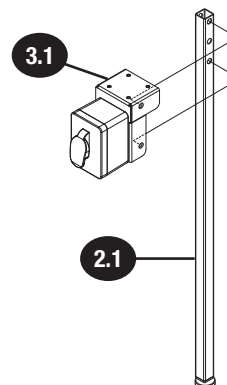

- 3** Insert an M10 hex head bolt (3.2) through an M10 washer (3.3), then through one of the exposed mounting holes in the leg mounting bracket and support leg, through another washer (3.3), and then through an M10 lock nut (3.4). Repeat this process for the other set of exposed mounting holes in the leg mounting bracket and support leg. Use two 16mm wrenches to tighten the lock nuts (3.4) on the bolts (3.2).

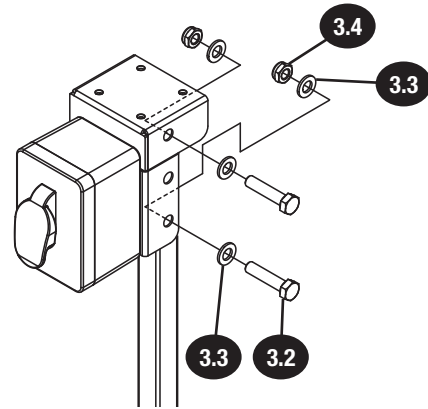

- 4** Align the top and third-down holes in the other support leg (2.1) with the two holes on the left side of the other leg mounting bracket (3.7) (from the perspective of the flat edge of the bracket).

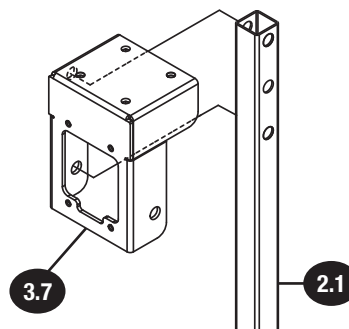

- 5** Insert an M10 hex head bolt (3.2) through an M10 washer (3.3), then through one of the exposed mounting holes in the leg mounting bracket (3.7) and support leg, through another washer (3.3), and then through an M10 lock nut (3.4). Repeat this process for the other set of exposed mounting holes in the bracket and support leg. Use two 16mm wrenches to tighten the lock nuts (3.4) on the bolts (3.2).

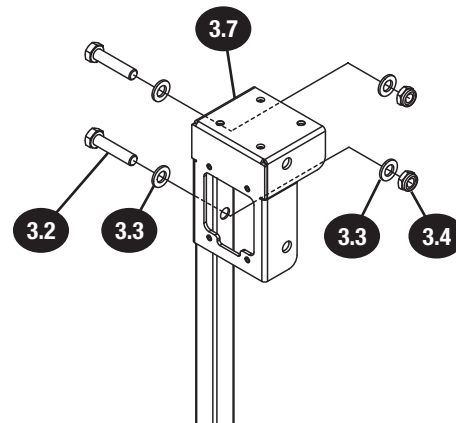

- 6** Next, mount the handle mounting bracket (3.11) to the front of the leg mounting bracket without the power switch (3.7). Align the square hole in the handle mounting bracket with the left of the two holes in the front of the bracket. (The handle mounting bracket is adjustable and can be aligned any way the user desires to hold the router lift elevation handle.)

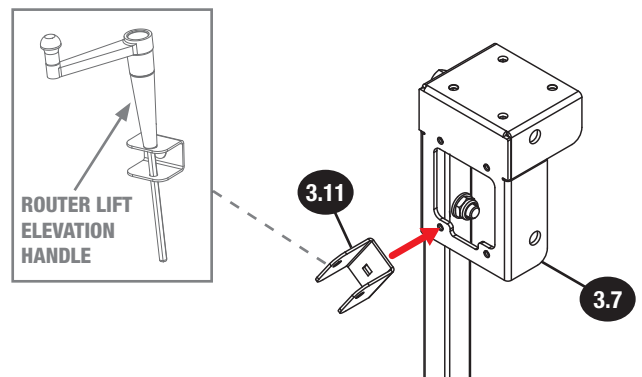

- 7** Insert an M5 x 30 pan head Phillips screw (3.12) through an M5 lock washer (3.9) and an M5 washer (3.10), then through the exposed mounting holes in the handle mounting bracket (3.11) and leg mounting bracket. Use a Phillips head screwdriver to secure the screw.

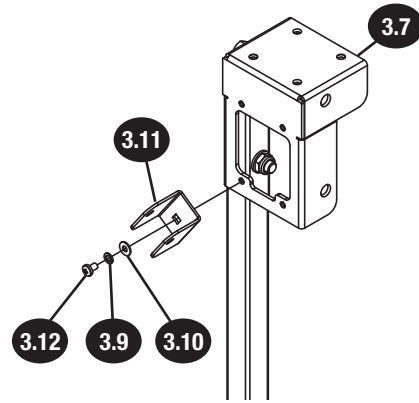

- 8** Next, install the screw that is used to store the insert wrench that comes with your router lift. Insert an M5 x 30 pan head Phillips screw (3.8) through an M5 lock washer (3.9) and an M5 washer (3.10), then all the way through the back of the remaining small hole in the front of the leg mounting bracket (3.7). Use a Phillips head screwdriver to secure the screw.

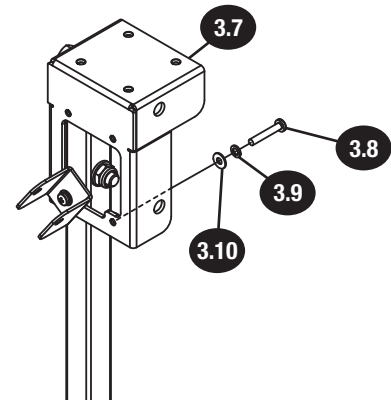

- 9** Attach the support legs to the underside of your router table. Place your router table upside-down on a flat surface, such as the floor. Find the two sets of threaded holes near the front of the table (indicated by the red arrows in Figure 12). The leg brackets with the power switch can each be installed on either the left or right side of your table, depending on the user's preference.

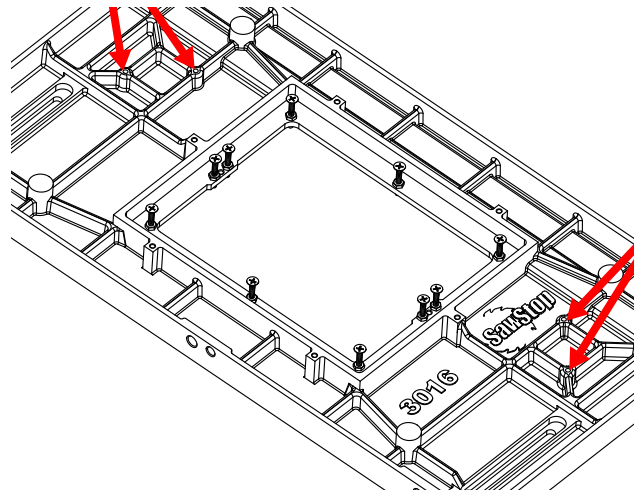

- 10** Position one of the leg mounting brackets (and attached support leg) upside-down above the router table, with the front of the leg mounting bracket (either the switchbox or the handle mounting bracket) facing towards the front of the table so it is accessible when the table is flipped back over and installed on your Industrial Cabinet Saw. Insert an M6 socket head cap screw (3.6) through an M6 lock washer (3.5) and then through one of the exposed holes in the leg mounting bracket and router table. Use a 5mm hex wrench to tighten the screw (3.6). Repeat this process for the other hole in the leg mounting bracket that lines up with a threaded hole in the table.

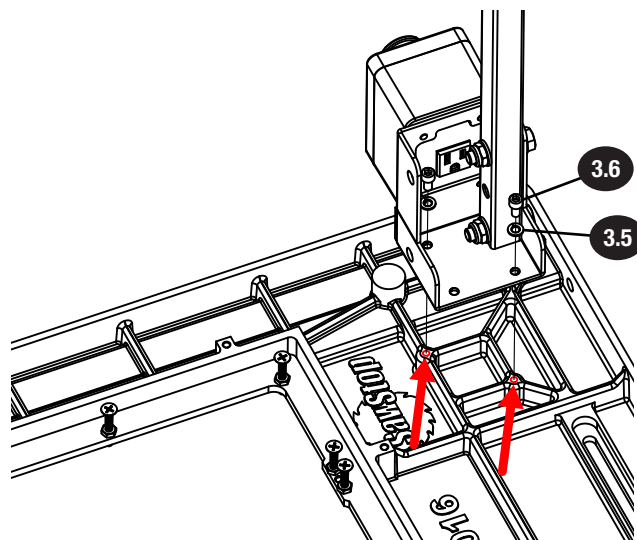

- 11** Repeat step 10 for the other hole in the leg mounting bracket that lines up with a threaded hole in the table.

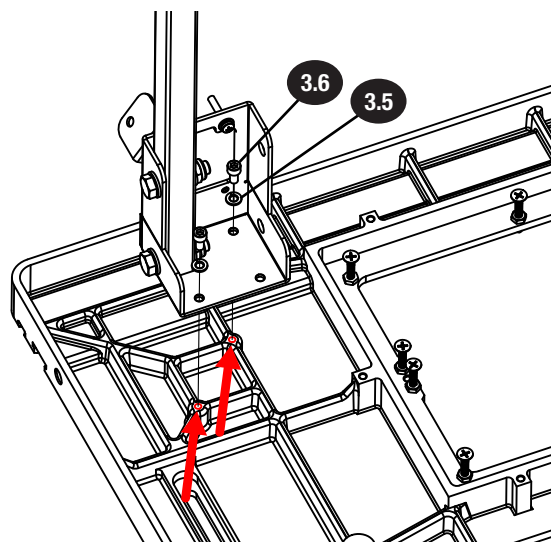

Next, install the router table in one of the three in-line configurations for your Industrial Cabinet Saw. See pages 1-3 for details regarding the three in-line mounting configurations.

- For mounting to the left extension wing, proceed to the next page.
- For mounting near the right extension wing with 36" rails, proceed to page 23.
- For mounting to the right extension wing with 52" rails and a 36" extension table, proceed to page 25.

In-Line Installation Left of Left Wing

Requires: “Wing Mounting Hardware” Bag from Power Switch (RT-PSW) Box
“Rail Mounting Hardware” Bag from Power Switch (RT-PSW) Box
30” x 16” Cast Iron Router Table with Support Legs Attached
Straight Edge
13mm Wrench (x2)



THIS PROCEDURE REQUIRES TWO PEOPLE. THE CAST IRON TABLE IS HEAVY AND CAN CAUSE SERIOUS PERSONAL INJURY OR DAMAGE IF DROPPED.



The hardware for this procedure can be found in the “Wing Mounting Hardware” bag included in your Power Switch box. You will not use all the hardware from the bag.

- 1 Align the upper three mounting holes in the router table with the three holes in the left extension wing of your Industrial Cabinet Saw.

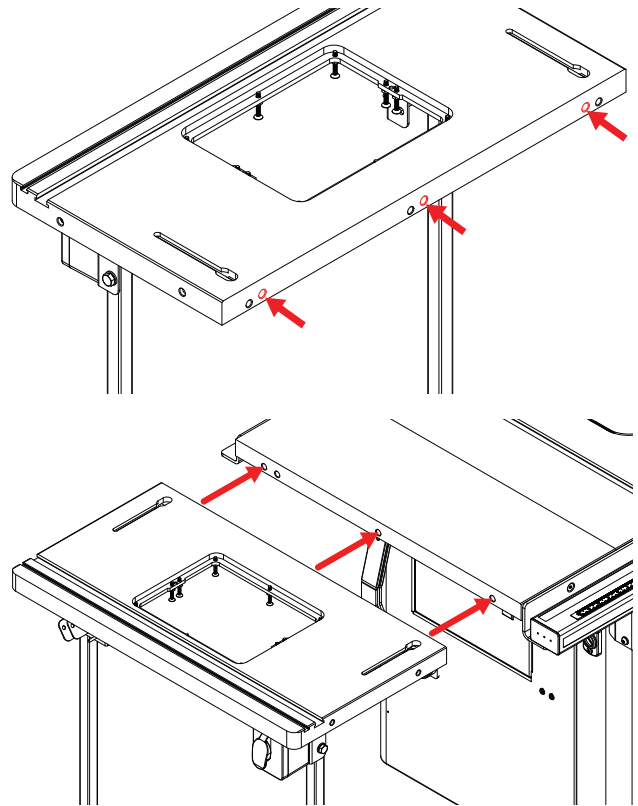

- 2** Insert an M8 head bolt (3.13) through an M8 washer (3.14), through one of the holes in the left extension wing, then through one of the holes in the router table. Secure the bolt with another washer (3.14), an M8 lock washer (3.15), and an M8 hex nut (3.16). Only finger tighten the hex nut at this time. Repeat this process for the remaining two holes in the extension wing and router table.

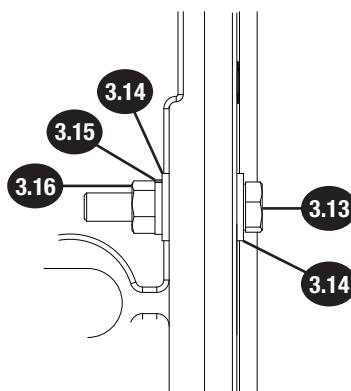
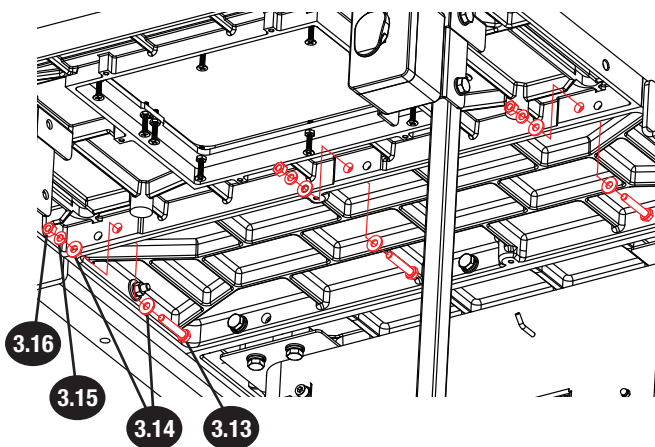

- 3** Lay a straight edge across the front of the extension wing so that it extends over the top of the router table as well. Make sure the router table is flush with the top of the extension wing and then use two 13mm wrenches to tighten the bolt and hex nut closest to the front of the extension wing. Repeat the process at the rear of the extension wing, then recheck both ends and tighten the center bolt and hex nuts.

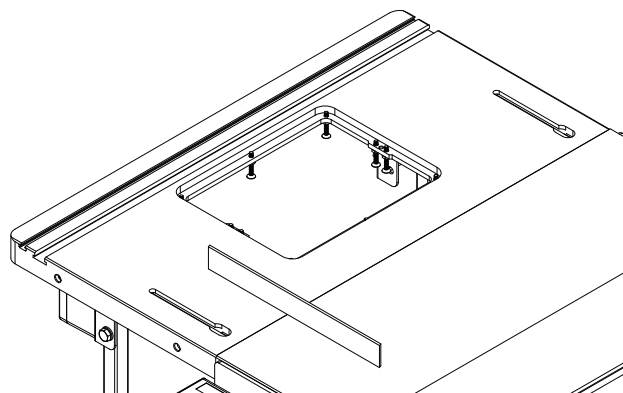

- 4** Adjust the feet in the support legs until they contact the ground and keep the router table level. Then use a 13mm wrench to tighten the M8 x 1.25 hex nuts (2.2) up against the bottoms of the support legs.

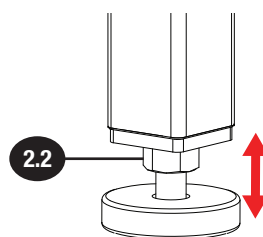

Congratulations! You have completed the In-Line Installation Left of Left Wing section. Continue to page 31 for next steps.

Rail Requirements: In-Line Right of ICS Right Wing

Use the figures below to verify your rails are compatible with the In-Line configuration on the right wing of your Industrial Cabinet Saw. **If your rails are not already compatible**, you may choose to:

- Install your In-Line Router Table left of the left wing
- Purchase RT-Ready Replacement Rails (in green below)
- Modify your existing rails. NOTE: SawStop-approved installation requires using SawStop-manufactured RT rails. No cut templates for rail modification are available from SawStop.

36" Rails

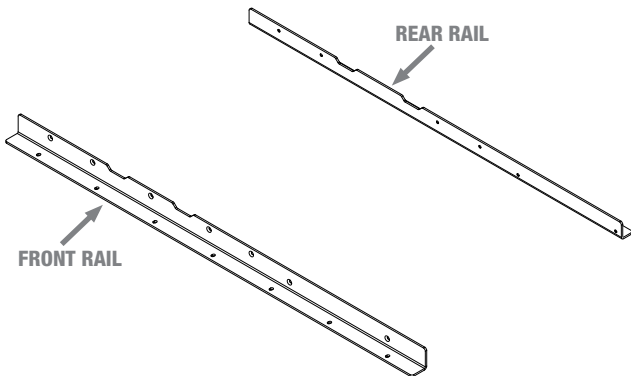

36" Industrial Rails
Part Number: CBFR105 3600 Rails
NOT COMPATIBLE

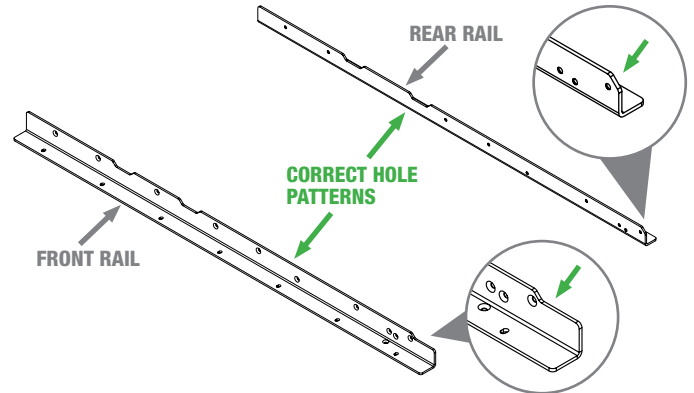

36" Industrial Series II Rails
Part Numbers: RT-TGI2-R36A
and TGI2-R36A
COMPATIBLE

(Notice notched ends and additional mounting holes in front and rear rails)

52" Rails

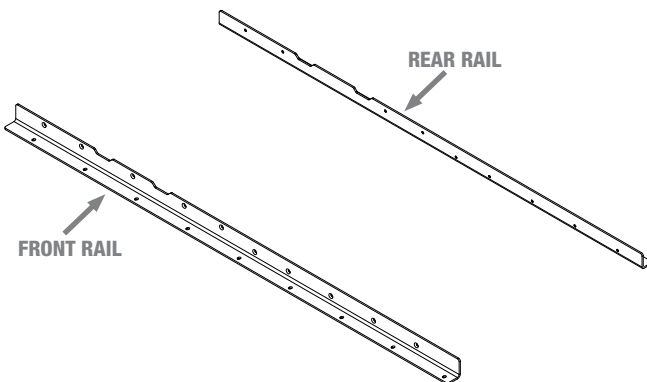

52" Industrial Rails
Part Number: CBFR104 5200 Rails
NOT COMPATIBLE

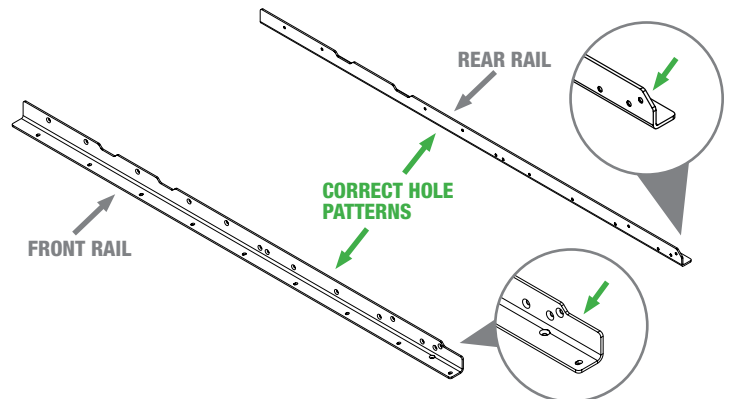

52" Industrial Series II Rails
Part Numbers: RT-TGI2-R52A
and TGI2-R52A
COMPATIBLE

(Notice notched ends and additional mounting holes in front and rear rails)

In-Line Installation Right: Between 36" Rails

- Requires:** “Rail Mounting Hardware” Bag from Power Switch (RT-PSW) Box
30" x 16" Cast Iron Router Table with Support Legs Attached
Straight Edge
13mm Wrench
5mm Hex Wrench
TGI2 Rails (**CBFR Rails are NOT Compatible**)



THIS PROCEDURE REQUIRES TWO PEOPLE. THE CAST IRON TABLE IS HEAVY AND CAN CAUSE SERIOUS PERSONAL INJURY OR DAMAGE IF DROPPED.

There will be a gap between the right edge of the right cast iron extension wing of your Industrial Cabinet Saw and the left edge of your router table. Users may choose to build an intermediate table to install between the cast iron extension wing and router table.

- 1 Use a 5mm hex wrench and a 13mm wrench to loosen the hardware securing your rear rail to your table saw. See your table saw fence manual for further information. (Copies of your manuals can be downloaded at www.sawstop.com.) SawStop recommends removing the main tube and loosening the hardware securing your front rail to your table saw.

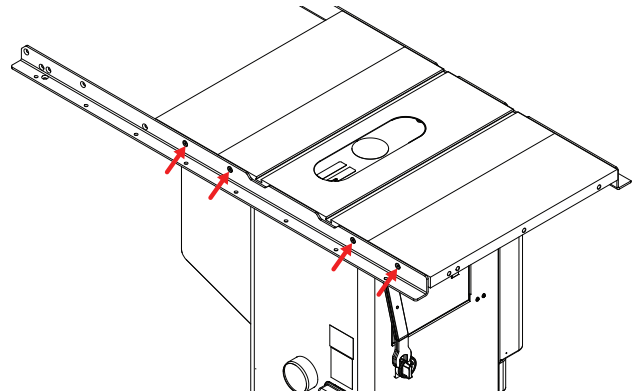

The hardware for the next steps can be found in the “Rail Mounting Hardware” bag included with the Power Switch (RT-PSW) box.

- 2 Place the router table between the front and rear 36" rails, at the far right end of the rails. Align the two mounting holes in each end of the cast iron table with the corresponding holes in the rails.

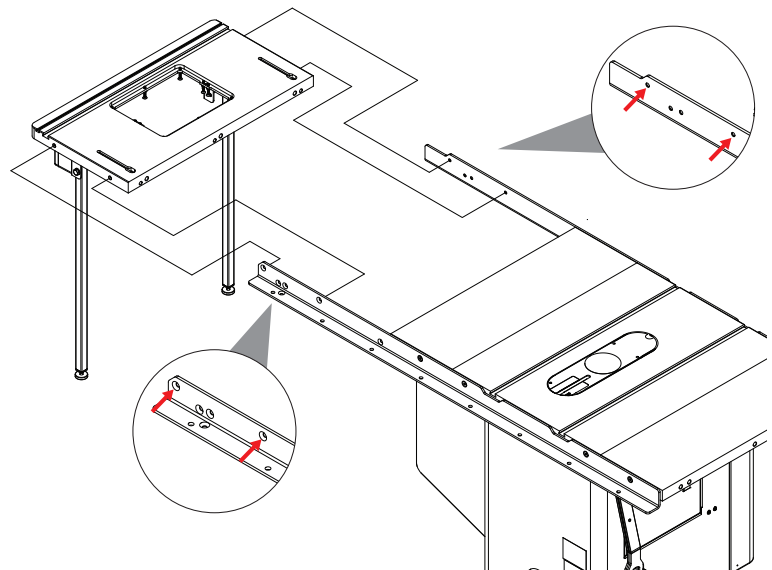

- 3** Next, mount the router table to the rails using the hardware from the “Rail Mounting Hardware” bag from your Power Switch (RT-PSW) box. Insert two M8 flat head socket screws (3.17) through the holes in the front rail and router table. Secure the screws with two M8 washers (3.18), two M8 lock washers (3.19), and two M8 hex nuts (3.20). Only finger tighten the nuts at this time. Repeat this process for the holes in the rear rail and rear edge of the router table.

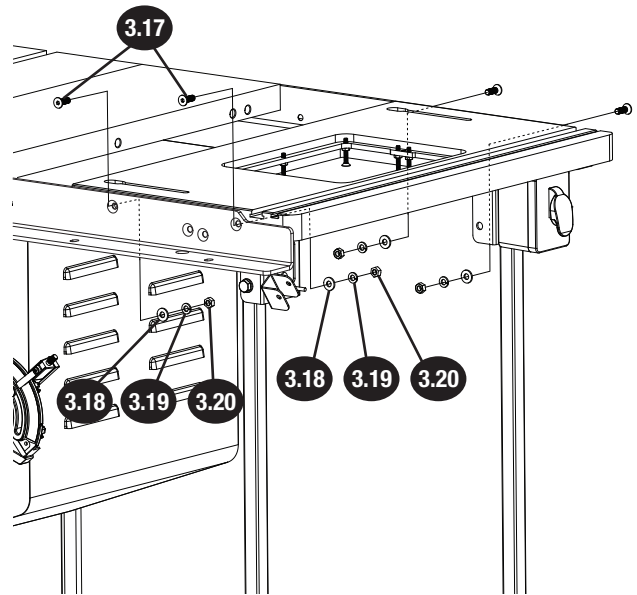

- 4** Lay a straight edge across the front of the right extension wing so that it extends over the top of the router table as well. Make sure the router table is flush with the top of the right extension wing and then use a 5mm hex wrench and a 13mm wrench to tighten the screws (3.17) and hex nuts (3.20) attaching the router table to the front rail. Repeat this process at the rear edge of the router table and right extension wing.

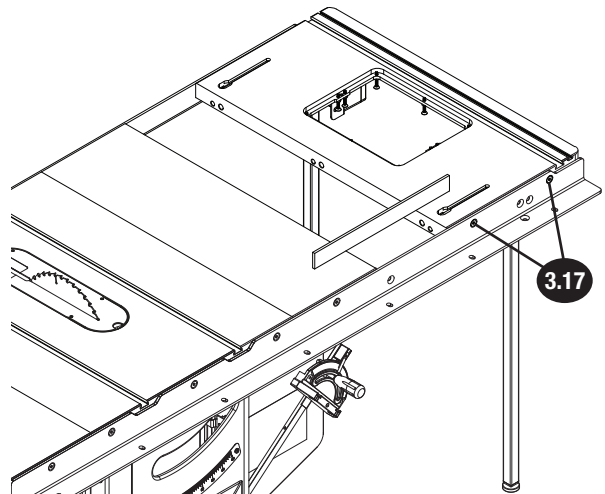

- 5** Adjust the feet in the support legs until they contact the ground and keep the cast iron table level. Then use a 13mm wrench to tighten the M8 hex nuts (2.2) up against the bottoms of the support legs.

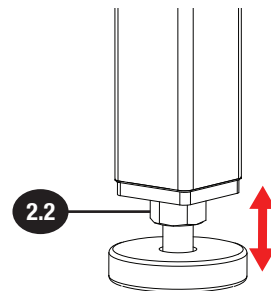

- 6** Follow the instructions in your table saw fence manual to reinstall the main tube and retighten the hardware securing your front and rear rail to your table saw. See your table saw fence manual for further information.

Congratulations! You have completed the In-Line Installation Right: Between 36" Rails section. Continue to page 31 for next steps.

In-Line Installation Right: Between 52" Rails

Requires: “Wing Mounting Hardware” Bag from Power Switch (RT-PSW) Box
“Rail Mounting Hardware” Bag from Power Switch (RT-PSW) Box
30” x 16” Cast Iron Router Table with Support Legs Attached
36” Extension Table
Straight Edge
13mm Wrench (x2)
3/8” Drill Bit
Drill
C-Clamp (x2)
TGI2 Rails (**CBFR Rails are NOT Compatible**)



THIS PROCEDURE REQUIRES TWO PEOPLE. THE CAST IRON TABLE IS HEAVY AND CAN CAUSE SERIOUS PERSONAL INJURY OR DAMAGE IF DROPPED.



The hardware for the following steps can be found in the box for your 36” extension table.

- 1 If your rails are not installed on your saw, install them now according to the instructions in your table saw fence manual. **Do not fully tighten the hardware.** If your rails are already installed on your saw, use a 13mm wrench to remove the main tube (set it aside) and use a 13mm wrench and a 5mm hex wrench to loosen the hardware securing the rear rail to the saw. See your table saw fence manual for further information. (Copies of your manuals can be downloaded at www.sawstop.com.)

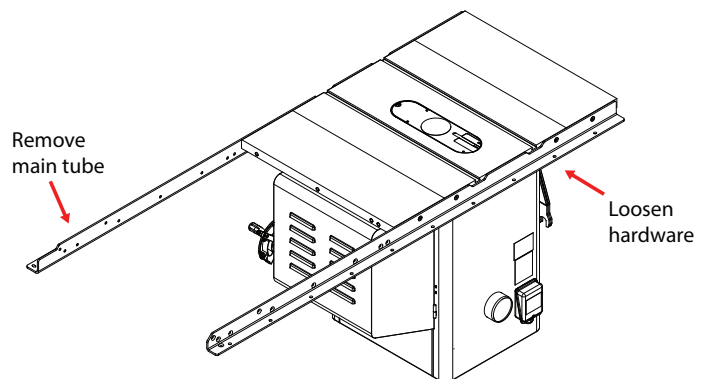

YOU WILL NOT USE ALL THE HARDWARE OR BRACKETS THAT ARE INCLUDED WITH YOUR 36" EXTENSION TABLE.



Once the rails are in place, you can mount the extension table to the rails. You will not use all the hardware or brackets that are included with your 36" extension table. Follow the instructions in your table saw fence manual to install the table. First, drill holes in the sides of the table to mount it to the rails. Note that the holes that are closest to the wing are already drilled.

2

Place the extension table between the rails and slide it towards the extension wing. Be careful when positioning the extension table because it is not yet secured to the rails and could fall.

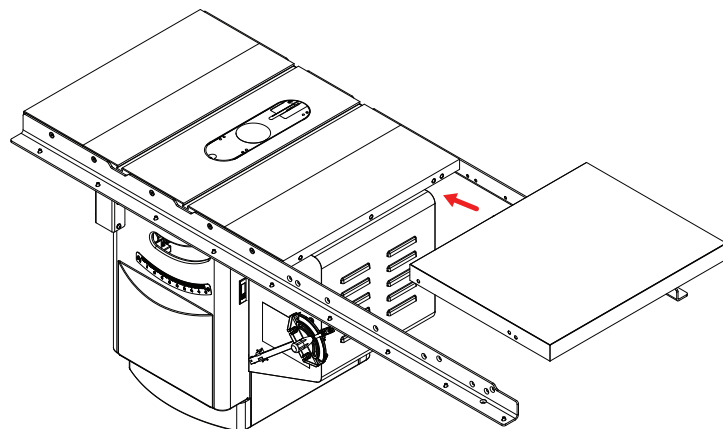

3

The extension table mounts to the rails with bolts that pass through holes in the rails and extension table. Take two M8 flat head socket screws from your extension table hardware, and insert one through the hole in the front rail closest to the saw and the other through the hole in the rear rail closest to the saw. Place an M8 washer, an M8 lock washer, and an M8 hex nut on the threaded end of each bolt, keeping them loose.

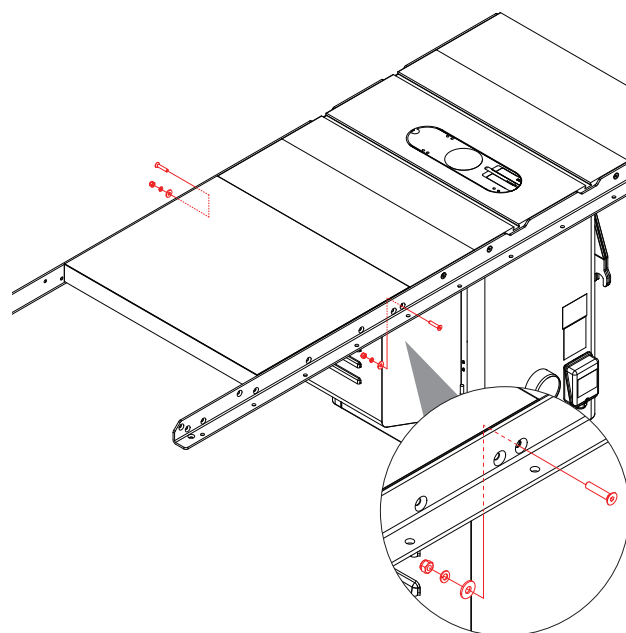

4

Use a level or straightedge to make sure the extension table is flush with the right wing of your saw. Then use two C-clamps to secure the right end of the extension table to the rails. Mark the extension table in the center of the three holes in the front rail and three in the rear rail.

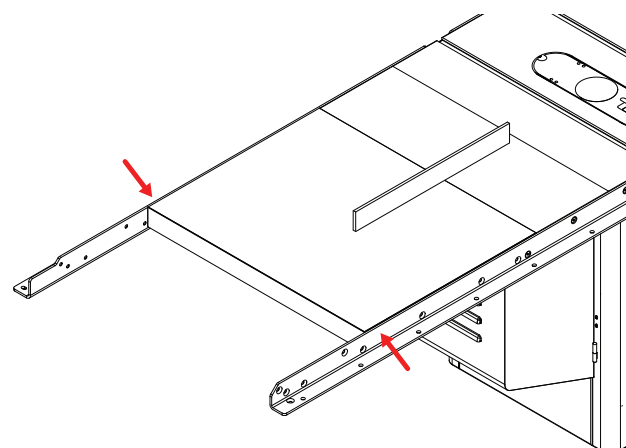

- 5** Remove the C-clamps and the extension table. Use a $\frac{3}{8}$ " drill bit to drill holes in the extension table in the locations you marked in the previous step.

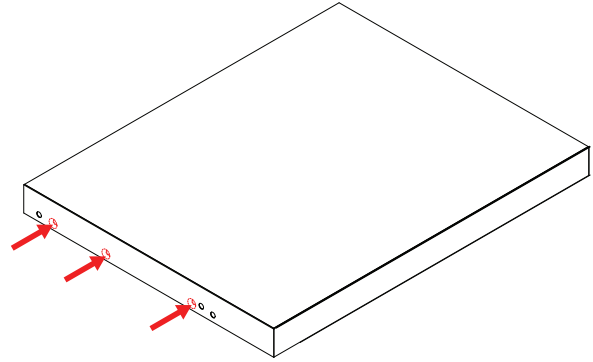

- 6** Follow the instructions in your table saw fence manual to install the 36" extension table in your 52" rails, and secure it with at least four M8 flat head socket screws, washers, lock washers, and hex nuts from your extension table hardware.

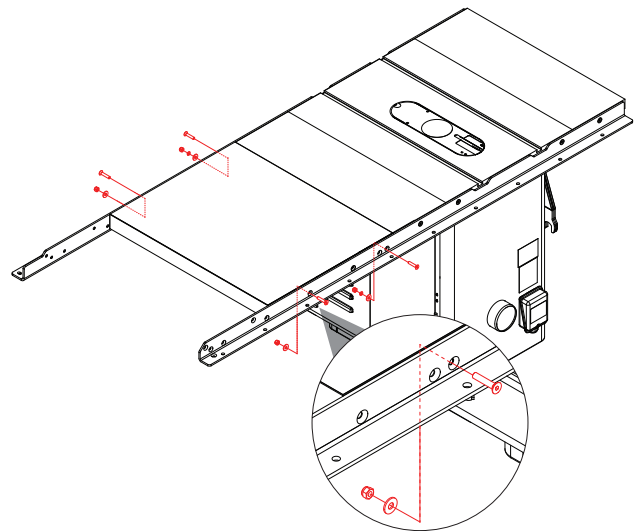

- 7** Align the router table (with attached support legs) with the right edge of the extension table, making sure that the tops of the saw table and extension table are level.

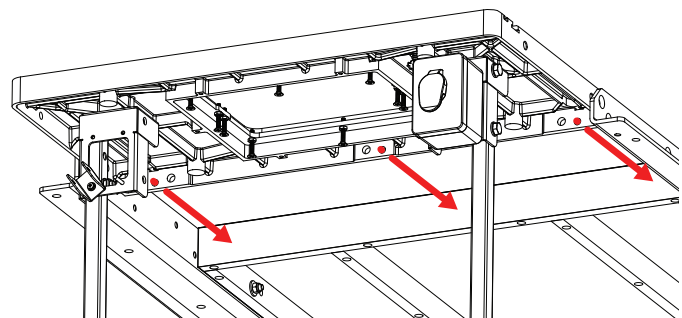

- 8 There are two sets of three holes in the edge of your router table. Mark the extension table in the center of each of the three **lower** holes in the router table. Then set the router table (and attached support legs) aside.

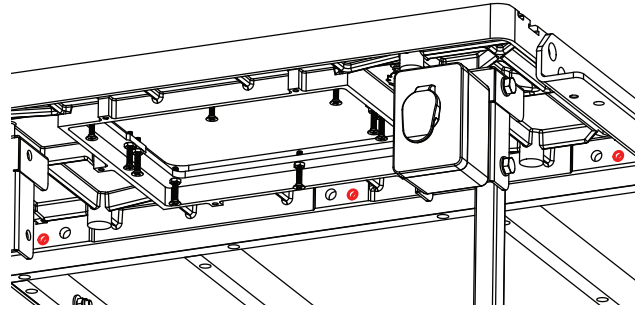

- 9 Use a $\frac{3}{8}$ " drill bit to drill holes in the edge of the 36" extension table at the three spots you marked in the previous step, shown by the red arrows.

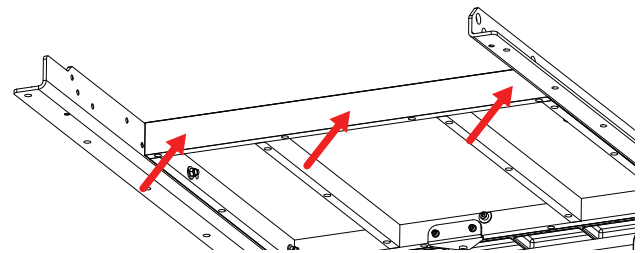

- 10 Align the three lower holes in the router table with the holes you just drilled in the 36" extension table.

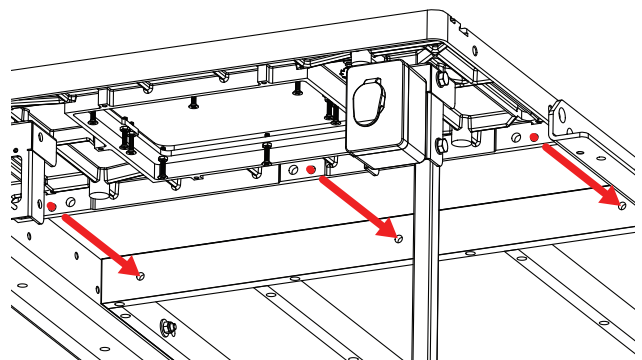



The hardware for the next steps can be found in the “Wing Mounting Hardware” bag from your Power Switch (RT-PSW) box. You will not use all the hardware from the bag.

- 11** Next, mount the router table to the 36” extension table using some of the hardware from the “Wing Mounting Hardware” bag from your Power Switch (RT-PSW) box. Insert three M8 hex head bolts (3.13) through three M8 washers (3.14), then through the router table and extension table. Secure the bolts with three more washers (3.14), three M8 lock washers (3.15), and three M8 hex nuts (3.16). Only finger tighten the hex nuts at this time.

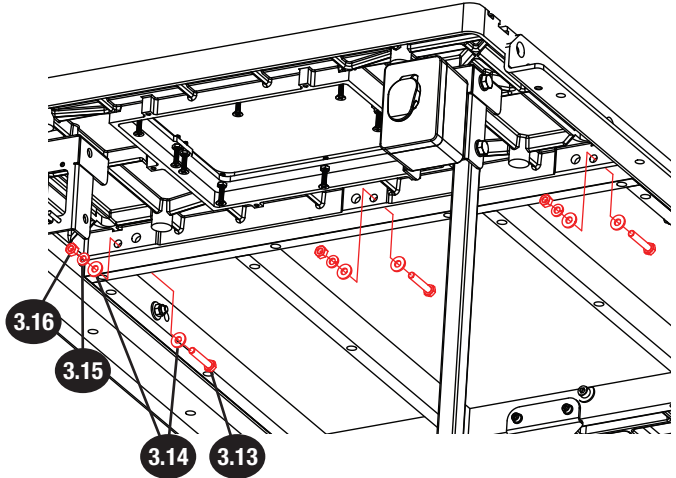

- 12** Lay a straight edge across the front of the extension table so that it extends over the top of the router table as well. Make sure extension table is flush with the top of the router table, and then use two 13mm wrenches to tighten the bolt and hex nut closest to the front of the router table. Repeat the process at the rear of the cast iron table, then recheck both ends and tighten the center bolt and hex nut. The holes in the extension table and cast iron table are slightly larger than the bolts they receive. This allows some adjustment for the height of the cast iron table relative to the 36” extension table. To adjust the height, push down or pull up on the router table and then tighten the nuts.

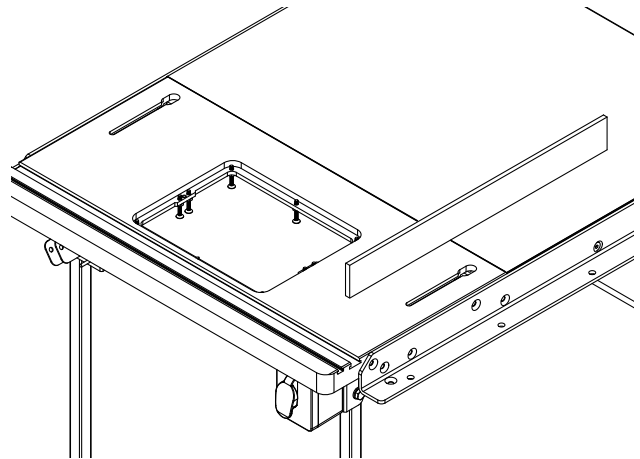

- 13** Adjust the feet in the support legs until they contact the ground and keep the cast iron table level. Then use a 13mm wrench to tighten the M8 hex nuts (2.2) up against the bottoms of the support legs.

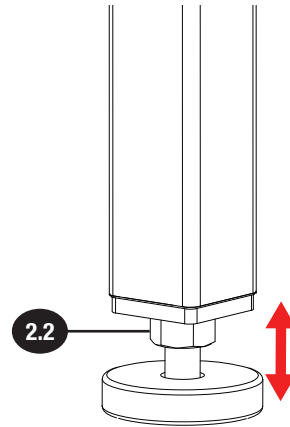

The hardware for the next steps can be found in the “Rail Mounting Hardware” bag from your Power Switch (RT-PSW) box.

- 14** Next, mount the router table to the front and rear rails using the hardware from the “Rail Mounting Hardware” bag from your Power Switch (RT-PSW) box. Insert four M8 flat head socket screws (3.17) through the holes in the front and rear rails and router table. Secure the screws with four M8 washers (3.18), four M8 lock washers (3.19), and four M8 hex nuts (3.20). Use a 5mm hex wrench and a 13mm wrench to tighten the hex nuts.

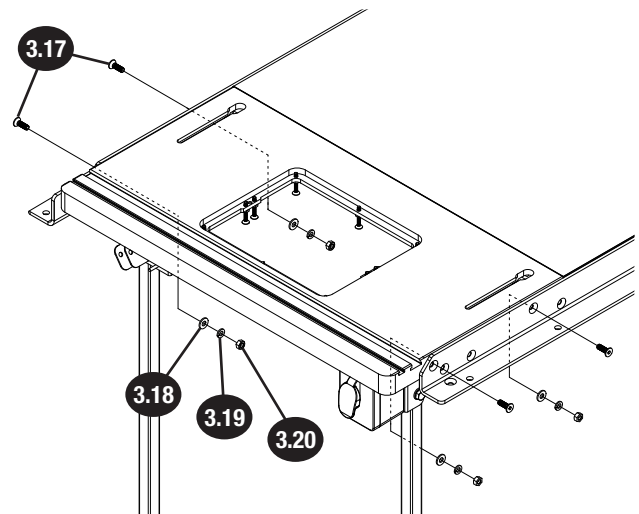

- 15** Follow the instructions in your table saw fence manual to reinstall the main tube and retighten the hardware securing your front and rear rail to your table saw. See your table saw fence manual for further information.

Congratulations! You have completed the In-Line Installation Right: Between 52" Rails section. Continue to the following page for next steps.

Assembling the 32" Fence Assembly

Requires: Hardware bag for 32" Fence Assembly for Router Tables (RT-F32)
Parts for 32" Fence Assembly for Router Tables (RT-F32)
Phillips Head Screwdriver



You will not use all of the components or hardware that come with your 32" fence. The two 32" table rails, rail rulers, rail mounting brackets, and other hardware are not used in this configuration of the 32" Fence Assembly.

- 1 Thread a 1/4" pan head Phillips screw (4.11) into one of the two holes on the side of the 2 1/2" dust port (4.10), then thread a 1/4" square nut (4.12) partway onto the end of the screw. Repeat this process with another 1/4" pan head Phillips screw and 1/4" square nut, but thread the screw in the hole on the other side of the dust port.

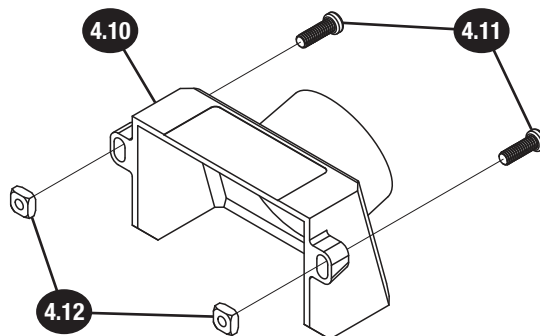

- 2 Slide the two 1/4" - 20 square nuts (4.12) into the lower T-slot on the back of the router table fence (4.1) until the dust port is aligned with the large opening in the back of the fence. Use a Phillips screwdriver to tighten the screws to secure the dust port to the router table fence.

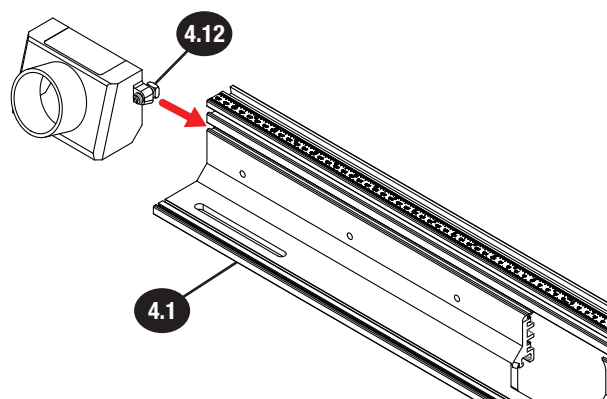

3 Insert a T-bolt (4.8) through one of the six holes in the vertical portion of the router table fence (4.1), so the head of the T-bolt is on the front of the fence (the side with three T-slots) and the threaded portion of the T-bolt is on the rear of the fence (the side with two T-slots and the bent edge). Slide an M6 washer (4.7) onto the end of the T-bolt and then thread a fence face plate lock knob (4.6) onto the T-bolt, until the end of the T-bolt is flush with the outer edge of the lock knob. Repeat this process for the remaining five holes in the vertical portion of the router table fence.

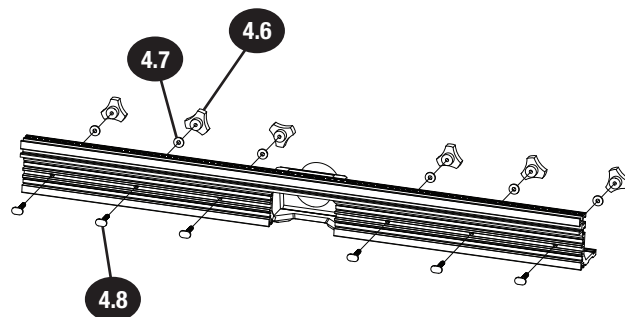

4 Slide the T-slot in the back of a router fence face plate (4.14) onto three of the T-bolts (4.8) you just installed.

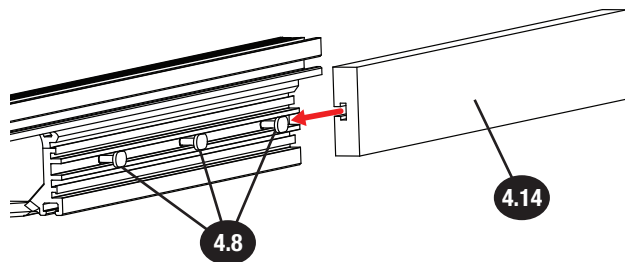

5 Slide the other router fence face plate (4.14) onto the other three T-bolts (4.8) you just installed. The router fence face plates should cover the entire front of the router fence at this time.

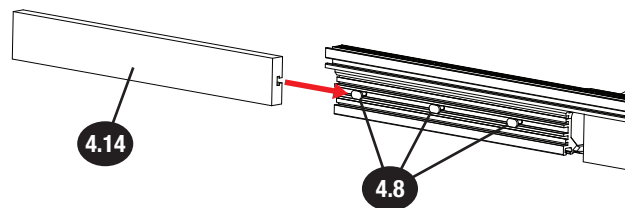

- 6** Tighten the six lock knobs (4.6) to secure the router fence face plates (4.14). To adjust the router fence face plates, loosen the lock knobs on the back of the fence and slide the router fence face plates away from each other until they do not interfere with the router bit, then retighten the lock knobs.

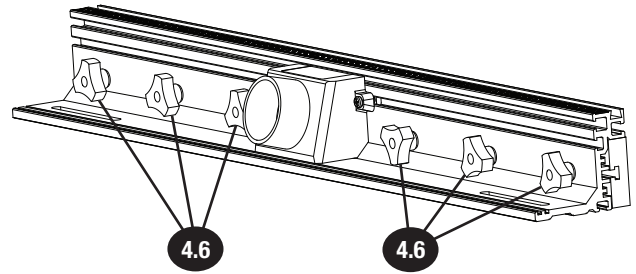

ALWAYS MAKE SURE THE LOCK KNOBS ARE FULLY TIGHTENED BEFORE USING THE FENCE!

- 7** Insert a T-bolt (4.8) through a router fence guard spacer (4.16), with the square part of the spacer adjacent the head of the T-bolt and the rounded part of the spacer facing away from the head of the T-bolt. Repeat this process with another T-bolt (4.8) and another router fence guard spacer (4.16). Slide the router fence guard (4.15) onto the two T-bolts, so the rounded parts of the spacers extend into the elongated vertical holes in the router fence guard. Secure each T-bolt (4.8) with an M6 washer (4.7) and a fence face plate lock knob (4.6). Do not tighten the lock knobs.

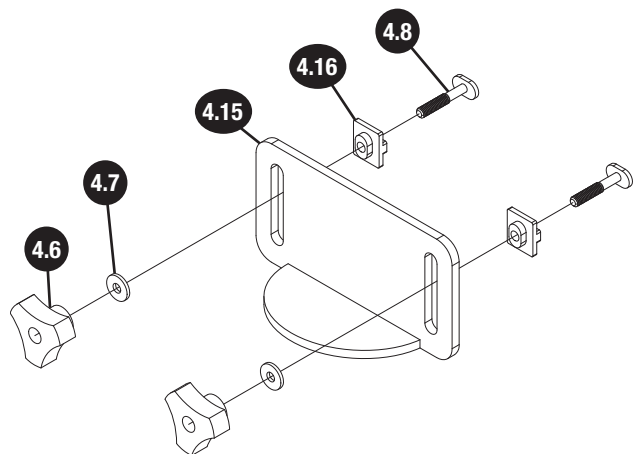

8 Slide the heads of the T-bolts into the top T-slot in the front of the vertical section of the router fence (4.1). The semicircular, bent portion of the router fence guard (4.15) should face away from the router table fence. The height of the router fence guard relative to the router table can be adjusted by loosening the lock knobs, moving the router fence guard up or down, and retightening the lock knobs.

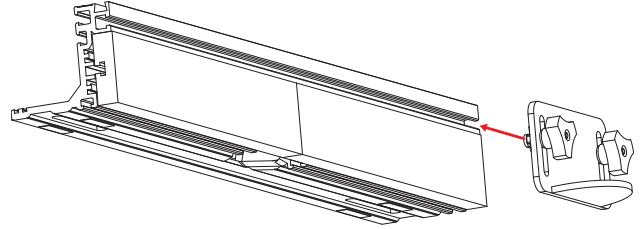

9 The next step is to attach the router table fence to the router table. Insert a fence lock knob (4.2) through an M8 washer (4.3), then through one of the two elongated holes in the rear of the router table fence (4.1), and then thread a 23mm wide lock knob nut (4.4) partway onto the end of the fence lock knob. Repeat this process with another fence lock knob, M8 washer, and 23mm wide lock knob nut.

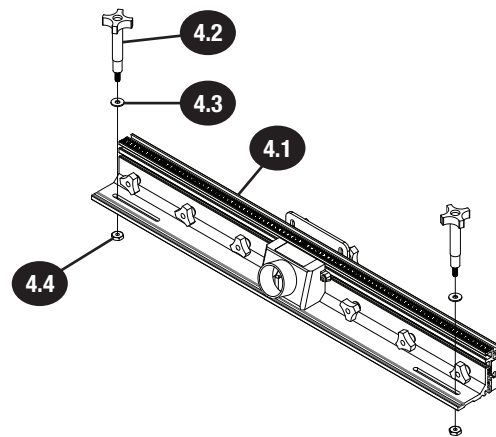

10 Slide the 23mm wide lock knob nuts (4.4) into the round ends of the elongated holes in your router table, then slide the fence forward. Use the fence lock knobs (4.2) to secure the router fence in place.

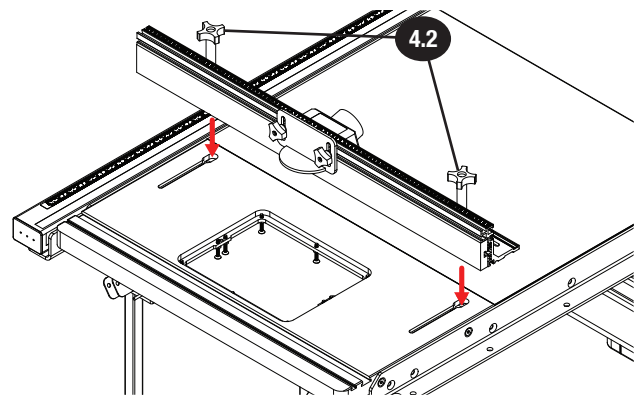

11 If you have a Downdraft Dust Collection Box for Router Lift (RT-DCB) installed, use the provided dust hose and hose clamps to secure the 2 ½” dust hose to the router table fence to the dust port splitter on the dust box. Further information can be found in your Four Post Router Lift manual, which includes information about the dust box as well. Copies of your manuals can be downloaded at **www.sawstop.com**. Otherwise, use a 2 ½” dust hose (not provided) and two dust hose clamps (not provided) to attach the 2 ½” dust port on the router table fence directly to a dust collection system.

i If there is excess dust hose length between the 32” fence and the dust box, you can shorten the dust hose.

i When making jointer cuts, it can be useful to offset one router fence face plate (4.14) relative to the other router fence face plate. Two fence face plate space bars (4.13) are used to do this, and they can be installed to offset the router fence face plates by either 0.7mm or 1.5mm. It is important to install both fence face plate space bars facing the same direction, so they both extend either 0.7mm or 1.5mm beyond the edge of the fence. To install the fence face plate space bars (4.13), loosen the three lock knobs (4.6) on one side of the back of the router table fence (4.1), and slide the two fence face plate space bars onto the two T-shaped extensions behind the fence face plate. Then retighten the three lock knobs to secure the fence face plate in place.

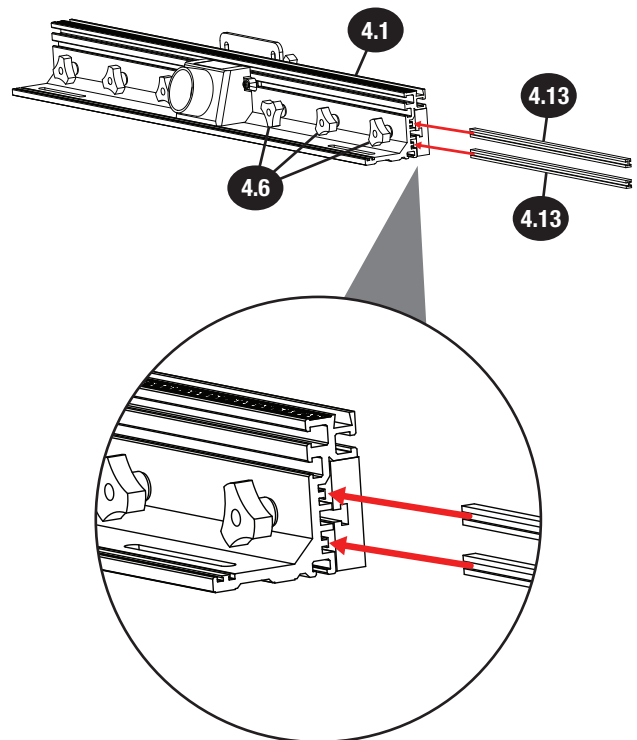

Warranty

SawStop warrants to the original retail purchaser of a new ICS In-Line Router Table Assembly from an authorized SawStop distributor that the ICS In-Line Router Table Assembly system will be free from defects in material and workmanship for ONE YEAR from the date of purchase. SawStop warrants to the original retail purchaser of a refurbished, demonstration or floor model ICS In-Line Router Table Assembly from an authorized SawStop distributor that the ICS In-Line Router Table Assembly system will be free from defects in material and workmanship for SIX MONTHS from the date of purchase.

This warranty does not apply to defects arising from misuse, abuse, negligence, accidents, normal wear-and-tear, unauthorized repair or alteration, or lack of maintenance. This warranty is void if the ICS In-Line Router Table Assembly system or any portion of the ICS In-Line Router Table Assembly system are modified without the prior written permission of SawStop, LLC, or if the ICS In-Line Router Table Assembly system are located or have been used outside of the country where the authorized SawStop distributor from whom the ICS In-Line Router Table Assembly system were purchased resides.

Please contact SawStop to take advantage of this warranty. If SawStop determines the ICS In-Line Router Table Assembly system is defective in material or workmanship, and not due to misuse, abuse, negligence, accidents, normal wear-and-tear, unauthorized repair or alteration, or lack of maintenance, then SawStop will, at its expense and upon proof of purchase, send replacement parts to the original retail purchaser necessary to cure the defect. Alternatively, SawStop will repair the ICS In-Line Router Table Assembly system provided they are returned to SawStop, shipping prepaid, with proof of purchase and within the warranty period.

SawStop disclaims any and all other express or implied warranties, including merchantability and fitness for a particular purpose. SawStop shall not be liable for death, injuries to persons or property, or incidental, consequential, contingent or special damages arising from the use of the ICS In-Line Router Table Assembly system.

This warranty gives you specific legal rights. You may have other rights which vary from state to state.

A router is a dangerous tool and there are hazards inherent with using your router. Some of these hazards are discussed below. Use common sense when operating your router and the SawStop ICS In-Line Router Table Assembly and use them only as instructed. Make sure to follow the safety rules and guidelines that are outlined in the manual of your specific router.

You are responsible for your own safety!

Warnings

1. Read and understand the instruction manual and all safety warnings before operating your router and SawStop ICS In-Line Router Table Assembly. Failure to comply with these warnings may result in serious personal injury. Save these instructions and refer to them whenever necessary.
2. Read and understand the instruction manual and all safety warnings of your router before using it with the SawStop ICS In-Line Router Table Assembly.
3. **WARNING:** This product contains one or more chemicals known to the State of California to cause cancer and birth defects or other reproductive harm. In addition, some types of dust created by sawing, power sanding, grinding, drilling, and other construction activities also contain chemicals known to cause cancer, birth defects or other reproductive harm. Some examples of these chemicals are lead from lead-based paints, crystalline silica from bricks, cement, and other masonry products, and arsenic and chromium from chemically treated lumber. In addition, wood dust has been listed as a known human carcinogen by the U.S. government. The risk from exposure to these chemicals and to dust varies depending on how often you do this type of work. To reduce your exposure, work in a well ventilated area and work with approved safety equipment including dust masks or respirators designed to filter out such dust and chemicals.
4. Keep guards in place and in working order.
5. For your own safety, read instruction manual before operating shaper.
6. Do not expose the ICS In-Line Router Table Assembly to rain or use in damp locations.
7. Do not operate your router without all guards and covers properly installed.
8. Do not use awkward hand positions when routing.

9. Do not operate your router, use the ICS In-Line Router Table Assembly, or any other tools under the influence of alcohol or drugs.
10. Wear proper apparel when using the ICS In-Line Router Table Assembly. Do not wear loose clothing, gloves, neckties, rings, bracelets, or other jewelry which may get caught in moving parts. Non-slip footwear is recommended. Wear a protective hair covering to contain long hair.
11. Always wear approved safety glasses and/or a face shield when using the ICS In-Line Router Table Assembly. Also use a face or dust mask if the cutting operation is dusty. Everyday eyeglasses are not safety glasses.
12. Keep hands away from router bits and use fixture when necessary. Never reach around or over the router. Use feather boards and/or push sticks to keep your hands away from the router bit. Keep proper footing and balance at all times.
13. Always run your workpiece against the rotation direction of the router bit. Never cut pieces between the fence and the router bit.
14. Always ensure the router bit is in good working condition before use. Examine the router bit prior to use and replace the bit if it is damaged.
15. Ensure the ICS In-Line Router Table Assembly, and your router are installed securely before use.
16. Maintain the ICS In-Line Router Table Assembly as specified in this manual. Use only identical replacement parts when servicing the In-Line Router Table.
17. Turn the power disconnect switch to OFF and unplug your router before servicing, making any adjustments, or cleaning the ICS In-Line Router Table Assembly. Always ensure the power is OFF before changing components or accessories such as router bits, guards, and the like.
18. Check to make sure the ICS In-Line Router Table Assembly is in working order before use. For example, check the alignment of moving parts, look to see whether moving parts are binding or rubbing, check to see whether parts are broken, make sure accessories are properly installed, and check any other conditions that may affect the operation of the ICS In-Line Router Table Assembly. Any parts that are damaged should be properly repaired or replaced.

Exploded View 1: 30" x 16" Cast Iron Router Table (RT-C30)

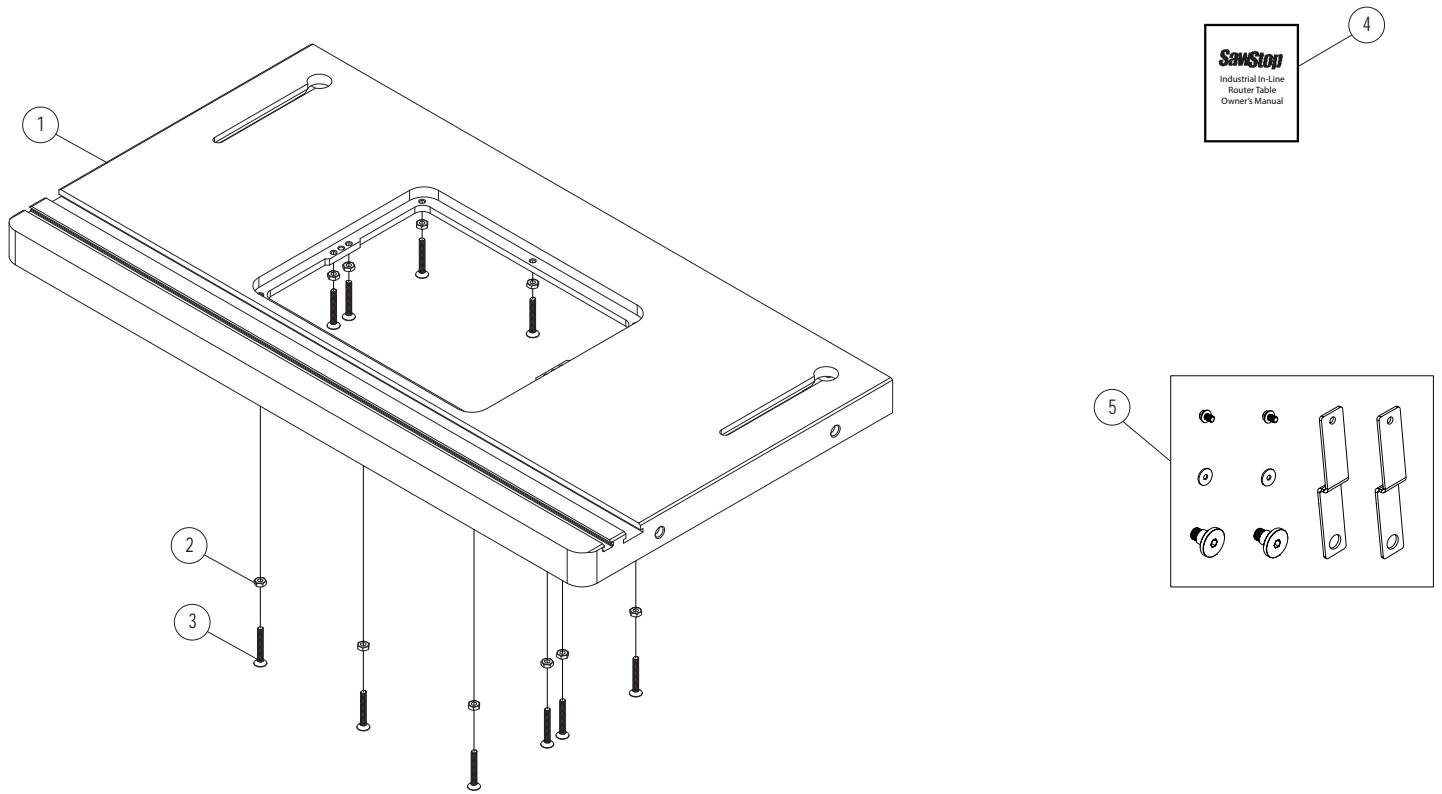

Parts List 1: 30" x 16" Cast Iron Router Table (RT-C30)

No.	Description	Part No.	Qty.
N/A	30" Router Table Assembly	RT-C30	1
1.1	30" Router Table	RT-C30-001	1
1.2	M6 x 1.0 Hex Nut	RT-C30-002	10
1.3	M6 x 1.0 x 40 Flat Head Phillips Screw	RT-C30-003	10
1.4	Industrial In-Line Router Table Owner's Manual	RT-C30-004	1
1.5	Mobile Base Cabinet Hold-Down Kit for Router Tables	RT-C30-005	1
	Includes:		
	Hold Down Bracket	MB-IND-502	2
	M8 x 18 Shoulder Socket Screw	MB-IND-504	2
	M4 x 12 x 1 Washer	MB-IND-505	2
	Thread Cutting Screw	MB-IND-506	2

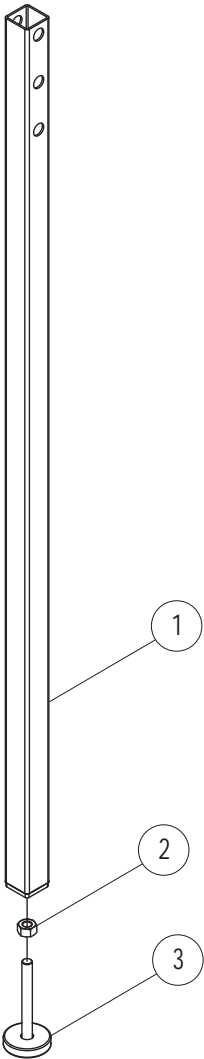
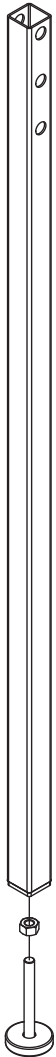

Parts List 2: Support Legs for In-Line Router Tables (RT-ST2)

No.	Description	Part No.	Qty.
N/A	Support Legs for In-Line Router Tables	RT-ST2	1
2.1	Support Leg	RT-ST2-001	2
2.2	M8 x 1.25 Hex Nut	RT-ST2-002	2
2.3	Foot	RT-ST2-003	2

Exploded View 3: Power Switch for In-Line Router Tables (RT-PSW)

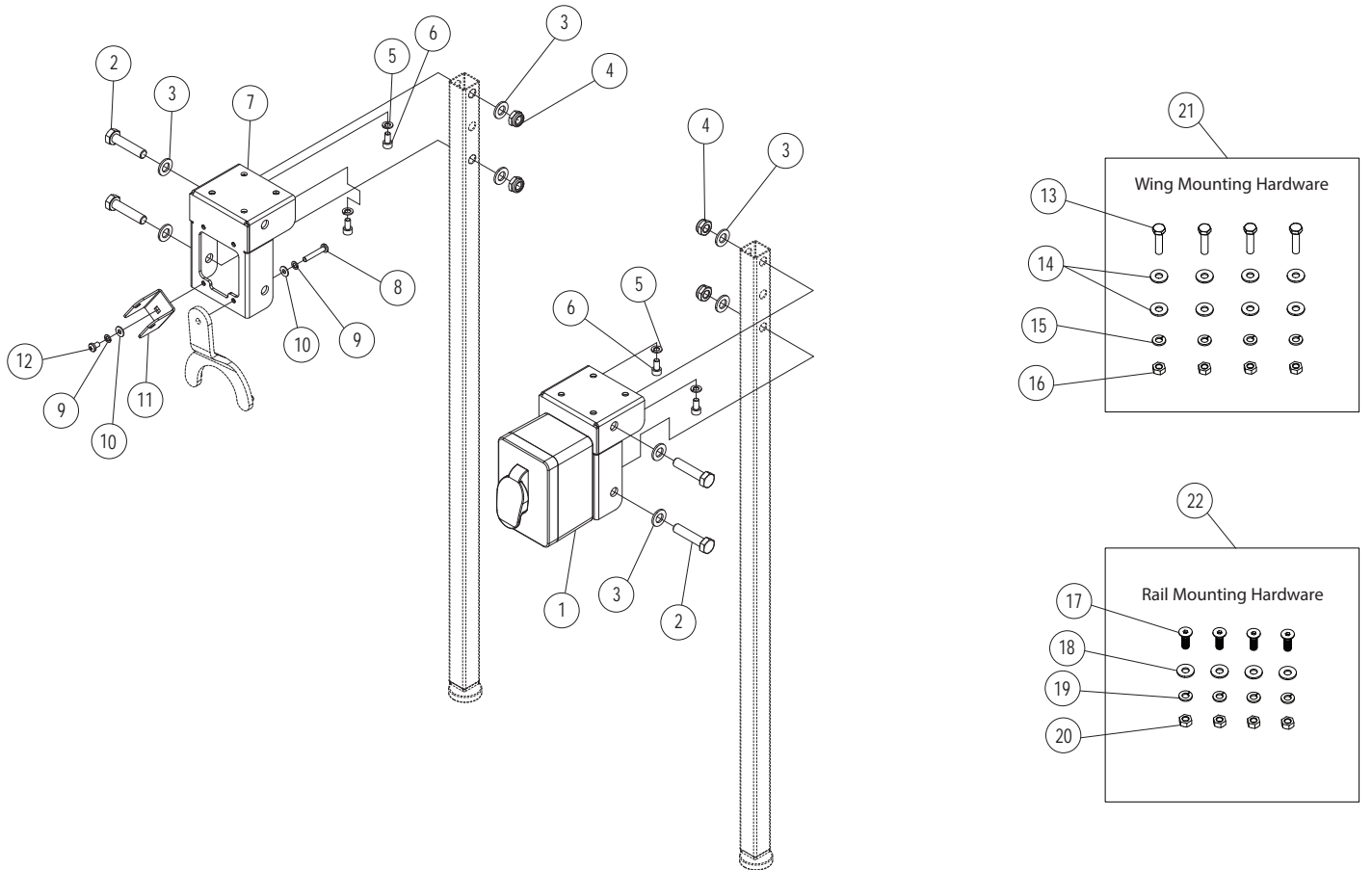

Parts List 3: Power Switch for In-Line Router Tables (RT-PSW)

No.	Description	Part No.	Qty.
N/A	In-Line Switch Box Mounting Kit	RT-PSW	1
3.1	In-Line Switch Box Mounting Bracket Assembly	RT-PSW-001	1
3.2	M10 x 1.5 x 45 Hex Head Bolt	RT-PSW-002	4
3.3	M10 x 19 x 2 Washer	RT-PSW-003	8
3.4	M10 x 1.5 Lock Nut	RT-PSW-004	4
3.5	M6 Lock Washer	RT-PSW-005	4
3.6	M6 x 1.0 x 12 Socket Head Cap Screw	RT-PSW-006	4
3.7	Leg Mounting Bracket	RT-PSW-007	1
3.8	M5 x 0.8 x 30 Pan Head Phillips Screw	RT-PSW-008	1
3.9	M5 Lock Washer	RT-PSW-009	2
3.10	M5 x 12 x 1 Washer	RT-PSW-010	2
3.11	Handle Mounting Bracket	RT-PSW-011	1
3.12	M5 x 0.8 x 8 Pan Head Phillips Screw	RT-PSW-012	1
3.13	M8 x 1.25 x 45 Hex Head Bolt	RT-PSW-013	4
3.14	M8 x 19 x 2 Washer	RT-PSW-014	8
3.15	M8 Lock Washer	RT-PSW-015	4
3.16	M8 x 1.25 x 12 Hex Nut	RT-PSW-016	4
3.17	M8 x 1.25 x 25 Flat Head Socket Screw	RT-PSW-017	4
3.18	M8 x 19 x 2 Washer	RT-PSW-018	4
3.19	M8 Lock Washer	RT-PSW-019	4
3.20	M8 x 1.25 x 12 Hex Nut	RT-PSW-020	4
3.21	Wing Mounting Hardware Bag (Includes 3.13-3.16)	RT-PSW-021	1
3.22	Rail Mounting Hardware Bag (Includes 3.17-3.20)	RT-PSW-022	1
3.23	Leg Mounting Hardware Bag (Includes 3.2-3.6, 3.7-3.12)	RT-PSW-023	1

Exploded View 4: 32" Fence Assembly for Router Tables (RT-F32)

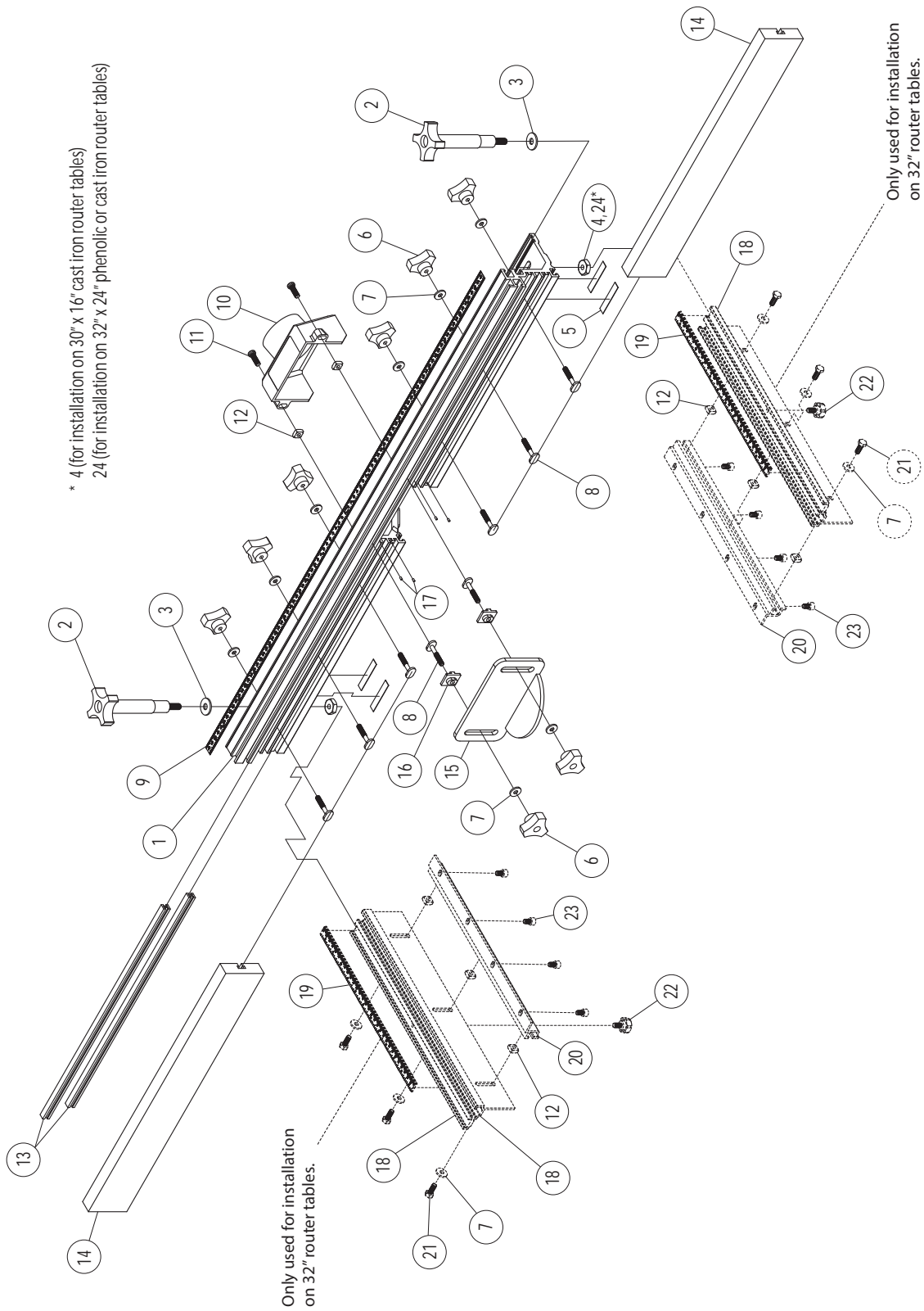

Parts List 4: 32" Fence Assembly for Router Tables (RT-F32)

No.	Description	Part No.	Qty.
N/A	32" Fence Assembly for Router Tables	RT-F32	1
4.1	32" Router Table Fence	RT-F32-001	1
4.2	Fence Lock Knob	RT-F32-002	2
4.3	M8 x 23 x 2 Washer	RT-F32-003	2
4.4	23mm Wide Lock Knob Nut	RT-F32-004	2
4.5	Router Fence Glide Pad	RT-F32-005	4
4.6	Fence Face Plate Lock Knob	RT-F32-006	8
4.7	M6 x 16 x 2 Washer	RT-F32-007	14
4.8	M6 x 1.0 x 35 T-Bolt	RT-F32-008	8
4.9	Fence Ruler	RT-F32-009	1
4.10	2 ½ Inch Dust Port	RT-F32-010	1
4.11	¼"-20 x ¾" Pan Head Phillips Screw	RT-F32-011	2
4.12	¼"-20 Square Nut	RT-F32-012	8
4.13	Face Plate Spacer Bar	RT-F32-013	2
4.14	Face Plate	RT-F32-014	2
4.15	Router Fence Guard	RT-F32-015	1
4.16	Router Fence Guard Spacer	RT-F32-016	2
4.17	Spring Pin (3mm x 10mm)	RT-F32-017	4
4.18	32" Table Rail	RT-F32-018	2
4.19	Rail Ruler	RT-F32-019	2
4.20	Rail Mounting Bracket	RT-F32-020	2
4.21	¼"-20 x 5/8" Hex Head Bolt	RT-F32-021	6
4.22	M6 x 1.0 Lock Knob	RT-F32-022	2
4.23	M6 x 1.0 x 12 Socket Head Cap Screw	RT-F32-023	8
4.24	19mm Wide Lock Knob Nut	RT-F32-024	2

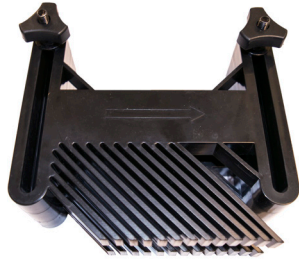

Double Horizontal Feather Board for Router Tables **RT-HFD**

- Holds your workpiece safely against the router fence for added stability
- Stackable featherboards for extra support for taller stock
- Easy-grip lock knobs
- Compatible with all SawStop Router Tables and Fences



Single Vertical Feather Board for Router Tables **RT-VFS**

- Holds your workpiece safely against the router fence for added stability
- Easy-grip lock knobs
- Compatible with all SawStop Router Tables and Fences



9 Piece Brass Precision Template Guide Set **RT-TGS**

- Includes 8 template guides for various routing applications: 1 19/64", 5/8", 27/32", 17/32", 17/64", 9/32", 11/32", 13/32"
- Includes 1 locking nut
- Includes 1 3/8" Insert Ring
- Designed to fit most routers

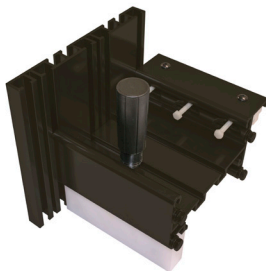

Stock Guide for Router Table Fence **RT-STP**

- Compatible with all SawStop Router Fences
- Provides added safety and stability for moving your material through the router bit



Downdraft Dust Collection Box for Router Lift **RT-DCB**

- Collects below-table dust
- Connects to 4" dust tube
- Compatible with all SawStop Router Tables



Flip Stop for Router Fence **RT-FLS**

- Designed to quickly give you accurate, repeatable measurements
- Compatible with all SawStop Router Fences

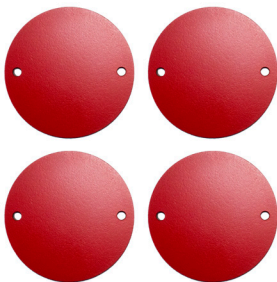

4 Piece Phenolic Zero Clearance Insert Ring Set for Router Lift **RT-PZR**

- Ultra-strong phenolic core material to reduce tear out and chip out

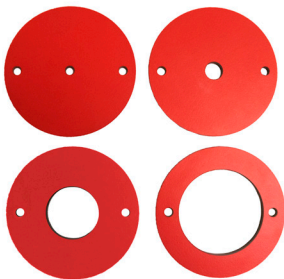

4 Piece Phenolic Insert Ring Set for Router Lift **RT-PIR**

- Ultra-strong phenolic core material to reduce tear out and chip out

This page is intentionally blank.

This page is intentionally blank.

SawStop, LLC
11555 SW Myslony St | Tualatin, Oregon 97062 USA
www.sawstop.com

Main Phone: (503) 570-3200

Service: (503) 582-9934

Fax: (503) 570-3303

Email: info@sawstop.com